

ANGLE HEAD HOLDER CATEGORY

SAG-D ANGLE HEAD HOLDER	S-2
SAU ANGLE HEAD HOLDER [UNIVERSAL TYPE]	S-3
SAR ANGLE HEAD HOLDER	S-4~7
SAC ANGLE HEAD HOLDER	S-8~17
SAM ANGLE HEAD HOLDER	S-18~27
SAG ANGLE HEAD HOLDER [SLIM TYPE]	S-28~32
SAD ANGLE HEAD HOLDER [SLIM TYPE]	S-33
FIXED BLOCK	S-35~36

SAG-D ANGLE HEAD HOLDER

FOR DUAL SIDE MACHINING

SAG-D 雙頭龍銑削頭 [用於雙面加工]

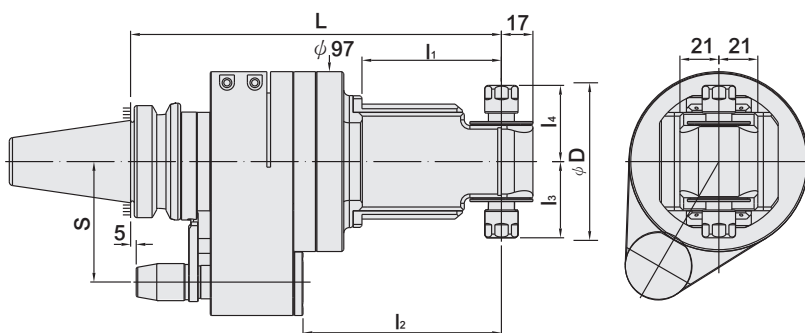

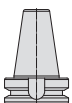
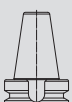
SHANK	MODEL NO.	TYPE	L	l ₁	l ₂	l ₃	l ₄	φ D	S	TORQUE	COLLET	SIZE RANGE	WEIGHT (KGS)
 MAS 403	11.676.11DE.170	BT40 x SAG11DE - 170	170	45.2	77	39.2	39.2	80	65	10N-m	ER11	1 ~ 7	5.10
	11.676.11DE.200	BT40 x SAG11DE - 200	200	75.2	107	39.2	39.2	80	65	10N-m	ER11	1 ~ 7	5.30
	11.676.11DE.230	BT40 x SAG11DE - 230	230	105.2	137	39.2	39.2	80	65	10N-m	ER11	1 ~ 7	5.50
	11.676.11DE.260	BT40 x SAG11DE - 260	260	135.2	167	39.2	39.2	80	65	10N-m	ER11	1 ~ 7	5.70
	11.676.06DS.170	BT40 x SAG06DS - 170	170	45.2	77	42	42	85	65	10N-m	SKS6	3 ~ 6	5.10
	11.676.06DS.200	BT40 x SAG06DS - 200	200	75.2	107	42	42	85	65	10N-m	SKS6	3 ~ 6	5.30
	11.676.06DS.230	BT40 x SAG06DS - 230	230	105.2	137	42	42	85	65	10N-m	SKS6	3 ~ 6	5.50
 DaulDRIVE+	11.676.06DS.260	BT40 x SAG06DS - 260	260	135.2	167	42	42	85	65	10N-m	SKS6	3 ~ 6	5.70
	26.676.11DE.170	SBT40 x SAG11DE - 170	170	45.2	77	39.2	39.2	80	65	10N-m	ER11	1 ~ 7	5.10
	26.676.11DE.200	SBT40 x SAG11DE - 200	200	75.2	107	39.2	39.2	80	65	10N-m	ER11	1 ~ 7	5.30
	26.676.11DE.230	SBT40 x SAG11DE - 230	230	105.2	137	39.2	39.2	80	65	10N-m	ER11	1 ~ 7	5.50
	26.676.11DE.260	SBT40 x SAG11DE - 260	260	135.2	167	39.2	39.2	80	65	10N-m	ER11	1 ~ 7	5.70
	26.676.06DS.170	SBT40 x SAG06DS - 170	170	45.2	77	42	42	85	65	10N-m	SKS6	3 ~ 6	5.10
	26.676.06DS.200	SBT40 x SAG06DS - 200	200	75.2	107	42	42	85	65	10N-m	SKS6	3 ~ 6	5.30
26.676.06DS.230	SBT40 x SAG06DS - 230	230	105.2	137	42	42	85	65	10N-m	SKS6	3 ~ 6	5.50	
26.676.06DS.260	SBT40 x SAG06DS - 260	260	135.2	167	42	42	85	65	10N-m	SKS6	3 ~ 6	5.70	

Feature:

- ▶ SAG-D has two output tool shafts and can achieve machining at 180 degree opposite directions.
- ▶ Reduce tool changing frequency and increase machining efficiency.
- ▶ Save your money buying another angle head for different direction of lateral machining.
- ▶ Conserve the space of tool magazine.

Product information:

- ▶ Gear ratio 1:1.
- ▶ Max. revolution: 6000rpm.
- ▶ Max. torque: 15 N-m.
- ▶ Suggested $A_p \leq 2\text{mm}$.
- ▶ Coolant feed through dowel pin, coolant outlet from 2 coolant holes.
- ▶ Max. water pressure: 7kgf/cm^2 (100PSI).
- ▶ Two outputs rotate in different directions.
- ▶ Can be used for ATC.

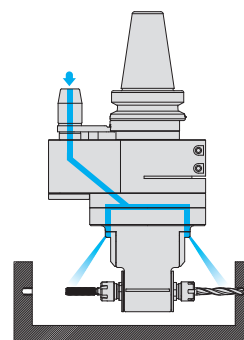
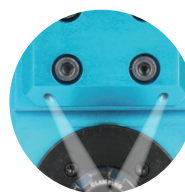

Optional
Fixed Block



P.S-35~36



Reminder:

- ▶ Fix blocks are necessary for installing angle head on the machine [P.S-35~36].
- ▶ Fix blocks are varied by different machine designs. Please confirm the detailed dimensions when ordering.

SAU ANGLE HEAD HOLDER

UNIVERSAL TYPE FOR MEDIUM CUTTING

SAU 萬向銑削頭

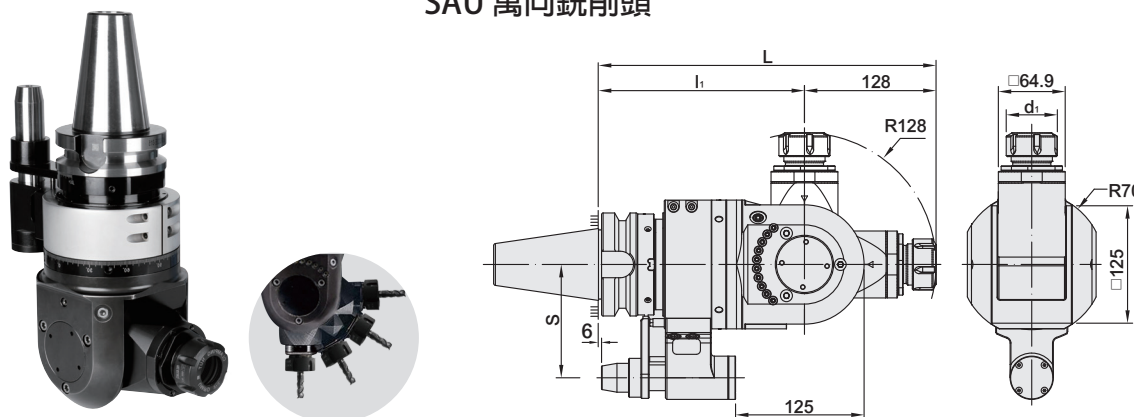

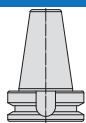
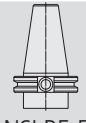
SHANK	MODEL NO.	TYPE	L	li	S	TORQUE	COLLET	SIZE RANGE	WEIGHT (KGS)
 MAS 403	12.789.32.328	BT50 x SAU32E - 328	328	200	110	40 N-m	ER32	2 ~ 20	20.9
INCHES									
 ANSI B5.50	32.789.32.131	CAT50 x SAU32E - 13.1"	13.1	7.87	4.33	40 N-m	ER32	2 ~ 20	21.5

Product information:

- ▶ Gear ratio 1:1.
- ▶ Max. revolution: 4000rpm.
- ▶ Max. torque: 40N-m.
- ▶ Suggested $A_p \leq 4$ mm.
- ▶ Adjustable spindle angle from 0° to 90° on inclined surfaces.
- ▶ Adjustable angle increment: 1°.
- ▶ Coolant feed through dowel pin, coolant outlet from coolant holes.
- ▶ Rotating direction opposite to machine spindle.
- ▶ Can be used for ATC.



Reminder:

- ▶ Fix blocks are necessary for installing angle head on the machine [P.5-35~36].
- ▶ Fix blocks are varied by different machine designs. Please confirm the detailed dimensions when ordering.

Optional
Fixed Block



P.5-35~36



SAR ANGLE HEAD HOLDER

FOR HEAVY-DUTY CUTTING

SAR 大鋼炮銑削頭

(SBT TYPE)

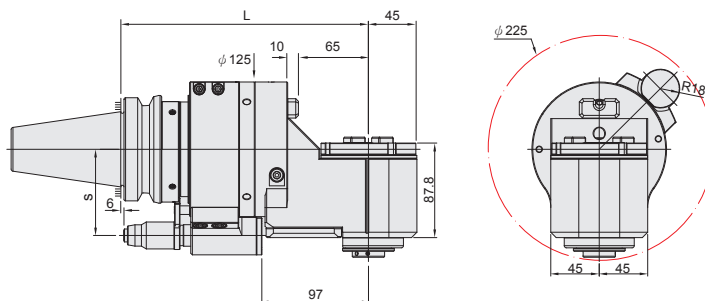

T W PAT NO. M420384
C N PAT NO. ZL201120430504.9

SHANK	MODEL NO.	TYPE	L	S	TORQUE	WEIGHT (KGS)
 MAS 403	12.643	BT50 x SAR50 / SBT30 - 230	230	80	50 N-m	16.1
	12.643S	BT50 x SAR50 / SBT30 - 230S	230	110	50 N-m	16.1
 DaulDRIVE+	27.643	SBT50 x SAR50 / SBT30 - 230	230	80	50 N-m	16.1
	27.643S	SBT50 x SAR50 / SBT30 - 230S	230	110	50 N-m	16.1
 ANSI B5.50	32.643	CAT50 x SAR50 / SBT30 - 230	234.95	80	50 N-m	16.1
	32.643S	CAT50 x SAR50 / SBT30 - 230S	234.95	110	50 N-m	16.1
 DaulDRIVE+	44.643	SCAT50 x SAR50 / SBT30 - 230	234.95	80	50 N-m	16.1
	44.643S	SCAT50 x SAR50 / SBT30 - 230S	234.95	110	50 N-m	16.1
 DIN 69871-A	52.643	DAT50 x SAR50 / SBT30 - 230	235	80	50 N-m	16.1
	52.643S	DAT50 x SAR50 / SBT30 - 230S	235	110	50 N-m	16.1
 DaulDRIVE+	67.643	SDAT50 x SAR50 / SBT30 - 230	235	80	50 N-m	16.1
	67.643S	SDAT50 x SAR50 / SBT30 - 230S	235	110	50 N-m	16.1

Product information:

- ▶ Gear ratio 1:1.
- ▶ Max. revolution: 3000rpm.
- ▶ Max. torque: 50N-m.
- ▶ Suggested $A_p \leq 4\text{mm}$.
- ▶ Coolant feed through dowel pin, coolant outlet from a coolant nozzle.
- ▶ Max. water pressure: $7\text{kgf/cm}^2(100\text{PSI})$.
- ▶ Rotating direction same as machine spindle.
- ▶ Can be used for ATC.



Reminder:

- ▶ Fix blocks are necessary for installing angle head on the machine [P.5-35~36].
- ▶ Fix blocks are varied by different machine designs. Please confirm the detailed dimensions when ordering.

Optional
Fixed Block



P.5-35~36







SAR ANGLE HEAD HOLDER

FOR HEAVY-DUTY CUTTING

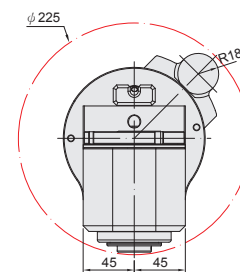
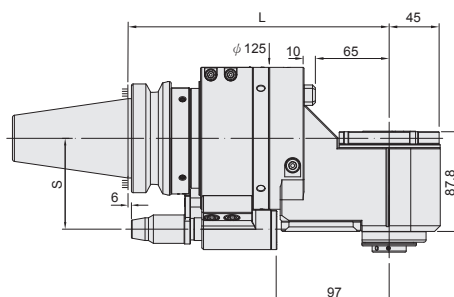
SAR 大鋼炮銑削頭

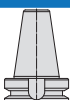
(PSC TYPE)

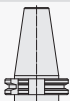
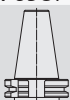

SHANK	MODEL NO.	TYPE	L	S	TORQUE	WEIGHT (KGS)
 MAS 403	12.646.C50.230	BT50 x SAR50 / PSC50 - 230	230	80	50 N-m	16.1
	12.646S.C50.230	BT50 x SAR50 / PSC50 - 230S	230	110	50 N-m	16.1
 DaulDRIVE+	27.646.C50.230	SBT50 x SAR50 / PSC50 - 230	230	80	50 N-m	16.1
	27.646S.C50.230	SBT50 x SAR50 / PSC50 - 230S	230	110	50 N-m	16.1
 ANSI B5.50	32.646.C50.230	CAT50 x SAR50 / PSC50 - 230	234.95	80	50 N-m	16.1
	32.646S.C50.230	CAT50 x SAR50 / PSC50 - 230S	234.95	110	50 N-m	16.1
 DaulDRIVE+	44.646.C50.230	SCAT50 x SAR50 / PSC50 - 230	234.95	80	50 N-m	16.1
	44.646S.C50.230	SCAT50 x SAR50 / PSC50 - 230S	234.95	110	50 N-m	16.1
 DIN 69871-A	52.646.C50.230	DAT50 x SAR50 / PSC50 - 230	235	80	50 N-m	16.1
	52.646S.C50.230	DAT50 x SAR50 / PSC50 - 230S	235	110	50 N-m	16.1
 DaulDRIVE+	67.646.C50.230	SDAT50 x SAR50 / PSC50 - 230	235	80	50 N-m	16.1
	67.646S.C50.230	SDAT50 x SAR50 / PSC50 - 230S	235	110	50 N-m	16.1

Product information:

- ▶ Gear ratio 1:1.
- ▶ Max. revolution: 3000rpm.
- ▶ Max. torque: 50N-m.
- ▶ Suggested $A_p \leq 4\text{mm}$.
- ▶ Coolant feed through dowel pin, coolant outlet from a coolant nozzle.
- ▶ Max. water pressure: 7kgf/cm^2 (100PSI).
- ▶ Rotating direction same as machine spindle.
- ▶ Can be used for ATC.



Reminder:

- ▶ Fix blocks are necessary for installing angle head on the machine [P.S-35~36].
- ▶ Fix blocks are varied by different machine designs. Please confirm the detailed dimensions when ordering.

Optional
Fixed Block



P.S-35~36



SAR ANGLE HEAD HOLDER

FOR HEAVY-DUTY CUTTING

SAR 大鋼炮銑削頭

[MLD TYPE]

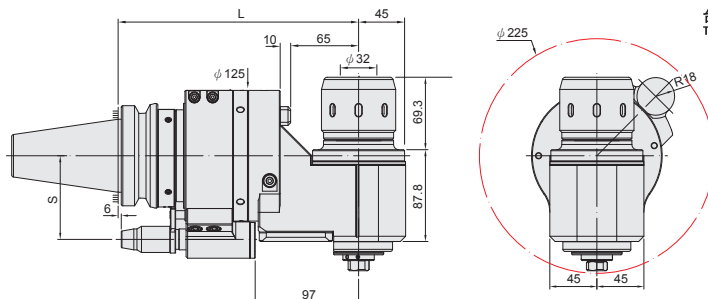

SHANK	MODEL NO.	TYPE	L	S	TORQUE	WEIGHT (KGS)
 MAS 403	12.645.32.230	BT50 x SAR50 / MLD32 - 230	230	80	50 N-m	16.1
	12.645S.32.230	BT50 x SAR50 / MLD32 - 230S	230	110	50 N-m	16.1
 DaulDRIVE+	27.645.32.230	SBT50 x SAR50 / MLD32 - 230	230	80	50 N-m	16.1
	27.645S.32.230	SBT50 x SAR50 / MLD32 - 230S	230	110	50 N-m	16.1
 ANSI B5.50	32.645.32.230	CAT50 x SAR50 / MLD32 - 230	234.95	80	50 N-m	16.1
	32.645S.32.230	CAT50 x SAR50 / MLD32 - 230S	234.95	110	50 N-m	16.1
 DaulDRIVE+	44.645.32.230	SCAT50 x SAR50 / MLD32 - 230	234.95	80	50 N-m	16.1
	44.645S.32.230	SCAT50 x SAR50 / MLD32 - 230S	234.95	110	50 N-m	16.1
 DIN 69871-A	52.645.32.230	DAT50 x SAR50 / MLD32 - 230	235	80	50 N-m	16.1
	52.645S.32.230	DAT50 x SAR50 / MLD32 - 230S	235	110	50 N-m	16.1
 DaulDRIVE+	67.645.32.230	SDAT50 x SAR50 / MLD32 - 230	235	80	50 N-m	16.1
	67.645S.32.230	SDAT50 x SAR50 / MLD32 - 230S	235	110	50 N-m	16.1

Product information:

- ▶ Gear ratio 1:1.
- ▶ Max. revolution: 3000rpm.
- ▶ Max. torque: 50N-m.
- ▶ Suggested $A_p \leq 4\text{mm}$.
- ▶ Coolant feed through dowel pin, coolant outlet from a coolant nozzle.
- ▶ Max. water pressure: 7kgf/cm^2 (100PSI).
- ▶ Rotating direction same as machine spindle.
- ▶ Can be used for ATC.



Reminder:

- ▶ Fix blocks are necessary for installing angle head on the machine [P.5-35~36].
- ▶ Fix blocks are varied by different machine designs. Please confirm the detailed dimensions when ordering.

Optional
Fixed Block



P.5-35~36



SAR ANGLE HEAD HOLDER

FOR HEAVY-DUTY CUTTING

SAR 大鋼炮銑削頭

[FMA TYPE]

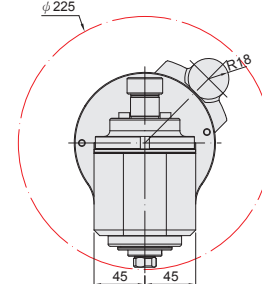
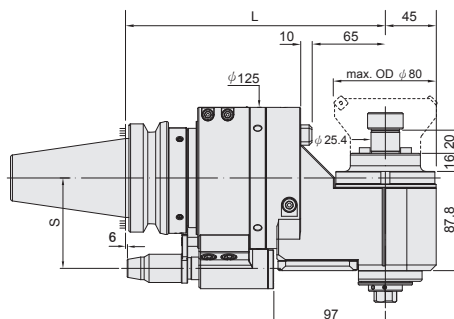

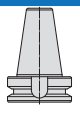
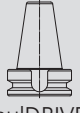
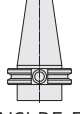
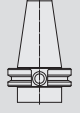
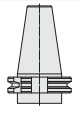
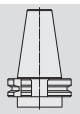
SHANK	MODEL NO.	TYPE	L	S	TORQUE	WEIGHT (KGS)
 MAS 403	12.644.68.230	BT50 x SAR50 / FMA25.4 - 230	230	80	50 N-m	16.1
	12.644S.68.230	BT50 x SAR50 / FMA25.4 - 230S	230	110	50 N-m	16.1
 DauIDRIVE+	27.644.68.230	SBT50 x SAR50 / FMA25.4 - 230	230	80	50 N-m	16.1
	27.644S.68.230	SBT50 x SAR50 / FMA25.4 - 230S	230	110	50 N-m	16.1
 ANSI B5.50	32.644.68.230	CAT50 x SAR50 / FMA25.4 - 230	234.95	80	50 N-m	16.1
	32.644S.68.230	CAT50 x SAR50 / FMA25.4 - 230S	234.95	110	50 N-m	16.1
 DauIDRIVE+	44.644.68.230	SCAT50 x SAR50 / FMA25.4 - 230	234.95	80	50 N-m	16.1
	44.644S.68.230	SCAT50 x SAR50 / FMA25.4 - 230S	234.95	110	50 N-m	16.1
 DIN 69871-A	52.644.68.230	DAT50 x SAR50 / FMA25.4 - 230	235	80	50 N-m	16.1
	52.644S.68.230	DAT50 x SAR50 / FMA25.4 - 230S	235	110	50 N-m	16.1
 DauIDRIVE+	67.644.68.230	SDAT50 x SAR50 / FMA25.4 - 230	235	80	50 N-m	16.1
	67.644S.68.230	SDAT50 x SAR50 / FMA25.4 - 230S	235	110	50 N-m	16.1

Product information:

- ▶ Gear ratio 1:1.
- ▶ Max. revolution: 3000rpm.
- ▶ Max. torque: 50N-m.
- ▶ Suggested $A_p \leq 4\text{mm}$.
- ▶ Coolant feed through dowel pin, coolant outlet from a coolant nozzle.
- ▶ Max. water pressure: 7kgf/cm^2 (100PSI).
- ▶ Rotating direction same as machine spindle.
- ▶ Can be used for ATC.



Reminder:

- ▶ Fix blocks are necessary for installing angle head on the machine [P.5-35~36].
- ▶ Fix blocks are varied by different machine designs. Please confirm the detailed dimensions when ordering.

Optional
Fixed Block



P.5-35~36



SAC ANGLE HEAD HOLDER

FOR MEDIUM CUTTING

SAC 中鋼炮銑削頭

(SKS TYPE)

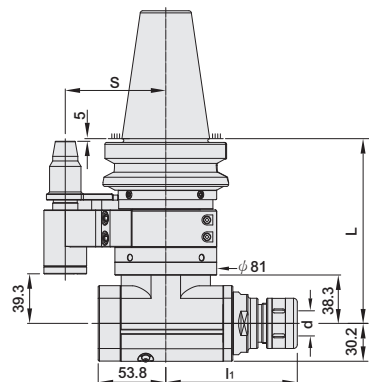

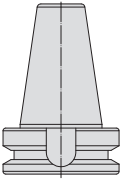
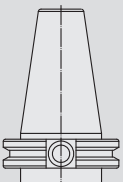
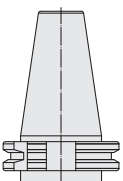
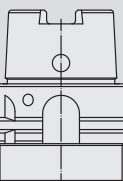
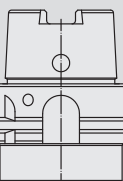
SHANK	MODEL NO.	TYPE	L	l ₁	S	TORQUE	COLLET	SIZE RANGE ^d	WEIGHT (KGS)
 MAS 403	11.639.10.130	BT40 x SAC10S - 130	130	88	65	25 N-m	SKS10	3 ~ 10	6.40
	11.639.13.130	BT40 x SAC13S - 130	130	89.6	65	25 N-m	SKS13	3 ~ 13	6.40
	11.639.16.130	BT40 x SAC16S - 130	130	102.3	65	25 N-m	SKS16	3 ~ 16	6.40
	11.639.20.130	BT40 x SAC20S - 130	130	110.3	65	25 N-m	SKS20	3 ~ 20	6.40
	12.639.10.147	BT50 x SAC10S - 147	147	88	80	25 N-m	SKS10	3 ~ 10	8.40
	12.639.13.147	BT50 x SAC13S - 147	147	89.6	80	25 N-m	SKS13	3 ~ 13	8.40
	12.639.16.147	BT50 x SAC16S - 147	147	102.3	80	25 N-m	SKS16	3 ~ 16	8.40
 ANSI B5.50	12.639.20.147	BT50 x SAC20S - 147	147	110.3	80	25 N-m	SKS20	3 ~ 20	8.40
	31.639.10.150	CAT40 x SAC10S - 150	150	88	65	25 N-m	SKS10	3 ~ 10	6.40
	31.639.13.150	CAT40 x SAC13S - 150	150	89.6	65	25 N-m	SKS13	3 ~ 13	6.40
	31.639.16.150	CAT40 x SAC16S - 150	150	102.3	65	25 N-m	SKS16	3 ~ 16	6.40
	31.639.20.150	CAT40 x SAC20S - 150	150	110.3	65	25 N-m	SKS20	3 ~ 20	6.40
	32.639.10.150	CAT50 x SAC10S - 150	150	88	80	25 N-m	SKS10	3 ~ 10	8.40
	32.639.13.150	CAT50 x SAC13S - 150	150	89.6	80	25 N-m	SKS13	3 ~ 13	8.40
 DIN 69871-A	32.639.16.150	CAT50 x SAC16S - 150	150	102.3	80	25 N-m	SKS16	3 ~ 16	8.40
	32.639.20.150	CAT50 x SAC20S - 150	150	110.3	80	25 N-m	SKS20	3 ~ 20	8.40
	51.639.10.146	DAT40 x SAC10S - 146	146	88	65	25 N-m	SKS10	3 ~ 10	6.40
	51.639.13.146	DAT40 x SAC13S - 146	146	89.6	65	25 N-m	SKS13	3 ~ 13	6.40
	51.639.16.146	DAT40 x SAC16S - 146	146	102.3	65	25 N-m	SKS16	3 ~ 16	6.40
	51.639.20.146	DAT40 x SAC20S - 146	146	110.3	65	25 N-m	SKS20	3 ~ 20	6.40
	52.639.10.150	DAT50 x SAC10S - 150	150	88	80	25 N-m	SKS10	3 ~ 10	8.40
 DIN 69893 A	52.639.13.150	DAT50 x SAC13S - 150	150	89.6	80	25 N-m	SKS13	3 ~ 13	8.40
	52.639.16.150	DAT50 x SAC16S - 150	150	102.3	80	25 N-m	SKS16	3 ~ 16	8.40
	52.639.20.150	DAT50 x SAC20S - 150	150	110.3	80	25 N-m	SKS20	3 ~ 20	8.40
	73.639.10.155	HSK63A x SAC10S - 155	155	88	65	25 N-m	SKS10	3 ~ 10	6.40
	73.639.13.155	HSK63A x SAC13S - 155	155	89.6	65	25 N-m	SKS13	3 ~ 13	6.40
	73.639.16.155	HSK63A x SAC16S - 155	155	102.3	65	25 N-m	SKS16	3 ~ 16	6.40
	73.639.20.155	HSK63A x SAC20S - 155	155	110.3	65	25 N-m	SKS20	3 ~ 20	6.40
 DIN 69893 A	75.639.10.151	HSK100A x SAC10S - 151	151	88	80	25 N-m	SKS10	3 ~ 10	8.40
	75.639.13.151	HSK100A x SAC13S - 151	151	89.6	80	25 N-m	SKS13	3 ~ 13	8.40
	75.639.16.151	HSK100A x SAC16S - 151	151	102.3	80	25 N-m	SKS16	3 ~ 16	8.40
	75.639.20.151	HSK100A x SAC20S - 151	151	110.3	80	25 N-m	SKS20	3 ~ 20	8.40

Product information:

- ▶ Gear ratio 1:1. ▶ Max. revolution: 3000rpm. ▶ Max. torque: 25N-m. ▶ Suggested Ap ≤ 3mm.
- ▶ Internal coolant not available. ▶ Rotating direction opposite to machine spindle. ▶ Can be used for ATC.



Reminder:

- ▶ Fix blocks are necessary for installing angle head on the machine [P.5-35~36].
- ▶ Fix blocks are varied by different machine designs. Please confirm the detailed dimensions when ordering.

Optional
Fixed Block



P.5-35~36



SAC ANGLE HEAD HOLDER

FOR MEDIUM CUTTING

SAC 中鋼炮銑削頭

(SKS TYPE)

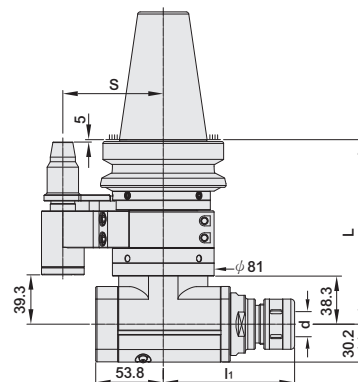

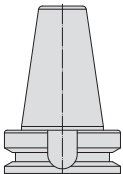
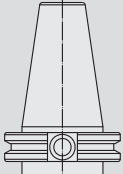
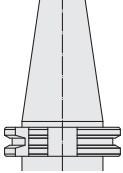
SHANK	MODEL NO.	TYPE	L	l ₁	S	TORQUE	COLLET	SIZE RANGE	WEIGHT (KGS)
 DualDRIVE+	26.639.10.130	SBT40 x SAC10S - 130	130	89.6	65	25 N-m	SKS10	3 ~ 10	6.40
	26.639.13.130	SBT40 x SAC13S - 130	130	91	65	25 N-m	SKS13	3 ~ 13	6.40
	26.639.16.130	SBT40 x SAC16S - 130	130	92	65	25 N-m	SKS16	3 ~ 16	6.40
	26.639.20.130	SBT40 x SAC20S - 130	130	96	65	25 N-m	SKS20	3 ~ 20	6.40
	27.639.10.147	SBT50 x SAC10S - 147	147	89.6	80	25 N-m	SKS10	3 ~ 10	8.40
	27.639.13.147	SBT50 x SAC13S - 147	147	91	80	25 N-m	SKS13	3 ~ 13	8.40
	27.639.16.147	SBT50 x SAC16S - 147	147	92	80	25 N-m	SKS16	3 ~ 16	8.40
 DualDRIVE+	27.639.20.147	SBT50 x SAC20S - 147	147	96	80	25 N-m	SKS20	3 ~ 20	8.40
	43.639.10.150	SCAT40 x SAC10S - 150	150	88	65	25 N-m	SKS10	3 ~ 10	6.40
	43.639.13.150	SCAT40 x SAC13S - 150	150	89.6	65	25 N-m	SKS13	3 ~ 13	6.40
	43.639.16.150	SCAT40 x SAC16S - 150	150	102.3	65	25 N-m	SKS16	3 ~ 16	6.40
	43.639.20.150	SCAT40 x SAC20S - 150	150	110.3	65	25 N-m	SKS20	3 ~ 20	6.40
	44.639.10.150	SCAT50 x SAC10S - 150	150	88	80	25 N-m	SKS10	3 ~ 10	8.40
	44.639.13.150	SCAT50 x SAC13S - 150	150	89.6	80	25 N-m	SKS13	3 ~ 13	8.40
 DualDRIVE+	44.639.16.150	SCAT50 x SAC16S - 150	150	102.3	80	25 N-m	SKS16	3 ~ 16	8.40
	44.639.20.150	SCAT50 x SAC20S - 150	150	110.3	80	25 N-m	SKS20	3 ~ 20	8.40
	66.639.10.146	SDAT40 x SAC10S - 146	146	88	65	25 N-m	SKS10	3 ~ 10	6.40
	66.639.13.146	SDAT40 x SAC13S - 146	146	89.6	65	25 N-m	SKS13	3 ~ 13	6.40
	66.639.16.146	SDAT40 x SAC16S - 146	146	102.3	65	25 N-m	SKS16	3 ~ 16	6.40
	66.639.20.146	SDAT40 x SAC20S - 146	146	110.3	65	25 N-m	SKS20	3 ~ 20	6.40
	67.639.10.150	SDAT50 x SAC10S - 150	150	88	80	25 N-m	SKS10	3 ~ 10	8.40
	67.639.13.150	SDAT50 x SAC13S - 150	150	89.6	80	25 N-m	SKS13	3 ~ 13	8.40
	67.639.16.150	SDAT50 x SAC16S - 150	150	102.3	80	25 N-m	SKS16	3 ~ 16	8.40
67.639.20.150	SDAT50 x SAC20S - 150	150	110.3	80	25 N-m	SKS20	3 ~ 20	8.40	

Product information:

- ▶ Gear ratio 1:1.
- ▶ Max. revolution: 3000rpm.
- ▶ Max. torque: 25N-m.
- ▶ Suggested Ap ≤ 3mm.
- ▶ Internal coolant not available.
- ▶ Rotating direction opposite to machine spindle.
- ▶ Can be used for ATC.



Reminder:

- ▶ Fix blocks are necessary for installing angle head on the machine [P.5-35~36].
- ▶ Fix blocks are varied by different machine designs. Please confirm the detailed dimensions when ordering.

Optional
Fixed Block



P.5-35~36



SAC ANGLE HEAD HOLDER

FOR MEDIUM CUTTING

SAC 中鋼炮銑削頭

(ER TYPE)

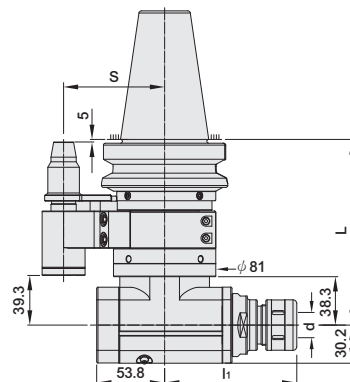

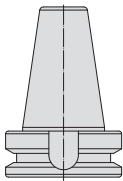
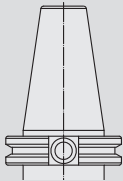
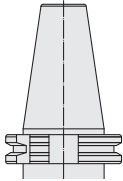
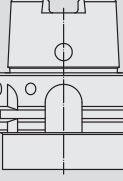
SHANK	MODEL NO.	TYPE	L	l ₁	S	TORQUE	COLLET	SIZE RANGE	WEIGHT (KGS)
 <p>MAS 403</p>	11.640.16.130	BT40 x SAC16E - 130	130	89.6	65	25 N-m	ER16	1 ~ 10	6.40
	11.640.20.130	BT40 x SAC20E - 130	130	91	65	25 N-m	ER20	1 ~ 13	6.40
	11.640.25.130	BT40 x SAC25E - 130	130	92	65	25 N-m	ER25	1 ~ 16	6.40
	11.640.32.130	BT40 x SAC32E - 130	130	96	65	25 N-m	ER32	2 ~ 20	6.44
	12.640.16.147	BT50 x SAC16E - 147	147	89.6	80	25 N-m	ER16	1 ~ 10	8.40
	12.640.20.147	BT50 x SAC20E - 147	147	91	80	25 N-m	ER13	1 ~ 13	8.40
	12.640.25.147	BT50 x SAC25E - 147	147	92	80	25 N-m	ER25	1 ~ 16	8.40
	12.640.32.147	BT50 x SAC32E - 147	147	96	80	25 N-m	ER32	2 ~ 20	8.44
 <p>ANSI B5.50</p>	31.640.16.150	CAT40 x SAC16E - 150	150	89.6	65	25 N-m	ER16	1 ~ 10	6.40
	31.640.20.150	CAT40 x SAC20E - 150	150	91	65	25 N-m	ER20	1 ~ 13	6.40
	31.640.25.150	CAT40 x SAC25E - 150	150	92	65	25 N-m	ER25	1 ~ 16	6.40
	31.640.32.150	CAT40 x SAC32E - 150	150	96	65	25 N-m	ER32	2 ~ 20	6.40
	32.640.16.150	CAT50 x SAC16E - 150	150	89.6	80	25 N-m	ER16	1 ~ 10	8.40
	32.640.20.150	CAT50 x SAC20E - 150	150	91	80	25 N-m	ER13	1 ~ 13	8.40
	32.640.25.150	CAT50 x SAC25E - 150	150	92	80	25 N-m	ER25	1 ~ 16	8.40
	32.640.32.150	CAT50 x SAC32E - 150	150	96	80	25 N-m	ER32	2 ~ 20	8.44
 <p>DIN 69871-A</p>	51.640.16.146	DAT40 x SAC16E - 146	146	89.6	65	25 N-m	ER16	1 ~ 10	6.40
	51.640.20.146	DAT40 x SAC20E - 146	146	91	65	25 N-m	ER20	1 ~ 13	6.40
	51.640.25.146	DAT40 x SAC25E - 146	146	92	65	25 N-m	ER25	1 ~ 16	6.40
	51.640.32.146	DAT40 x SAC32E - 146	146	96	65	25 N-m	ER32	2 ~ 20	6.40
	52.640.16.150	DAT50 x SAC16E - 150	150	89.6	80	25 N-m	ER16	1 ~ 10	8.40
	52.640.20.150	DAT50 x SAC20E - 150	150	91	80	25 N-m	ER20	1 ~ 13	8.40
	52.640.25.150	DAT50 x SAC25E - 150	150	92	80	25 N-m	ER25	1 ~ 16	8.40
	52.640.32.150	DAT50 x SAC32E - 150	150	96	80	25 N-m	ER32	2 ~ 20	8.44
 <p>DIN 69893 A</p>	73.640.16.155	HSK63A x SAC16E - 155	155	89.6	65	25 N-m	ER16	1 ~ 10	6.40
	73.640.20.155	HSK63A x SAC20E - 155	155	91	65	25 N-m	ER20	1 ~ 13	6.40
	73.640.25.155	HSK63A x SAC25E - 155	155	92	65	25 N-m	ER25	1 ~ 16	6.40
	73.640.32.155	HSK63A x SAC32E - 155	155	96	65	25 N-m	ER32	2 ~ 20	6.44
	75.640.16.151	HSK100A x SAC16E - 151	151	89.6	80	25 N-m	ER16	1 ~ 10	8.40
	75.640.20.151	HSK100A x SAC20E - 151	151	91	80	25 N-m	ER13	1 ~ 13	8.40
	75.640.25.151	HSK100A x SAC25E - 151	151	92	80	25 N-m	ER25	1 ~ 16	8.40
	75.640.32.151	HSK100A x SAC32E - 151	151	96	80	25 N-m	ER32	2 ~ 20	8.44

Product information:

- ▶ Gear ratio 1:1. ▶ Max. revolution: 3000rpm. ▶ Max. torque: 25N-m. ▶ Suggested Ap ≤ 3mm.
- ▶ Internal coolant not available. ▶ Rotating direction opposite to machine spindle. ▶ Can be used for ATC.



Reminder:

- ▶ Fix blocks are necessary for installing angle head on the machine [P.5-35~36].
- ▶ Fix blocks are varied by different machine designs. Please confirm the detailed dimensions when ordering.

Optional
Fixed Block



P.5-35~36



SAC ANGLE HEAD HOLDER

FOR MEDIUM CUTTING

SAC 中鋼炮銑削頭

[ER TYPE]

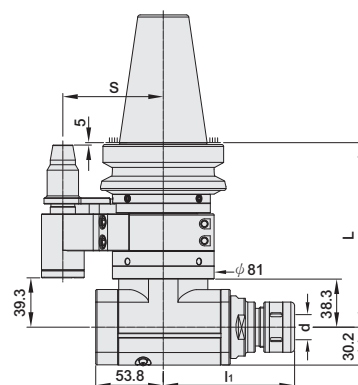

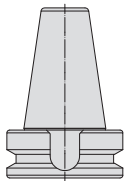
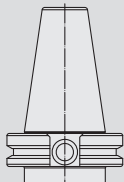
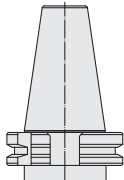
SHANK	MODEL NO.	TYPE	L	l ₁	S	TORQUE	COLLET	SIZE RANGE	WEIGHT (KGS)
 DualDRIVE+	26.640.16.130	SBT40 x SAC16E - 130	130	89.6	65	25 N-m	ER16	1 ~ 10	6.40
	26.640.20.130	SBT40 x SAC20E - 130	130	91	65	25 N-m	ER20	1 ~ 13	6.40
	26.640.25.130	SBT40 x SAC25E - 130	130	92	65	25 N-m	ER25	1 ~ 16	6.40
	26.640.32.130	SBT40 x SAC32E - 130	130	96	65	25 N-m	ER32	2 ~ 20	6.44
	27.640.16.147	SBT50 x SAC16E - 147	147	89.6	80	25 N-m	ER16	1 ~ 10	8.40
 DualDRIVE+	27.640.20.147	SBT50 x SAC20E - 147	147	91	80	25 N-m	ER13	1 ~ 13	8.40
	27.640.25.147	SBT50 x SAC25E - 147	147	92	80	25 N-m	ER25	1 ~ 16	8.40
	27.640.32.147	SBT50 x SAC32E - 147	147	96	80	25 N-m	ER32	2 ~ 20	6.44
	43.640.16.150	SCAT40 x SAC16E - 150	150	89.6	65	25 N-m	ER16	1 ~ 10	6.40
	43.640.20.150	SCAT40 x SAC20E - 150	150	91	65	25 N-m	ER20	1 ~ 13	6.40
 DualDRIVE+	43.640.25.150	SCAT40 x SAC25E - 150	150	92	65	25 N-m	ER25	1 ~ 16	6.40
	43.640.32.150	SCAT40 x SAC32E - 150	150	96	65	25 N-m	ER32	2 ~ 20	6.44
	44.640.16.150	SCAT50 x SAC16E - 150	150	89.6	80	25 N-m	ER16	1 ~ 10	8.40
	44.640.20.150	SCAT50 x SAC20E - 150	150	91	80	25 N-m	ER13	1 ~ 13	8.40
	44.640.25.150	SCAT50 x SAC25E - 150	150	92	80	25 N-m	ER25	1 ~ 16	8.40
	44.640.32.150	SCAT50 x SAC32E - 150	150	96	80	25 N-m	ER32	2 ~ 20	8.44
	66.640.16.146	SDAT40 x SAC16E - 146	146	89.6	65	25 N-m	ER16	1 ~ 10	6.40
	66.640.20.146	SDAT40 x SAC20E - 146	146	91	65	25 N-m	ER20	1 ~ 13	6.40
	66.640.25.146	SDAT40 x SAC25E - 146	146	92	65	25 N-m	ER25	1 ~ 16	6.40
	66.640.32.146	SDAT40 x SAC32E - 146	146	96	65	25 N-m	ER32	2 ~ 20	6.44
	67.640.16.150	SDAT50 x SAC16E - 150	150	89.6	80	25 N-m	ER16	1 ~ 10	8.40
	67.640.20.150	SDAT50 x SAC20E - 150	150	91	80	25 N-m	ER20	1 ~ 13	8.40
	67.640.25.150	SDAT50 x SAC25E - 150	150	92	80	25 N-m	ER25	1 ~ 16	8.40
	67.640.32.150	SDAT50 x SAC32E - 150	150	96	80	25 N-m	ER32	2 ~ 20	8.44

Product information:

- ▶ Gear ratio 1:1.
- ▶ Max. revolution: 3000rpm.
- ▶ Max. torque: 25N-m.
- ▶ Suggested $A_p \leq 3$ mm.
- ▶ Internal coolant not available.
- ▶ Rotating direction opposite to machine spindle.
- ▶ Can be used for ATC.



Reminder:

- ▶ Fix blocks are necessary for installing angle head on the machine [P.5-35~36].
- ▶ Fix blocks are varied by different machine designs. Please confirm the detailed dimensions when ordering.

Optional
Fixed Block



P.5-35~36



SAC ANGLE HEAD HOLDER

FOR MEDIUM CUTTING

SAC 中鋼炮銑削頭

[FMA/B TYPE]

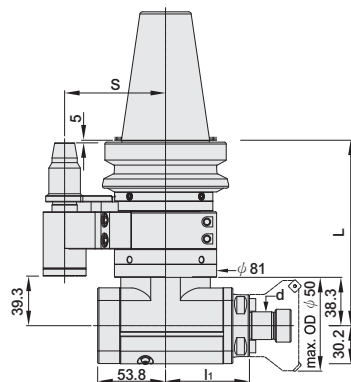

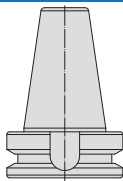
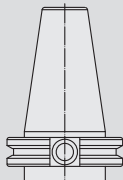
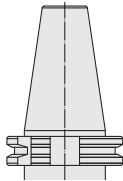
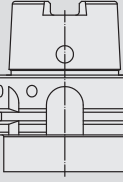
SHANK	MODEL NO.	TYPE	L	d	l ₁	S	TORQUE	WEIGHT (KGS)
 <p>MAS 403</p>	11.641.68.130	BT40 x SAC25.4FA - 130	130	25.4	66	65	25 N-m	6.54
	11.641.22.130	BT40 x SAC22FB - 130	130	22	66	65	25 N-m	6.54
	12.641.68.147	BT50 x SAC25.4FA - 147	147	25.4	66	80	25 N-m	8.54
	12.641.22.147	BT50 x SAC22FB - 147	147	22	66	80	25 N-m	8.54
 <p>ANSI B5.50</p>	31.641.68.150	CAT40 x SAC25.4FA - 150	150	25.4	66	65	25 N-m	6.54
	31.641.22.150	CAT40 x SAC22FB - 150	150	22	66	65	25 N-m	6.54
	32.641.68.150	CAT50 x SAC25.4FA - 150	150	25.4	66	80	25 N-m	8.54
	32.641.22.150	CAT50 x SAC22FB - 150	150	22	66	80	25 N-m	8.54
 <p>DIN 69871-A</p>	51.641.68.146	DAT40 x SAC25.4FA - 146	146	25.4	66	65	25 N-m	6.54
	51.641.22.146	DAT40 x SAC22FB - 146	146	22	66	65	25 N-m	6.54
	52.641.68.150	DAT50 x SAC25.4FA - 150	150	25.4	66	80	25 N-m	8.54
	52.641.22.150	DAT50 x SAC22FB - 150	150	22	66	80	25 N-m	8.54
 <p>DIN 69893 A</p>	73.641.68.155	HSK63A x SAC25.4FA - 155	155	25.4	66	65	25 N-m	6.54
	73.641.22.155	HSK63A x SAC22FB - 155	155	22	66	65	25 N-m	6.54
	75.641.68.151	HSK100A x SAC25.4FA - 151	151	25.4	66	80	25 N-m	8.54
	75.641.22.151	HSK100A x SAC22FB - 151	151	22	66	80	25 N-m	8.54

Product information:

- ▶ Gear ratio 1:1.
- ▶ Max. revolution: 3000rpm.
- ▶ Max. torque: 25N-m.
- ▶ Suggested $A_p \leq 3\text{mm}$.
- ▶ Internal coolant not available.
- ▶ Rotating direction opposite to machine spindle.
- ▶ Can be used for ATC.



Reminder:

- ▶ Fix blocks are necessary for installing angle head on the machine [P.5-35~36].
- ▶ Fix blocks are varied by different machine designs. Please confirm the detailed dimensions when ordering.

Optional
Fixed Block



P.5-35~36



SAC ANGLE HEAD HOLDER

FOR MEDIUM CUTTING

SAC 中鋼炮銑削頭

[FMA/B TYPE]

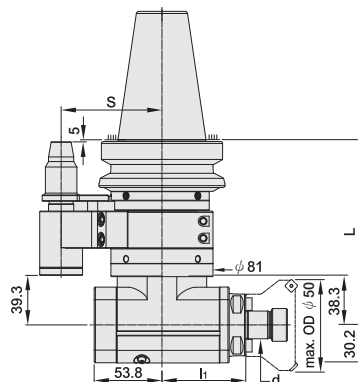

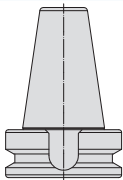
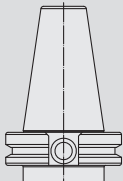
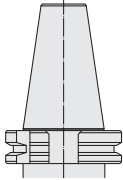
SHANK	MODEL NO.	TYPE	L	d	l ₁	S	TORQUE	WEIGHT (KGS)
 DualDRIVE+	26.641.68.130	SBT40 x SAC25.4FA - 130	130	25.4	66	65	25 N-m	6.54
	26.641.22.130	SBT40 x SAC22FB - 130	130	22	66	65	25 N-m	6.54
	27.641.68.147	SBT50 x SAC25.4FA - 147	147	25.4	66	80	25 N-m	8.54
	27.641.22.147	SBT50 x SAC22FB - 147	147	22	66	80	25 N-m	8.54
 DualDRIVE+	43.641.68.150	SCAT40 x SAC25.4FA - 150	150	25.4	66	65	25 N-m	6.54
	43.641.22.150	SCAT40 x SAC22FB - 150	150	22	66	65	25 N-m	6.54
	44.641.68.150	SCAT50 x SAC25.4FA - 150	150	25.4	66	80	25 N-m	8.54
	44.641.22.150	SCAT50 x SAC22FB - 150	150	22	66	80	25 N-m	8.54
 DualDRIVE+	66.641.68.146	SDAT40 x SAC25.4FA - 146	146	25.4	66	65	25 N-m	6.54
	66.641.22.146	SDAT40 x SAC22FB - 146	146	22	66	65	25 N-m	6.54
	67.641.68.150	SDAT50 x SAC25.4FA - 150	150	25.4	66	80	25 N-m	8.54
	67.641.22.150	SDAT50 x SAC22FB - 150	150	22	66	80	25 N-m	8.54

Product information:

- ▶ Gear ratio 1:1.
- ▶ Max. revolution: 3000rpm.
- ▶ Max. torque: 25N-m.
- ▶ Suggested $A_p \leq 3\text{mm}$.
- ▶ Internal coolant not available.
- ▶ Rotating direction opposite to machine spindle.
- ▶ Can be used for ATC.



Reminder:

- ▶ Fix blocks are necessary for installing angle head on the machine [P.5-35~36].
- ▶ Fix blocks are varied by different machine designs. Please confirm the detailed dimensions when ordering.

Optional
Fixed Block



P.5-35~36



SAC ANGLE HEAD HOLDER

FOR MEDIUM CUTTING

SAC 中鋼炮銑削頭

[PNER TYPE]

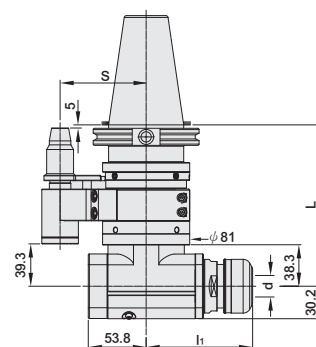

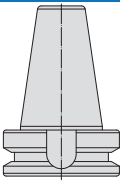
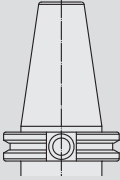
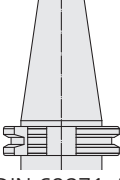
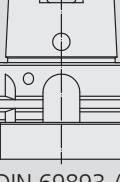
SHANK	MODEL NO.	TYPE	L	l ₁	S	TORQUE	COLLET	SIZE RANGE d	WEIGHT (KGS)
 MAS 403	11.770.20.130	BT40 x SAC20PN - 130	130	91	65	25 N-m	PN20	3 ~ 13	6.40
	11.770.25.130	BT40 x SAC25PN - 130	130	91	65	25 N-m	PN25	3 ~ 16	6.40
	11.770.32.130	BT40 x SAC32PN - 130	130	91.4	65	25 N-m	PN32	3 ~ 20	6.44
	12.770.20.147	BT50 x SAC20PN - 147	147	91	80	25 N-m	PN20	3 ~ 13	6.40
	12.770.25.147	BT50 x SAC25PN - 147	147	91	80	25 N-m	PN25	3 ~ 16	6.40
	12.770.32.147	BT50 x SAC32PN - 147	147	91.4	80	25 N-m	PN32	3 ~ 20	6.44
 ANSI B5.50	31.770.20.150	CAT40 x SAC20PN - 150	150	91	65	25 N-m	PN20	3 ~ 13	6.40
	31.770.25.150	CAT40 x SAC25PN - 150	150	91	65	25 N-m	PN25	3 ~ 16	6.40
	31.770.32.150	CAT40 x SAC32PN - 150	150	91.4	65	25 N-m	PN32	3 ~ 20	6.44
	32.770.20.150	CAT50 x SAC20PN - 150	150	91	80	25 N-m	PN20	3 ~ 13	6.40
	32.770.25.150	CAT50 x SAC25PN - 150	150	91	80	25 N-m	PN25	3 ~ 16	6.40
	32.770.32.150	CAT50 x SAC32PN - 150	150	91.4	80	25 N-m	PN32	3 ~ 20	6.44
 DIN 69871-A	51.770.20.146	DAT40 x SAC20PN - 146	146	91	65	25 N-m	PN20	3 ~ 13	6.40
	51.770.25.146	DAT40 x SAC25PN - 146	146	91	65	25 N-m	PN25	3 ~ 16	6.40
	51.770.32.146	DAT40 x SAC32PN - 146	146	91.4	65	25 N-m	PN32	3 ~ 20	6.44
	52.770.20.150	DAT50 x SAC20PN - 150	150	91	80	25 N-m	PN20	3 ~ 13	6.40
	52.770.25.150	DAT50 x SAC25PN - 150	150	91	80	25 N-m	PN25	3 ~ 16	6.40
	52.770.32.150	DAT50 x SAC32PN - 150	150	91.4	80	25 N-m	PN32	3 ~ 20	6.44
 DIN 69893 A	73.770.20.155	HSK63A x SAC20PN - 155	155	91	65	25 N-m	PN20	3 ~ 13	6.40
	73.770.25.155	HSK63A x SAC25PN - 155	155	91	65	25 N-m	PN25	3 ~ 16	6.40
	73.770.32.155	HSK63A x SAC32PN - 155	155	91.4	65	25 N-m	PN32	3 ~ 20	6.44
	75.770.20.151	HSK100A x SAC20PN - 151	151	91	80	25 N-m	PN20	3 ~ 13	6.40
	75.770.25.151	HSK100A x SAC25PN - 151	151	91	80	25 N-m	PN25	3 ~ 16	6.40
	75.770.32.151	HSK100A x SAC32PN - 151	151	91.4	80	25 N-m	PN32	3 ~ 20	6.44

Product information:

- ▶ Gear ratio 1:1.
- ▶ Max. revolution: 3000rpm.
- ▶ Max. torque: 25N-m.
- ▶ Suggested $A_p \leq 3\text{mm}$.
- ▶ Internal coolant not available.
- ▶ Rotating direction opposite to machine spindle.
- ▶ Can be used for ATC.



Reminder:

- ▶ Fix blocks are necessary for installing angle head on the machine [P.5-35~36].
- ▶ Fix blocks are varied by different machine designs. Please confirm the detailed dimensions when ordering.

Optional
Fixed Block



P.5-35~36



SAC ANGLE HEAD HOLDER

FOR MEDIUM CUTTING

SAC 中鋼炮銑削頭

[PNER TYPE]

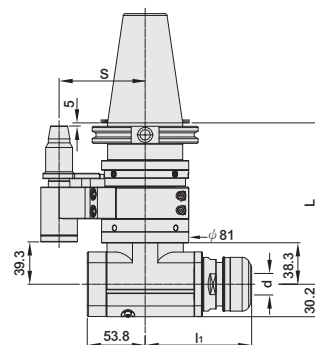

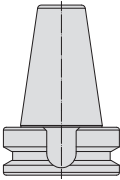
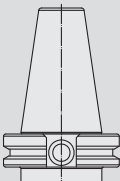
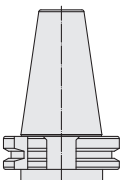
SHANK	MODEL NO.	TYPE	L	l ₁	S	TORQUE	COLLET	SIZE RANGE	WEIGHT (KGS)
 DualDRIVE+	26.770.20.130	SBT40 x SAC20PN - 130	130	91	65	25 N-m	PN20	3 ~ 13	6.40
	26.770.25.130	SBT40 x SAC25PN - 130	130	91	65	25 N-m	PN25	3 ~ 16	6.40
	26.770.32.130	SBT40 x SAC32PN - 130	130	91.4	65	25 N-m	PN32	3 ~ 20	6.44
	27.770.20.147	SBT50 x SAC20PN - 147	147	91	80	25 N-m	PN20	3 ~ 13	6.40
	27.770.25.147	SBT50 x SAC25PN - 147	147	91	80	25 N-m	PN25	3 ~ 16	6.40
	27.770.32.147	SBT50 x SAC32PN - 147	147	91.4	80	25 N-m	PN32	3 ~ 20	6.44
 DualDRIVE+	43.770.20.150	SCAT40 x SAC20PN - 150	150	91	65	25 N-m	PN20	3 ~ 13	6.40
	43.770.25.150	SCAT40 x SAC25PN - 150	150	91	65	25 N-m	PN25	3 ~ 16	6.40
	43.770.32.150	SCAT40 x SAC32PN - 150	150	91.4	65	25 N-m	PN32	3 ~ 20	6.44
	44.770.20.150	SCAT50 x SAC20PN - 150	150	91	80	25 N-m	PN20	3 ~ 13	6.40
	44.770.25.150	SCAT50 x SAC25PN - 150	150	91	80	25 N-m	PN25	3 ~ 16	6.40
	44.770.32.150	SCAT50 x SAC32PN - 150	150	91.4	80	25 N-m	PN32	3 ~ 20	6.44
 DualDRIVE+	66.770.20.146	SDAT40 x SAC20PN - 146	146	91	65	25 N-m	PN20	3 ~ 13	6.40
	66.770.25.146	SDAT40 x SAC25PN - 146	146	91	65	25 N-m	PN25	3 ~ 16	6.40
	66.770.32.146	SDAT40 x SAC32PN - 146	146	91.4	65	25 N-m	PN32	3 ~ 20	6.44
	67.770.20.150	SDAT50 x SAC20PN - 150	150	91	80	25 N-m	PN20	3 ~ 13	6.40
	67.770.25.150	SDAT50 x SAC25PN - 150	150	91	80	25 N-m	PN25	3 ~ 16	6.40
	67.770.32.150	SDAT50 x SAC32PN - 150	150	91.4	80	25 N-m	PN32	3 ~ 20	6.44

Product information:

- ▶ Gear ratio 1:1.
- ▶ Max. revolution: 3000rpm.
- ▶ Max. torque: 25N-m.
- ▶ Suggested $A_p \leq 3\text{mm}$.
- ▶ Internal coolant not available.
- ▶ Rotating direction opposite to machine spindle.
- ▶ Can be used for ATC.



Reminder:

- ▶ Fix blocks are necessary for installing angle head on the machine [P.5-35~36].
- ▶ Fix blocks are varied by different machine designs. Please confirm the detailed dimensions when ordering.

Optional
Fixed Block



P.5-35~36



SAC ANGLE HEAD HOLDER

FOR MEDIUM CUTTING

SAC 中鋼炮銑削頭

[SCA TYPE]

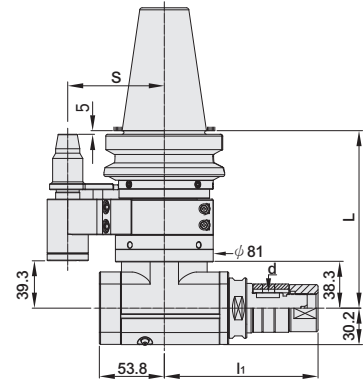

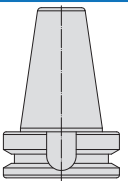
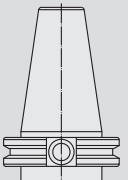
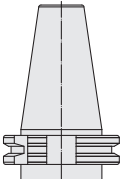
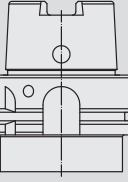
SHANK	MODEL NO.	TYPE	L	l ₁	d	S	TORQUE	WEIGHT (KGS)
 MAS 403	11.770.22.130	BT40 x SAC22SC - 130	130	67.5	22	65	25 N-m	6.40
	11.770.68.130	BT40 x SAC25.4SC - 130	130	67.5	25.4	65	25 N-m	6.40
	12.770.22.147	BT50 x SAC22SC - 147	147	67.5	22	80	25 N-m	6.44
	12.770.68.147	BT50 x SAC25.4SC - 147	147	67.5	25.4	80	25 N-m	6.44
 ANSI B5.50	31.770.22.150	CAT40 x SAC22SC - 150	150	67.5	22	65	25 N-m	6.40
	31.770.68.150	CAT40 x SAC25.4SC - 150	150	67.5	25.4	65	25 N-m	6.40
	32.770.22.150	CAT50 x SAC22SC - 150	150	67.5	22	80	25 N-m	6.44
	32.770.68.150	CAT50 x SAC25.4SC - 150	150	67.5	25.4	80	25 N-m	6.44
 DIN 69871-A	51.770.22.146	DAT40 x SAC22SC - 146	146	67.5	22	65	25 N-m	6.40
	51.770.68.146	DAT40 x SAC25.4SC - 146	146	67.5	25.4	65	25 N-m	6.40
	52.770.22.150	DAT50 x SAC22SC - 150	150	67.5	22	80	25 N-m	6.44
	52.770.68.150	DAT50 x SAC25.4SC - 150	150	67.5	25.4	80	25 N-m	6.44
 DIN 69893 A	73.770.22.155	HSK63A x SAC22SC - 155	155	67.5	22	65	25 N-m	8.40
	73.770.68.155	HSK63A x SAC25.4SC - 155	155	67.5	25.4	65	25 N-m	8.40
	75.770.22.151	HSK100A x SAC22SC - 151	151	67.5	22	80	25 N-m	8.40
	75.770.68.151	HSK100A x SAC25.4SC - 151	151	67.5	25.4	80	25 N-m	8.40

Product information:

- ▶ Gear ratio 1:1.
- ▶ Max. revolution: 3000rpm.
- ▶ Max. torque: 25N-m.
- ▶ Suggested $A_p \leq 3\text{mm}$.
- ▶ Internal coolant not available.
- ▶ Rotating direction opposite to machine spindle.
- ▶ Can be used for ATC.



Reminder:

- ▶ Fix blocks are necessary for installing angle head on the machine [P.5-35~36].
- ▶ Fix blocks are varied by different machine designs. Please confirm the detailed dimensions when ordering.

Optional
Fixed Block



P.5-35~36



SAC ANGLE HEAD HOLDER

FOR MEDIUM CUTTING

SAC 中鋼炮銑削頭

[SCA TYPE]

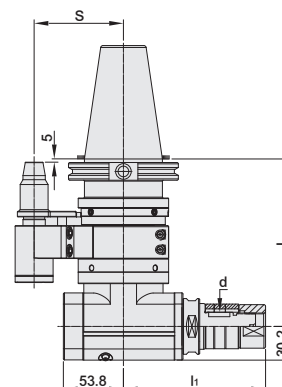

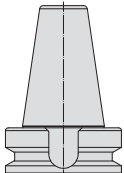
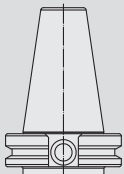
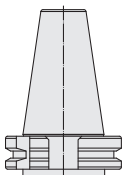
SHANK	MODEL NO.	TYPE	L	li	d	s	TORQUE	WEIGHT (KGS)
 DualDRIVE+	26.770.22.130	SBT40 x SAC22SC - 130	130	67.5	22	65	25 N-m	6.40
	26.770.68.130	SBT40 x SAC25.4SC - 130	130	67.5	25.4	65	25 N-m	6.40
	27.770.22.147	SBT50 x SAC22SC - 147	147	67.5	22	80	25 N-m	6.44
	27.770.68.147	SBT50 x SAC25.4SC - 147	147	67.5	25.4	80	25 N-m	6.44
 DualDRIVE+	43.770.22.150	SCAT40 x SAC22SC - 150	150	67.5	22	65	25 N-m	6.40
	43.770.68.150	SCAT40 x SAC25.4SC - 150	150	67.5	25.4	65	25 N-m	6.40
	44.770.22.150	SCAT50 x SAC22SC - 150	150	67.5	22	80	25 N-m	6.44
	44.770.68.150	SCAT50 x SAC25.4SC - 150	150	67.5	25.4	80	25 N-m	6.44
 DualDRIVE+	66.770.22.146	SDAT40 x SAC22SC - 146	146	67.5	22	65	25 N-m	6.40
	66.770.68.146	SDAT40 x SAC25.4SC - 146	146	67.5	25.4	65	25 N-m	6.40
	67.770.22.150	SDAT50 x SAC22SC - 150	150	67.5	22	80	25 N-m	6.44
	67.770.68.150	SDAT50 x SAC25.4SC - 150	150	67.5	25.4	80	25 N-m	6.44

Product information:

- ▶ Gear ratio 1:1.
- ▶ Max. revolution: 3000rpm.
- ▶ Max. torque: 25N-m.
- ▶ Suggested $A_p \leq 3\text{mm}$.
- ▶ Internal coolant not available.
- ▶ Rotating direction opposite to machine spindle.
- ▶ Can be used for ATC.



Reminder:

- ▶ Fix blocks are necessary for installing angle head on the machine [P.5-35~36].
- ▶ Fix blocks are varied by different machine designs. Please confirm the detailed dimensions when ordering.

Optional
Fixed Block



P.5-35~36



SAM ANGLE HEAD HOLDER

FOR LIGHT CUTTING

SAM 小鋼炮銑削頭

(SKS TYPE)

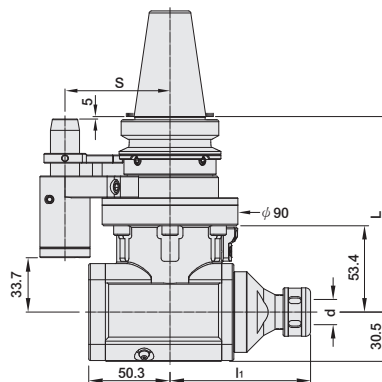

WITH COOLANT SYSTEM

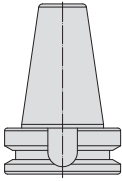
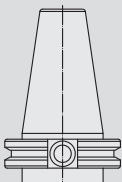
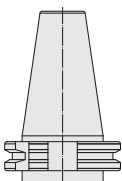
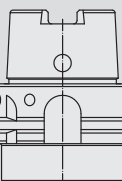
SHANK	MODEL NO.	TYPE	L	l ₁	S	TORQUE	COLLET	d SIZE RANGE	WEIGHT (KGS)
 MAS 403	11.635.10.120	BT40 x SAM10S - 120	120	87	65	20 N-m	SKS10	3 ~ 10	5.20
	11.635.13.120	BT40 x SAM13S - 120	120	87	65	20 N-m	SKS13	3 ~ 13	5.20
	11.635.16.120	BT40 x SAM16S - 120	120	89.5	65	20 N-m	SKS16	3 ~ 16	5.20
	11.635.20.120	BT40 x SAM20S - 120	120	90	65	20 N-m	SKS20	3 ~ 20	5.20
	12.635.10.130	BT50 x SAM10S - 130	130	87	80	20 N-m	SKS10	3 ~ 10	6.30
	12.635.13.130	BT50 x SAM13S - 130	130	87	80	20 N-m	SKS13	3 ~ 13	6.30
	12.635.16.130	BT50 x SAM16S - 130	130	89.5	80	20 N-m	SKS16	3 ~ 16	6.30
	12.635.20.130	BT50 x SAM20S - 130	130	90	80	20 N-m	SKS20	3 ~ 20	6.30
 ANSI B5.50	31.635.10.537	CAT40 x SAM10S - 5.372"	5.372	3.425	65	20 N-m	SKS10	3 ~ 10	5.20
	31.635.13.537	CAT40 x SAM13S - 5.372"	5.372	3.425	65	20 N-m	SKS13	3 ~ 13	5.20
	31.635.16.537	CAT40 x SAM16S - 5.372"	5.372	3.524	65	20 N-m	SKS16	3 ~ 16	5.20
	31.635.20.537	CAT40 x SAM20S - 5.372"	5.372	3.543	65	20 N-m	SKS20	3 ~ 20	5.20
	32.635.10.550	CAT50 x SAM10S - 5.5"	5.5	3.425	80	20 N-m	SKS10	3 ~ 10	6.30
	32.635.13.550	CAT50 x SAM13S - 5.5"	5.5	3.425	80	20 N-m	SKS13	3 ~ 13	6.30
	32.635.16.550	CAT50 x SAM16S - 5.5"	5.5	3.524	80	20 N-m	SKS16	3 ~ 16	6.30
	32.635.20.550	CAT50 x SAM20S - 5.5"	5.5	3.543	80	20 N-m	SKS20	3 ~ 20	6.30
 DIN 69871-A	51.635.10.136	DAT40 x SAM10S - 136.45	136.45	87	65	20 N-m	SKS10	3 ~ 10	5.20
	51.635.13.136	DAT40 x SAM13S - 136.45	136.45	87	65	20 N-m	SKS13	3 ~ 13	5.20
	51.635.16.136	DAT40 x SAM16S - 136.45	136.45	89.5	65	20 N-m	SKS16	3 ~ 16	5.20
	51.635.20.136	DAT40 x SAM20S - 136.45	136.45	90	65	20 N-m	SKS20	3 ~ 20	5.20
	52.635.10.139	DAT50 x SAM10S - 139.7	139.7	87	80	20 N-m	SKS10	3 ~ 10	6.30
	52.635.13.139	DAT50 x SAM13S - 139.7	139.7	87	80	20 N-m	SKS13	3 ~ 13	6.30
	52.635.16.139	DAT50 x SAM16S - 139.7	139.7	89.5	80	20 N-m	SKS16	3 ~ 16	6.30
	52.635.20.139	DAT50 x SAM20S - 139.7	139.7	90	80	20 N-m	SKS20	3 ~ 20	6.30
 DIN 69893 A	73.635.10.145	HSK63A x SAM10S - 145	145	87	65	20 N-m	SKS10	3 ~ 10	5.20
	73.635.13.145	HSK63A x SAM13S - 145	145	87	65	20 N-m	SKS13	3 ~ 13	5.20
	73.635.16.145	HSK63A x SAM16S - 145	145	89.5	65	20 N-m	SKS16	3 ~ 16	5.20
	73.635.20.145	HSK63A x SAM20S - 145	145	90	65	20 N-m	SKS20	3 ~ 20	5.20
	75.635.10.150	HSK100A x SAM10S - 150	150	87	80	20 N-m	SKS10	3 ~ 10	6.30
	75.635.13.150	HSK100A x SAM13S - 150	150	87	80	20 N-m	SKS13	3 ~ 13	6.30
	75.635.16.150	HSK100A x SAM16S - 150	150	89.5	80	20 N-m	SKS16	3 ~ 16	6.30
	75.635.20.150	HSK100A x SAM20S - 150	150	90	80	20 N-m	SKS20	3 ~ 20	6.30

Product information: ▶ Gear ratio 1:1. ▶ Max. revolution: 4000rpm. ▶ Max. torque: 20N-m. ▶ Suggested $A_p \leq 2$ mm. ▶ Can be used for ATC.
 ▶ Coolant feed through spindle or dowel pin, coolant outlet from cutting tools or coolant nozzles. ▶ Max. water pressure: 7kgf/cm²(100PSI).
 ▶ Rotating direction opposite to machine spindle.



Reminder:

- ▶ Fix blocks are necessary for installing angle head on the machine [P.5-35~36].
- ▶ Fix blocks are varied by different machine designs. Please confirm the detailed dimensions when ordering.

Optional
Fixed Block



P.5-35~36



SAM ANGLE HEAD HOLDER

FOR LIGHT CUTTING

SAM 小鋼炮銑削頭

(SKS TYPE)

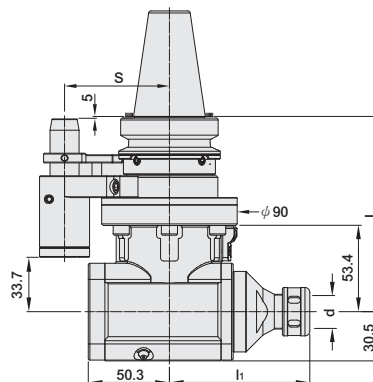

WITH COOLANT SYSTEM

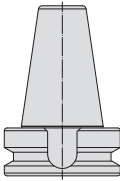
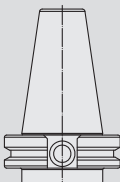
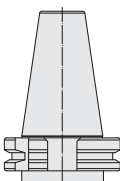
SHANK	MODEL NO.	TYPE	L	l ₁	S	TORQUE	COLLET	SIZE RANGE	WEIGHT (KGS)
 DualDRIVE+	26.635.10.120	SBT40 x SAM10S - 120	120	87	65	20 N-m	SKS10	3 ~ 10	5.20
	26.635.13.120	SBT40 x SAM13S - 120	120	87	65	20 N-m	SKS13	3 ~ 13	5.20
	26.635.16.120	SBT40 x SAM16S - 120	120	89.5	65	20 N-m	SKS16	3 ~ 16	5.20
	26.635.20.120	SBT40 x SAM20S - 120	120	90	65	20 N-m	SKS20	3 ~ 20	5.20
	27.635.10.130	SBT50 x SAM10S - 130	130	87	80	20 N-m	SKS10	3 ~ 10	6.30
	27.635.13.130	SBT50 x SAM13S - 130	130	87	80	20 N-m	SKS13	3 ~ 13	6.30
	27.635.16.130	SBT50 x SAM16S - 130	130	89.5	80	20 N-m	SKS16	3 ~ 16	6.30
	27.635.20.130	SBT50 x SAM20S - 130	130	90	80	20 N-m	SKS20	3 ~ 20	6.30
 DualDRIVE+	43.635.10.537	SCAT40 x SAM10S - 5.372"	5.372	3.425	2.559	20 N-m	SKS10	3 ~ 10	5.20
	43.635.13.537	SCAT40 x SAM13S - 5.372"	5.372	3.425	2.559	20 N-m	SKS13	3 ~ 13	5.20
	43.635.16.537	SCAT40 x SAM16S - 5.372"	5.372	3.425	2.559	20 N-m	SKS16	3 ~ 16	5.20
	43.635.20.537	SCAT40 x SAM20S - 5.372"	5.372	3.228	2.559	20 N-m	SKS20	3 ~ 20	5.20
	44.635.10.550	SCAT50 x SAM10S - 5.5"	5.5	3.425	3.145	20 N-m	SKS10	3 ~ 10	6.30
	44.635.13.550	SCAT50 x SAM13S - 5.5"	5.5	3.425	3.145	20 N-m	SKS13	3 ~ 13	6.30
	44.635.16.550	SCAT50 x SAM16S - 5.5"	5.5	3.425	3.145	20 N-m	SKS16	3 ~ 16	6.30
	44.635.20.550	SCAT50 x SAM20S - 5.5"	5.5	3.228	3.145	20 N-m	SKS20	3 ~ 20	6.30
 DualDRIVE+	66.635.10.136	SDAT40 x SAM10S - 136.45	136.45	87	65	20 N-m	SKS10	3 ~ 10	5.20
	66.635.13.136	SDAT40 x SAM13S - 136.45	136.45	87	65	20 N-m	SKS13	3 ~ 13	5.20
	66.635.16.136	SDAT40 x SAM16S - 136.45	136.45	89.5	65	20 N-m	SKS16	3 ~ 16	5.20
	66.635.20.136	SDAT40 x SAM20S - 136.45	136.45	90	65	20 N-m	SKS20	3 ~ 20	5.20
	67.635.10.139	SDAT50 x SAM10S - 139.7	139.7	87	80	20 N-m	SKS10	3 ~ 10	6.30
	67.635.13.139	SDAT50 x SAM13S - 139.7	139.7	87	80	20 N-m	SKS13	3 ~ 13	6.30
	67.635.16.139	SDAT50 x SAM16S - 139.7	139.7	89.5	80	20 N-m	SKS16	3 ~ 16	6.30
	67.635.20.139	SDAT50 x SAM20S - 139.7	139.7	90	80	20 N-m	SKS20	3 ~ 20	6.30

Product information:

- ▶ Gear ratio 1:1.
- ▶ Max. revolution: 4000rpm.
- ▶ Max. torque: 20N-m.
- ▶ Suggested $A_p \leq 2\text{mm}$.
- ▶ Coolant feed through spindle or dowel pin, coolant outlet from cutting tools or coolant nozzles.
- ▶ Max. water pressure: 7kgf/cm^2 (100PSI).
- ▶ Rotating direction opposite to machine spindle.
- ▶ Can be used for ATC.



Reminder:

- ▶ Fix blocks are necessary for installing angle head on the machine [P.5-35~36].
- ▶ Fix blocks are varied by different machine designs. Please confirm the detailed dimensions when ordering.

Optional
Fixed Block



P.5-35~36



SAM ANGLE HEAD HOLDER

FOR LIGHT CUTTING

SAM 小鋼炮銑削頭

(SKS TYPE)

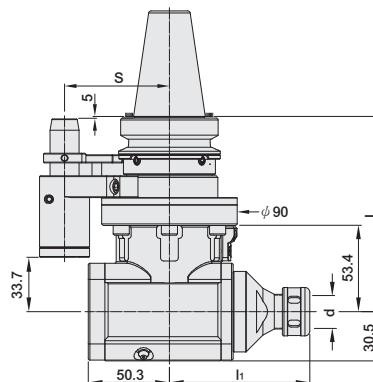

WITHOUT COOLANT SYSTEM

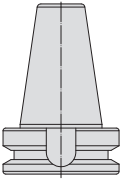
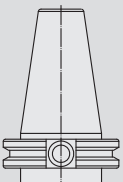
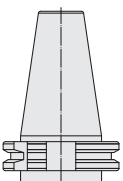
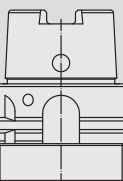
SHANK	MODEL NO.	TYPE	L	l ₁	S	TORQUE	COLLET	SIZE RANGE	WEIGHT (KGS)
 MAS 403	11.635X.10.120	BT40 x SAM10SX - 120	120	87	65	20 N-m	SKS10	3 ~ 10	6.40
	11.635X.13.120	BT40 x SAM13SX - 120	120	87	65	20 N-m	SKS13	3 ~ 13	6.40
	11.635X.16.120	BT40 x SAM16SX - 120	120	89.5	65	20 N-m	SKS16	3 ~ 16	6.40
	11.635X.20.120	BT40 x SAM20SX - 120	120	90	65	20 N-m	SKS20	3 ~ 20	6.40
	12.635X.10.130	BT50 x SAM10SX - 130	130	87	80	20 N-m	SKS10	3 ~ 10	8.40
	12.635X.13.130	BT50 x SAM13SX - 130	130	87	80	20 N-m	SKS13	3 ~ 13	8.40
	12.635X.16.130	BT50 x SAM16SX - 130	130	89.5	80	20 N-m	SKS16	3 ~ 16	8.40
 ANSI B5.50	12.635X.20.130	BT50 x SAM20SX - 130	130	90	80	20 N-m	SKS20	3 ~ 20	8.40
	31.635X.10.537	CAT40 x SAM10SX - 5.372"	5.372	3.425	2.559	20 N-m	SKS10	3 ~ 10	6.40
	31.635X.13.537	CAT40 x SAM13SX - 5.372"	5.372	3.425	2.559	20 N-m	SKS13	3 ~ 13	6.40
	31.635X.16.537	CAT40 x SAM16SX - 5.372"	5.372	3.524	2.559	20 N-m	SKS16	3 ~ 16	6.40
	31.635X.20.537	CAT40 x SAM20SX - 5.372"	5.372	3.543	2.559	20 N-m	SKS20	3 ~ 20	6.40
	32.635X.10.550	CAT50 x SAM10SX - 5.5"	5.5	3.425	3.145	20 N-m	SKS10	3 ~ 10	8.40
	32.635X.13.550	CAT50 x SAM13SX - 5.5"	5.5	3.425	3.145	20 N-m	SKS13	3 ~ 13	8.40
 DIN 69871-A	32.635X.16.550	CAT50 x SAM16SX - 5.5"	5.5	3.524	3.145	20 N-m	SKS16	3 ~ 16	8.40
	32.635X.20.550	CAT50 x SAM20SX - 5.5"	5.5	3.543	3.145	20 N-m	SKS20	3 ~ 20	8.40
	51.635X.10.136	DAT40 x SAM10SX - 136.45	136.45	87	65	20 N-m	SKS10	3 ~ 10	6.40
	51.635X.13.136	DAT40 x SAM13SX - 136.45	136.45	87	65	20 N-m	SKS13	3 ~ 13	6.40
	51.635X.16.136	DAT40 x SAM16SX - 136.45	136.45	89.5	65	20 N-m	SKS16	3 ~ 16	6.40
	51.635X.20.136	DAT40 x SAM20SX - 136.45	136.45	90	65	20 N-m	SKS20	3 ~ 20	6.40
	52.635X.10.139	DAT50 x SAM10SX - 139.7	139.7	87	80	20 N-m	SKS10	3 ~ 10	8.40
 DIN 69893 A	52.635X.13.139	DAT50 x SAM13SX - 139.7	139.7	87	80	20 N-m	SKS13	3 ~ 13	8.40
	52.635X.16.139	DAT50 x SAM16SX - 139.7	139.7	89.5	80	20 N-m	SKS16	3 ~ 16	8.40
	52.635X.20.139	DAT50 x SAM20SX - 139.7	139.7	90	80	20 N-m	SKS20	3 ~ 20	8.40
	73.635X.10.145	HSK63A x SAM10SX - 145	145	87	65	20 N-m	SKS10	3 ~ 10	6.40
	73.635X.13.145	HSK63A x SAM13SX - 145	145	87	65	20 N-m	SKS13	3 ~ 13	6.40
	73.635X.16.145	HSK63A x SAM16SX - 145	145	89.5	65	20 N-m	SKS16	3 ~ 16	6.40
	73.635X.20.145	HSK63A x SAM20SX - 145	145	90	65	20 N-m	SKS20	3 ~ 20	6.40
	75.635X.10.150	HSK100A x SAM10SX - 150	150	87	80	20 N-m	SKS10	3 ~ 10	8.40
	75.635X.13.150	HSK100A x SAM13SX - 150	150	87	80	20 N-m	SKS13	3 ~ 13	8.40
	75.635X.16.150	HSK100A x SAM16SX - 150	150	89.5	80	20 N-m	SKS16	3 ~ 16	8.40
	75.635X.20.150	HSK100A x SAM20SX - 150	150	90	80	20 N-m	SKS20	3 ~ 20	8.40

Product information: ▶ Gear ratio 1:1. ▶ Max. revolution: 4000rpm. ▶ Max. torque: 20N-m. ▶ Suggested $A_p \leq 2\text{mm}$.
 ▶ Internal coolant not available. ▶ Rotating direction opposite to machine spindle.
 ▶ Can be used for ATC.



Reminder:

- ▶ Fix blocks are necessary for installing angle head on the machine [P.5-35~36].
- ▶ Fix blocks are varied by different machine designs. Please confirm the detailed dimensions when ordering.

Optional
Fixed Block



P.5-35~36



SAM ANGLE HEAD HOLDER

FOR LIGHT CUTTING

SAM 小鋼炮銑削頭

(SKS TYPE)

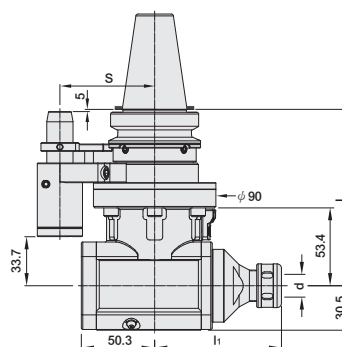

WITHOUT COOLANT SYSTEM

SHANK	MODEL NO.	TYPE	L	l ₁	S	TORQUE	COLLET	SIZE RANGE	WEIGHT (KGS)
DualDRIVE+	26.635X.10.120	SBT40 x SAM10SX - 120	120	87	65	20 N-m	SKS10	3 ~ 10	6.40
	26.635X.13.120	SBT40 x SAM13SX - 120	120	87	65	20 N-m	SKS13	3 ~ 13	6.40
	26.635X.16.120	SBT40 x SAM16SX - 120	120	89.5	65	20 N-m	SKS16	3 ~ 16	6.40
	26.635X.20.120	SBT40 x SAM20SX - 120	120	90	65	20 N-m	SKS20	3 ~ 20	6.40
	27.635X.10.130	SBT50 x SAM10SX - 130	130	87	80	20 N-m	SKS10	3 ~ 10	8.40
	27.635X.13.130	SBT50 x SAM13SX - 130	130	87	80	20 N-m	SKS13	3 ~ 13	8.40
	27.635X.16.130	SBT50 x SAM16SX - 130	130	89.5	80	20 N-m	SKS16	3 ~ 16	8.40
DualDRIVE+	27.635X.20.130	SBT50 x SAM20SX - 130	130	90	80	20 N-m	SKS20	3 ~ 20	8.40
	43.635X.10.537	SCAT40 x SAM10SX - 5.372"	5.372	3.425	2.559	20 N-m	SKS10	3 ~ 10	6.40
	43.635X.13.537	SCAT40 x SAM13SX - 5.372"	5.372	3.425	2.559	20 N-m	SKS13	3 ~ 13	6.40
	43.635X.16.537	SCAT40 x SAM16SX - 5.372"	5.372	3.425	2.559	20 N-m	SKS16	3 ~ 16	6.40
	43.635X.20.537	SCAT40 x SAM20SX - 5.372"	5.372	3.228	2.559	20 N-m	SKS20	3 ~ 20	6.40
	44.635X.10.550	SCAT50 x SAM10SX - 5.5"	5.5	3.425	3.145	20 N-m	SKS10	3 ~ 10	8.40
	44.635X.13.550	SCAT50 x SAM13SX - 5.5"	5.5	3.425	3.145	20 N-m	SKS13	3 ~ 13	8.40
DualDRIVE+	44.635X.16.550	SCAT50 x SAM16SX - 5.5"	5.5	3.425	3.145	20 N-m	SKS16	3 ~ 16	8.40
	44.635X.20.550	SCAT50 x SAM20SX - 5.5"	5.5	3.228	3.145	20 N-m	SKS20	3 ~ 20	8.40
	66.635X.10.136	SDAT40 x SAM10SX - 136.45	136.45	87	65	20 N-m	SKS10	3 ~ 10	6.40
	66.635X.13.136	SDAT40 x SAM13SX - 136.45	136.45	87	65	20 N-m	SKS13	3 ~ 13	6.40
	66.635X.16.136	SDAT40 x SAM16SX - 136.45	136.45	89.5	65	20 N-m	SKS16	3 ~ 16	6.40
	66.635X.20.136	SDAT40 x SAM20SX - 136.45	136.45	90	65	20 N-m	SKS20	3 ~ 20	6.40
	67.635X.10.139	SDAT50 x SAM10SX - 139.7	139.7	87	80	20 N-m	SKS10	3 ~ 10	8.40
	67.635X.13.139	SDAT50 x SAM13SX - 139.7	139.7	87	80	20 N-m	SKS13	3 ~ 13	8.40
	67.635X.16.139	SDAT50 x SAM16SX - 139.7	139.7	89.5	80	20 N-m	SKS16	3 ~ 16	8.40
67.635X.20.139	SDAT50 x SAM20SX - 139.7	139.7	90	80	20 N-m	SKS20	3 ~ 20	8.40	

Product information:

- ▶ Gear ratio 1:1.
- ▶ Max. revolution: 4000rpm.
- ▶ Max. torque: 20N-m.
- ▶ Suggested $A_p \leq 2\text{mm}$.
- ▶ Internal coolant not available.
- ▶ Rotating direction opposite to machine spindle.
- ▶ Can be used for ATC.



Reminder:

- ▶ Fix blocks are necessary for installing angle head on the machine [P.5-35~36].
- ▶ Fix blocks are varied by different machine designs. Please confirm the detailed dimensions when ordering.

Optional
Fixed Block



P.5-35~36



SAM ANGLE HEAD HOLDER

FOR LIGHT CUTTING

SAM 小鋼炮銑削頭

(ER TYPE)

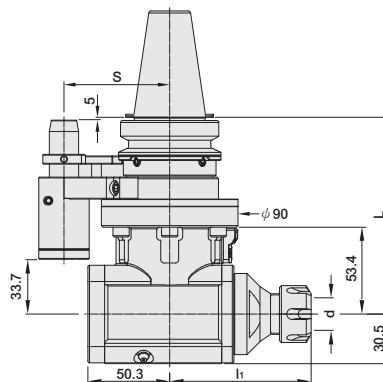

WITH COOLANT SYSTEM

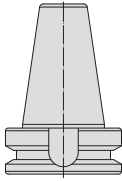
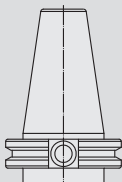
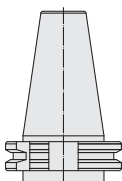
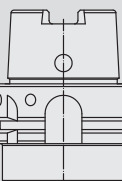
SHANK	MODEL NO.	TYPE	L	l ₁	S	TORQUE	COLLET	SIZE RANGE	WEIGHT (KGS)
 MAS 403	11.636.16.120	BT40 x SAM16E - 120	120	87	65	20 N-m	ER16	1 ~ 10	6.40
	11.636.20.120	BT40 x SAM20E - 120	120	87	65	20 N-m	ER20	1 ~ 13	6.40
	11.636.25.120	BT40 x SAM25E - 120	120	87	65	20 N-m	ER25	1 ~ 16	6.40
	11.636.32.120	BT40 x SAM32E - 120	120	82	65	20 N-m	ER32	2 ~ 20	6.44
	12.636.16.130	BT50 x SAM16E - 130	130	87	80	20 N-m	ER16	1 ~ 10	8.40
	12.636.20.130	BT50 x SAM20E - 130	130	87	80	20 N-m	ER20	1 ~ 13	8.40
	12.636.25.130	BT50 x SAM25E - 130	130	87	80	20 N-m	ER25	1 ~ 16	8.40
	12.636.32.130	BT50 x SAM32E - 130	130	82	80	20 N-m	ER32	2 ~ 20	8.44
 ANSI B5.50	31.636.16.537	CAT40 x SAM16E - 5.372"	5.372	3.425	2.559	20 N-m	ER16	1 ~ 10	6.40
	31.636.20.537	CAT40 x SAM20E - 5.372"	5.372	3.425	2.559	20 N-m	ER20	1 ~ 13	6.40
	31.636.25.537	CAT40 x SAM25E - 5.372"	5.372	3.425	2.559	20 N-m	ER25	1 ~ 16	6.40
	31.636.32.537	CAT40 x SAM32E - 5.372"	5.372	3.228	2.559	20 N-m	ER32	2 ~ 20	6.44
	32.636.16.550	CAT50 x SAM16E - 5.5"	5.5	3.425	3.145	20 N-m	ER16	1 ~ 10	8.40
	32.636.20.550	CAT50 x SAM20E - 5.5"	5.5	3.425	3.145	20 N-m	ER20	1 ~ 13	8.40
	32.636.25.550	CAT50 x SAM25E - 5.5"	5.5	3.425	3.145	20 N-m	ER25	1 ~ 16	8.40
	32.636.32.550	CAT50 x SAM32E - 5.5"	5.5	3.228	3.145	20 N-m	ER32	2 ~ 20	8.44
 DIN 69871-A	51.636.16.136	DAT40 x SAM16E - 136.45	136.45	87	65	20 N-m	ER16	1 ~ 10	6.40
	51.636.20.136	DAT40 x SAM20E - 136.45	136.45	87	65	20 N-m	ER20	1 ~ 13	6.40
	51.636.25.136	DAT40 x SAM25E - 136.45	136.45	87	65	20 N-m	ER25	1 ~ 16	6.40
	51.636.32.136	DAT40 x SAM32E - 136.45	136.45	82	65	20 N-m	ER32	2 ~ 20	6.44
	52.636.16.139	DAT50 x SAM16E - 139.7	139.7	87	80	20 N-m	ER16	1 ~ 10	8.40
	52.636.20.139	DAT50 x SAM20E - 139.7	139.7	87	80	20 N-m	ER20	1 ~ 13	8.40
	52.636.25.139	DAT50 x SAM25E - 139.7	139.7	87	80	20 N-m	ER25	1 ~ 16	8.40
	52.636.32.139	DAT50 x SAM32E - 139.7	139.7	82	80	20 N-m	ER32	2 ~ 20	8.44
 DIN 69893 A	73.636.16.145	HSK63A x SAM16E - 145	145	87	65	20 N-m	ER16	1 ~ 10	6.40
	73.636.20.145	HSK63A x SAM20E - 145	145	87	65	20 N-m	ER20	1 ~ 13	6.40
	73.636.25.145	HSK63A x SAM25E - 145	145	87	65	20 N-m	ER25	1 ~ 16	6.40
	73.636.32.145	HSK63A x SAM32E - 145	145	82	65	20 N-m	ER32	2 ~ 20	6.44
	75.636.16.150	HSK100A x SAM16E - 150	150	87	80	20 N-m	ER16	1 ~ 10	8.40
	75.636.20.150	HSK100A x SAM20E - 150	150	87	80	20 N-m	ER20	1 ~ 13	8.40
	75.636.25.150	HSK100A x SAM25E - 150	150	87	80	20 N-m	ER25	1 ~ 16	8.40
	75.636.32.150	HSK100A x SAM32E - 150	150	82	80	20 N-m	ER32	2 ~ 20	8.44

Product information: ▶ Gear ratio 1:1. ▶ Max. revolution: 4000rpm. ▶ Max. torque: 20N-m. ▶ Suggested Ap ≤ 2mm.
 ▶ Coolant feed through spindle or dowel pin, coolant outlet from cutting tools or coolant nozzles. ▶ Max. water pressure: 7kgf/cm²(100PSI).
 ▶ Rotating direction opposite to machine spindle. ▶ Can be used for ATC.



Reminder:

- ▶ Fix blocks are necessary for installing angle head on the machine [P.5-35~36].
- ▶ Fix blocks are varied by different machine designs. Please confirm the detailed dimensions when ordering.

Optional
Fixed Block



P.5-35~36



SAM ANGLE HEAD HOLDER

FOR LIGHT CUTTING

SAM 小鋼炮銑削頭

(ER TYPE)

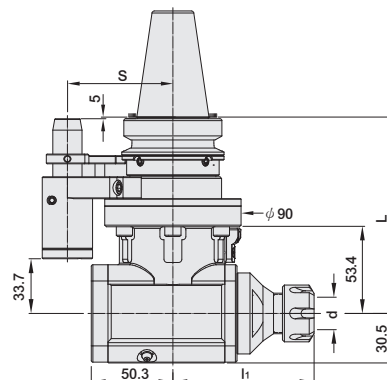

WITH COOLANT SYSTEM

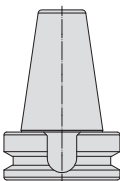
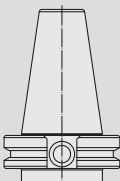
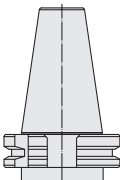
SHANK	MODEL NO.	TYPE	L	l ₁	S	TORQUE	COLLET	SIZE RANGE ^d	WEIGHT (KGS)
 DualDRIVE+	26.636.16.120	SBT40 x SAM16E - 120	120	87	65	20 N-m	ER16	1 ~ 10	6.40
	26.636.20.120	SBT40 x SAM20E - 120	120	87	65	20 N-m	ER20	1 ~ 13	6.40
	26.636.25.120	SBT40 x SAM25E - 120	120	87	65	20 N-m	ER25	1 ~ 16	6.40
	26.636.32.120	SBT40 x SAM32E - 120	120	82	65	20 N-m	ER32	2 ~ 20	6.44
	27.636.16.130	SBT50 x SAM16E - 130	130	87	80	20 N-m	ER16	1 ~ 10	8.40
	27.636.20.130	SBT50 x SAM20E - 130	130	87	80	20 N-m	ER20	1 ~ 13	8.40
	27.636.25.130	SBT50 x SAM25E - 130	130	87	80	20 N-m	ER25	1 ~ 16	8.40
 DualDRIVE+	27.636.32.130	SBT50 x SAM32E - 130	130	82	80	20 N-m	ER32	2 ~ 20	8.44
	43.636.16.537	SCAT40 x SAM16E - 5.372"	5.372	3.425	2.559	20 N-m	ER16	1 ~ 10	6.40
	43.636.20.537	SCAT40 x SAM20E - 5.372"	5.372	3.425	2.559	20 N-m	ER20	1 ~ 13	6.40
	43.636.25.537	SCAT40 x SAM25E - 5.372"	5.372	3.425	2.559	20 N-m	ER25	1 ~ 16	6.40
	43.636.32.537	SCAT40 x SAM32E - 5.372"	5.372	3.228	2.559	20 N-m	ER32	2 ~ 20	6.44
	44.636.16.550	SCAT50 x SAM16E - 5.5"	5.5	3.425	3.145	20 N-m	ER16	1 ~ 10	8.40
	44.636.20.550	SCAT50 x SAM20E - 5.5"	5.5	3.425	3.145	20 N-m	ER20	1 ~ 13	8.40
 DualDRIVE+	44.636.25.550	SCAT50 x SAM25E - 5.5"	5.5	3.425	3.145	20 N-m	ER25	1 ~ 16	8.40
	44.636.32.550	SCAT50 x SAM32E - 5.5"	5.5	3.228	3.145	20 N-m	ER32	2 ~ 20	8.44
	66.636.16.136	SDAT40 x SAM16E - 136.45	136.45	87	65	20 N-m	ER16	1 ~ 10	6.40
	66.636.20.136	SDAT40 x SAM20E - 136.45	136.45	87	65	20 N-m	ER20	1 ~ 13	6.40
	66.636.25.136	SDAT40 x SAM25E - 136.45	136.45	87	65	20 N-m	ER25	1 ~ 16	6.40
	66.636.32.136	SDAT40 x SAM32E - 136.45	136.45	82	65	20 N-m	ER32	2 ~ 20	6.44
	67.636.16.139	SDAT50 x SAM16E - 139.7	139.7	87	80	20 N-m	ER16	1 ~ 10	8.40
	67.636.20.139	SDAT50 x SAM20E - 139.7	139.7	87	80	20 N-m	ER20	1 ~ 13	8.40
	67.636.25.139	SDAT50 x SAM25E - 139.7	139.7	87	80	20 N-m	ER25	1 ~ 16	8.40
67.636.32.139	SDAT50 x SAM32E - 139.7	139.7	82	80	20 N-m	ER32	2 ~ 20	8.44	

Product information:

- ▶ Gear ratio 1:1.
- ▶ Max. revolution: 4000rpm.
- ▶ Max. torque: 20N-m.
- ▶ Suggested $A_p \leq 2\text{mm}$.
- ▶ Coolant feed through spindle or dowel pin, coolant outlet from cutting tools or coolant nozzles.
- ▶ Max. water pressure: 7kgf/cm^2 (100PSI).
- ▶ Rotating direction opposite to machine spindle.
- ▶ Can be used for ATC.



Reminder:

- ▶ Fix blocks are necessary for installing angle head on the machine [P.5-35~36].
- ▶ Fix blocks are varied by different machine designs. Please confirm the detailed dimensions when ordering.

Optional
Fixed Block



P.5-35~36



SAM ANGLE HEAD HOLDER

FOR LIGHT CUTTING

SAM 小鋼炮銑削頭

(ER TYPE)

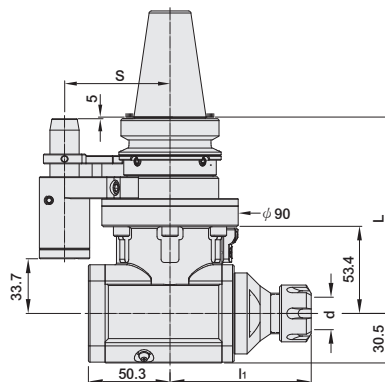

WITHOUT COOLANT SYSTEM

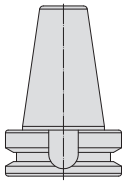
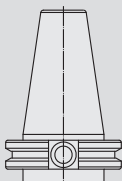
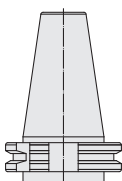
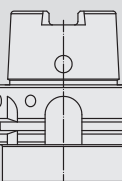
SHANK	MODEL NO.	TYPE	L	h ₁	S	TORQUE	COLLET	SIZE d RANGE	WEIGHT (KGS)
 <p>MAS 403</p>	11.636X.16.120	BT40 x SAM16EX - 120	120	87	65	20 N-m	ER16	1 ~ 10	5.20
	11.636X.20.120	BT40 x SAM20EX - 120	120	87	65	20 N-m	ER20	1 ~ 13	5.20
	11.636X.25.120	BT40 x SAM25EX - 120	120	87	65	20 N-m	ER25	1 ~ 16	5.20
	11.636X.32.120	BT40 x SAM32EX - 120	120	82	65	20 N-m	ER32	2 ~ 20	7.76
	12.636X.16.130	BT50 x SAM16EX - 130	130	87	80	20 N-m	ER16	1 ~ 10	6.30
	12.636X.20.130	BT50 x SAM20EX - 130	130	87	80	20 N-m	ER20	1 ~ 13	6.30
	12.636X.25.130	BT50 x SAM25EX - 130	130	87	80	20 N-m	ER25	1 ~ 16	6.30
	12.636X.32.130	BT50 x SAM32EX - 130	130	82	80	20 N-m	ER32	2 ~ 20	8.86
 <p>ANSI B5.50</p>	31.636X.16.537	CAT40 x SAM16EX - 5.372"	5.372	3.425	2.559	20 N-m	ER16	1 ~ 10	5.20
	31.636X.20.537	CAT40 x SAM20EX - 5.372"	5.372	3.425	2.559	20 N-m	ER20	1 ~ 13	5.20
	31.636X.25.537	CAT40 x SAM25EX - 5.372"	5.372	3.425	2.559	20 N-m	ER25	1 ~ 16	5.20
	31.636X.32.537	CAT40 x SAM32EX - 5.372"	5.372	3.228	2.559	20 N-m	ER32	2 ~ 20	7.76
	32.636X.16.550	CAT50 x SAM16EX - 5.5"	5.5	3.425	3.145	20 N-m	ER16	1 ~ 10	6.30
	32.636X.20.550	CAT50 x SAM20EX - 5.5"	5.5	3.425	3.145	20 N-m	ER20	1 ~ 13	6.30
	32.636X.25.550	CAT50 x SAM25EX - 5.5"	5.5	3.425	3.145	20 N-m	ER25	1 ~ 16	6.30
	32.636X.32.550	CAT50 x SAM32EX - 5.5"	5.5	3.228	3.145	20 N-m	ER32	2 ~ 20	8.86
 <p>DIN 69871-A</p>	51.636X.16.136	DAT40 x SAM16EX - 136.45	136.45	87	65	20 N-m	ER16	1 ~ 10	5.20
	51.636X.20.136	DAT40 x SAM20EX - 136.45	136.45	87	65	20 N-m	ER20	1 ~ 13	5.20
	51.636X.25.136	DAT40 x SAM25EX - 136.45	136.45	87	65	20 N-m	ER25	1 ~ 16	5.20
	51.636X.32.136	DAT40 x SAM32EX - 136.45	136.45	82	65	20 N-m	ER32	2 ~ 20	7.76
	52.636X.16.139	DAT50 x SAM16EX - 139.7	139.7	87	80	20 N-m	ER16	1 ~ 10	6.30
	52.636X.20.139	DAT50 x SAM20EX - 139.7	139.7	87	80	20 N-m	ER20	1 ~ 13	6.30
	52.636X.25.139	DAT50 x SAM25EX - 139.7	139.7	87	80	20 N-m	ER25	1 ~ 16	6.30
	52.636X.32.139	DAT50 x SAM32EX - 139.7	139.7	82	80	20 N-m	ER32	2 ~ 20	8.86
 <p>DIN 69893 A</p>	73.636X.16.145	HSK63A x SAM16EX - 145	145	87	65	20 N-m	ER16	1 ~ 10	6.40
	73.636X.20.145	HSK63A x SAM20EX - 145	145	87	65	20 N-m	ER20	1 ~ 13	6.40
	73.636X.25.145	HSK63A x SAM25EX - 145	145	87	65	20 N-m	ER25	1 ~ 16	6.40
	73.636X.32.145	HSK63A x SAM32EX - 145	145	82	65	20 N-m	ER32	2 ~ 20	6.44
	75.636X.16.150	HSK100A x SAM16EX - 150	150	87	80	20 N-m	ER16	1 ~ 10	8.40
	75.636X.20.150	HSK100A x SAM20EX - 150	150	87	80	20 N-m	ER20	1 ~ 13	8.40
	75.636X.25.150	HSK100A x SAM25EX - 150	150	87	80	20 N-m	ER25	1 ~ 16	8.40
	75.636X.32.150	HSK100A x SAM32EX - 150	150	82	80	20 N-m	ER32	2 ~ 20	8.44

Product information:

- ▶ Gear ratio 1:1. ▶ Max. revolution: 4000rpm. ▶ Max. torque: 20N-m. ▶ Suggested $A_p \leq 2$ mm.
- ▶ Internal coolant not available. ▶ Rotating direction opposite to machine spindle. ▶ Can be used for ATC.



Reminder:

- ▶ Fix blocks are necessary for installing angle head on the machine [P.5-35~36].
- ▶ Fix blocks are varied by different machine designs. Please confirm the detailed dimensions when ordering.

Optional Fixed Block



P.5-35~36



SAM ANGLE HEAD HOLDER

FOR LIGHT CUTTING

SAM 小鋼炮銑削頭

(ER TYPE)

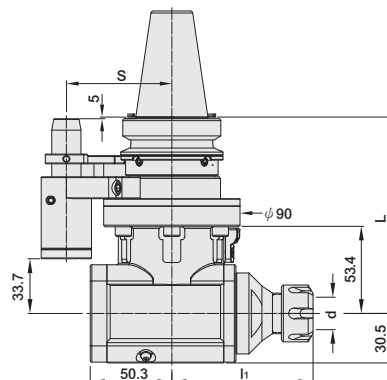

WITHOUT COOLANT SYSTEM

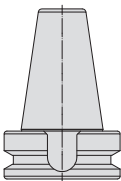
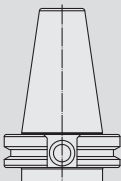
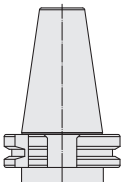
SHANK	MODEL NO.	TYPE	L	l ₁	S	TORQUE	COLLET	SIZE d RANGE	WEIGHT (KGS)
 DualDRIVE+	26.636X.16.120	SBT40 x SAM16EX - 120	120	87	65	20 N-m	ER16	1 ~ 10	5.20
	26.636X.20.120	SBT40 x SAM20EX - 120	120	87	65	20 N-m	ER20	1 ~ 13	5.20
	26.636X.25.120	SBT40 x SAM25EX - 120	120	87	65	20 N-m	ER25	1 ~ 16	5.20
	26.636X.32.120	SBT40 x SAM32EX - 120	120	82	65	20 N-m	ER32	2 ~ 20	7.76
	27.636X.16.130	SBT50 x SAM16EX - 130	130	87	80	20 N-m	ER16	1 ~ 10	6.30
	27.636X.20.130	SBT50 x SAM20EX - 130	130	87	80	20 N-m	ER20	1 ~ 13	6.30
	27.636X.25.130	SBT50 x SAM25EX - 130	130	87	80	20 N-m	ER25	1 ~ 16	6.30
 DualDRIVE+	27.636X.32.130	SBT50 x SAM32EX - 130	130	82	80	20 N-m	ER32	2 ~ 20	8.86
	43.636X.16.537	SCAT40 x SAM16EX - 5.372"	5.372	3.425	2.559	20 N-m	ER16	1 ~ 10	5.20
	43.636X.20.537	SCAT40 x SAM20EX - 5.372"	5.372	3.425	2.559	20 N-m	ER20	1 ~ 13	5.20
	43.636X.25.537	SCAT40 x SAM25EX - 5.372"	5.372	3.425	2.559	20 N-m	ER25	1 ~ 16	5.20
	43.636X.32.537	SCAT40 x SAM32EX - 5.372"	5.372	3.228	2.559	20 N-m	ER32	2 ~ 20	7.76
	44.636X.16.550	SCAT50 x SAM16EX - 5.5"	5.5	3.425	3.145	20 N-m	ER16	1 ~ 10	6.30
	44.636X.20.550	SCAT50 x SAM20EX - 5.5"	5.5	3.425	3.145	20 N-m	ER20	1 ~ 13	6.30
 DualDRIVE+	44.636X.25.550	SCAT50 x SAM25EX - 5.5"	5.5	3.425	3.145	20 N-m	ER25	1 ~ 16	6.30
	44.636X.32.550	SCAT50 x SAM32EX - 5.5"	5.5	3.228	3.145	20 N-m	ER32	2 ~ 20	8.86
	66.636X.16.136	SDAT40 x SAM16EX - 136.45	136.45	87	65	20 N-m	ER16	1 ~ 10	5.20
	66.636X.20.136	SDAT40 x SAM20EX - 136.45	136.45	87	65	20 N-m	ER20	1 ~ 13	5.20
	66.636X.25.136	SDAT40 x SAM25EX - 136.45	136.45	87	65	20 N-m	ER25	1 ~ 16	5.20
	66.636X.32.136	SDAT40 x SAM32EX - 136.45	136.45	82	65	20 N-m	ER32	2 ~ 20	7.76
	67.636X.16.139	SDAT50 x SAM16EX - 139.7	139.7	87	80	20 N-m	ER16	1 ~ 10	6.30
	67.636X.20.139	SDAT50 x SAM20EX - 139.7	139.7	87	80	20 N-m	ER20	1 ~ 13	6.30
	67.636X.25.139	SDAT50 x SAM25EX - 139.7	139.7	87	80	20 N-m	ER25	1 ~ 16	6.30
67.636X.32.139	SDAT50 x SAM32EX - 139.7	139.7	82	80	20 N-m	ER32	2 ~ 20	8.86	

Product information:

- ▶ Gear ratio 1:1.
- ▶ Max. revolution: 4000rpm.
- ▶ Max. torque: 20N-m.
- ▶ Suggested $A_p \leq 2\text{mm}$.
- ▶ Internal coolant not available.
- ▶ Rotating direction opposite to machine spindle.
- ▶ Can be used for ATC.



Reminder:

- ▶ Fix blocks are necessary for installing angle head on the machine [P.5-35~36].
- ▶ Fix blocks are varied by different machine designs. Please confirm the detailed dimensions when ordering.

Optional
Fixed Block



P.5-35~36



SAM ANGLE HEAD HOLDER

FOR LIGHT CUTTING

SAM 小鋼炮銑削頭

(SCA TYPE)

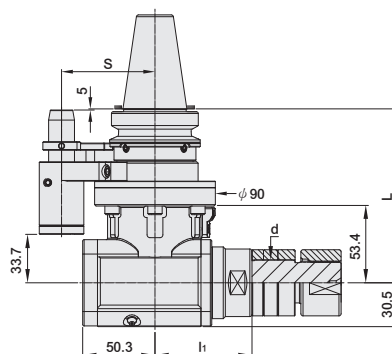

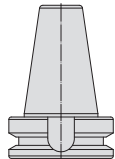
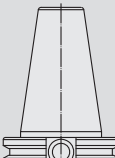
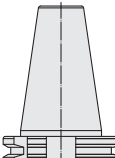
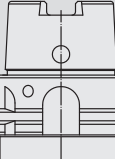
SHANK	MODEL NO.	TYPE	L	l ₁	S	TORQUE	d	WEIGHT (KGS)
 MAS 403	11.637.68.120	BT40 x SAM25.4SC - 120	120	67.5	65	20 N-m	25.4	6.40
	11.637.72.120	BT40 x SAM31.75SC - 120	120	67.5	65	20 N-m	31.75	6.40
	12.637.68.130	BT50 x SAM25.4SC - 130	130	67.5	80	20 N-m	25.4	6.44
	12.637.72.130	BT50 x SAM31.75SC - 130	130	67.5	80	20 N-m	31.75	6.44
 ANSI B5.50	31.637.68.537	CAT40 x SAM1"SC - 5.372"	5.372	67.5	2.559	20 N-m	1	6.40
	31.637.72.537	CAT40 x SAM1-1/4"SC - 5.372"	5.372	67.5	2.559	20 N-m	1-1/4	6.40
	32.637.68.550	CAT50 x SAM1"SC - 5.5"	5.5	67.5	3.145	20 N-m	1	6.44
	32.637.72.550	CAT50 x SAM1-1/4"SC - 5.5"	5.5	67.5	3.145	20 N-m	1-1/4	6.44
 DIN 69871-A	51.637.68.136	DAT40 x SAM25.4SC - 136.45	136.45	67.5	65	20 N-m	25.4	6.40
	51.637.72.136	DAT40 x SAM31.75SC - 136.45	136.45	67.5	65	20 N-m	31.75	6.40
	52.637.68.139	DAT50 x SAM25.4SC - 139.7	139.7	67.5	80	20 N-m	25.4	6.44
	52.637.72.139	DAT50 x SAM31.75SC - 139.7	139.7	67.5	80	20 N-m	31.75	6.44
 DIN 69893 A	73.637.68.145	HSK63A x SAM25.4SC - 145	145	67.5	65	20 N-m	25.4	8.40
	73.637.72.145	HSK63A x SAM31.75SC - 145	145	67.5	65	20 N-m	31.75	8.40
	75.637.68.150	HSK100A x SAM25.4SC - 150	150	67.5	80	20 N-m	25.4	8.40
	75.637.72.150	HSK100A x SAM31.75SC - 150	150	67.5	80	20 N-m	31.75	8.40

Product information:

- ▶ Gear ratio 1:1.
- ▶ Max. revolution: 4000rpm.
- ▶ Max. torque: 20N-m.
- ▶ Suggested $A_p \leq 2\text{mm}$.
- ▶ Coolant feed through spindle or dowel pin, coolant outlet from cutting tools or coolant nozzles.
- ▶ Max. water pressure: $7\text{kgf/cm}^2(100\text{PSI})$.
- ▶ Rotating direction opposite to machine spindle.
- ▶ Can be used for ATC.



Reminder:

- ▶ Fix blocks are necessary for installing angle head on the machine [P.5-35~36].
- ▶ Fix blocks are varied by different machine designs. Please confirm the detailed dimensions when ordering.

Optional
Fixed Block



P.5-35~36



SAM ANGLE HEAD HOLDER

FOR LIGHT CUTTING

SAM 小鋼炮銑削頭

[SCA TYPE]

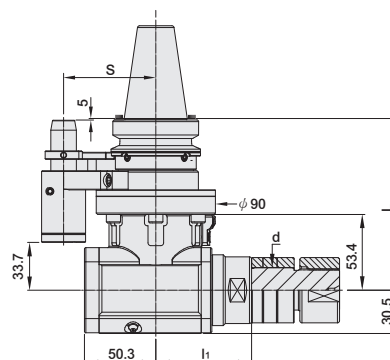

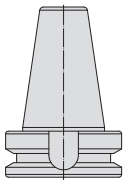
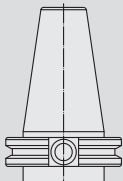
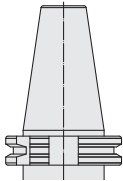
SHANK	MODEL NO.	TYPE	L	l ₁	S	TORQUE	d	WEIGHT (KGS)
 DualDRIVE+	26.637.68.120	SBT40 x SAM25.4SC - 120	120	67.5	65	20 N-m	25.4	6.40
	26.637.72.120	SBT40 x SAM31.75SC - 120	120	67.5	65	20 N-m	31.75	6.40
	27.637.68.130	SBT50 x SAM25.4SC - 130	130	67.5	80	20 N-m	25.4	6.44
	27.637.72.130	SBT50 x SAM31.75SC - 130	130	67.5	80	20 N-m	31.75	6.44
 DualDRIVE+	43.637.68.537	SCAT40 x SAM1"SC - 5.372"	5.372	67.5	2.559	20 N-m	1	6.40
	43.637.72.537	SCAT40 x SAM1-1/4"SC - 5.372"	5.372	67.5	2.559	20 N-m	1-1/4	6.40
	44.637.68.550	SCAT50 x SAM1"SC - 5.5"	5.5	67.5	3.145	20 N-m	1	6.44
	44.637.72.550	SCAT50 x SAM1-1/4"SC - 5.5"	5.5	67.5	3.145	20 N-m	1-1/4	6.44
 DualDRIVE+	66.637.68.136	SDAT40 x SAM25.4SC - 136.45	136.45	67.5	65	20 N-m	25.4	6.40
	66.637.72.136	SDAT40 x SAM31.75SC - 136.45	136.45	67.5	65	20 N-m	31.75	6.40
	67.637.68.139	SDAT50 x SAM25.4SC - 139.7	139.7	67.5	80	20 N-m	25.4	6.44
	67.637.72.139	SDAT50 x SAM31.75SC - 139.7	139.7	67.5	80	20 N-m	31.75	6.44

Product information:

- ▶ Gear ratio 1:1.
- ▶ Max. revolution: 4000rpm.
- ▶ Max. torque: 20N-m.
- ▶ Suggested $A_p \leq 2$ mm.
- ▶ Coolant feed through spindle or dowel pin, coolant outlet from cutting tools or coolant nozzles.
- ▶ Max. water pressure: 7kgf/cm²(100PSI).
- ▶ Rotating direction opposite to machine spindle.
- ▶ Can be used for ATC.



Reminder:

- ▶ Fix blocks are necessary for installing angle head on the machine [P.5-35~36].
- ▶ Fix blocks are varied by different machine designs. Please confirm the detailed dimensions when ordering.

Optional
Fixed Block



P.5-35~36



SAG ANGLE HEAD HOLDER

SLIM TYPE

SAG 小徑銑削頭

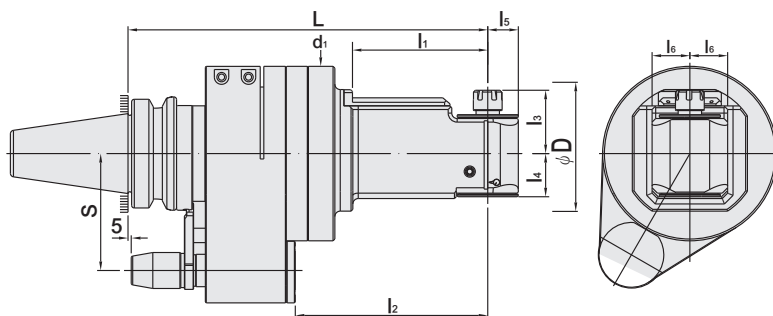

SHANK	MODEL NO.	TYPE	L	l ₁	l ₂	l ₃	l ₄	l ₅	l ₆	d ₁	φ D	S	TORQUE	COLLET	WEIGHT (KGS)
	11.676.11.170	BT40 x SAG11E - 170	170	45.2	77	39.2	24	17	21	97	72	65	10N-m	ER11	5.10
	11.676.11.200	BT40 x SAG11E - 200	200	75.2	107	39.2	24	17	21	97	72	65	10N-m	ER11	5.30
	11.676.11.230	BT40 x SAG11E - 230	230	105.2	137	39.2	24	17	21	97	72	65	10N-m	ER11	5.50
	11.676.11.260	BT40 x SAG11E - 260	260	135.2	167	39.2	24	17	21	97	72	65	10N-m	ER11	5.70
	11.676.16.170	BT40 x SAG16E - 170	170	38	77	57.1	45.3	28	31	99	120	65	20N-m	ER16	5.50
	11.676.16.200	BT40 x SAG16E - 200	200	82	107	57.1	45.3	28	31	99	120	65	20N-m	ER16	5.93
	11.676.16.230	BT40 x SAG16E - 230	230	112	137	57.1	45.3	28	31	99	120	65	20N-m	ER16	6.32
	11.676.16.260	BT40 x SAG16E - 260	260	142	167	57.1	45.3	28	31	99	120	65	20N-m	ER16	6.72
	11.676.20.170	BT40 x SAG20E - 170	170	38	77	58.5	45.3	28	31	99	120	65	20N-m	ER20	5.80
	11.676.20.200	BT40 x SAG20E - 200	200	82	107	58.5	45.3	28	31	99	120	65	20N-m	ER20	5.90
	11.676.20.230	BT40 x SAG20E - 230	230	112	137	58.5	45.3	28	31	99	120	65	20N-m	ER20	6.60
	11.676.20.260	BT40 x SAG20E - 260	260	142	167	58.5	45.3	28	31	99	120	65	20N-m	ER20	6.80
	12.676.16.185	BT50 x SAG16E - 185	185	38	77	57.1	45.3	28	31	99	120	80	20N-m	ER16	9.00
	12.676.16.215	BT50 x SAG16E - 215	215	82	107	57.1	45.3	28	31	99	120	80	20N-m	ER16	9.41
	12.676.16.245	BT50 x SAG16E - 245	245	112	137	57.1	45.3	28	31	99	120	80	20N-m	ER16	9.81
	12.676.16.275	BT50 x SAG16E - 275	275	142	167	57.1	45.3	28	31	99	120	80	20N-m	ER16	10.2
	12.676.20.185	BT50 x SAG20E - 185	185	38	77	58.5	45.3	28	31	99	120	80	20N-m	ER20	8.90
	12.676.20.215	BT50 x SAG20E - 215	215	82	107	58.5	45.3	28	31	99	120	80	20N-m	ER20	9.50
	12.676.20.245	BT50 x SAG20E - 245	245	112	137	58.5	45.3	28	31	99	120	80	20N-m	ER20	9.80
	12.676.20.275	BT50 x SAG20E - 275	275	142	167	58.5	45.3	28	31	99	120	80	20N-m	ER20	10.9

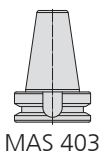

MAS 403

COLLET	SIZE RANGE
ER11	1 ~ 7
ER16	1 ~ 10
ER20	1 ~ 13

Product information:

- ▶ Gear ratio 1:1.
- ▶ Max. revolution: 6000rpm.
- ▶ Max. torque: 15N-m.
- ▶ Suggested $A_p \leq 2\text{mm}$.
- ▶ Coolant feed through dowel pin, coolant outlet from 2 coolant holes.
- ▶ Max. water pressure: $7\text{kgf/cm}^2(100\text{PSI})$.
- ▶ Rotating direction opposite to machine spindle.
- ▶ Can be used for ATC.



Reminder:

- ▶ Fix blocks are necessary for installing angle head on the machine [P.5-35~36].
- ▶ Fix blocks are varied by different machine designs. Please confirm the detailed dimensions when ordering.

Optional
Fixed Block



P.5-35~36



SAG ANGLE HEAD HOLDER

SLIM TYPE

SAG 小徑銑削頭

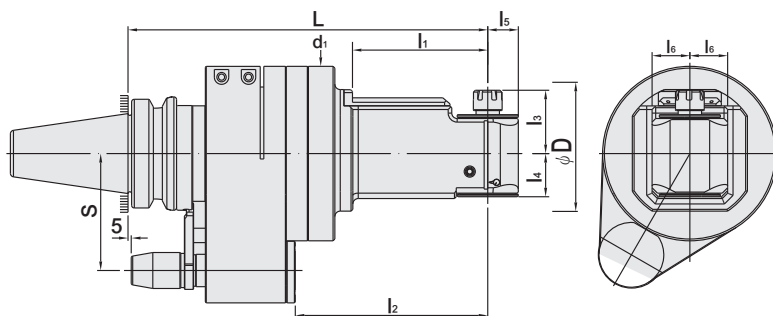

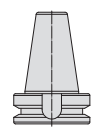
SHANK	MODEL NO.	TYPE	L	l ₁	l ₂	l ₃	l ₄	l ₅	l ₆	d ₁	φD	S	TORQUE	COLLET	WEIGHT (KGS)
 MAS 403	11.676.06S.170	BT40 x SAG6S - 170	170	45.2	77	42	24	17	21	97	85	65	10N-m	SKS6	4.80
	11.676.06S.200	BT40 x SAG6S - 200	200	75.2	107	42	24	17	21	97	85	65	10N-m	SKS6	5.10
	11.676.06S.230	BT40 x SAG6S - 230	230	105.2	137	42	24	17	21	97	85	65	10N-m	SKS6	5.30
	11.676.06S.260	BT40 x SAG6S - 260	260	135.2	167	42	24	17	21	97	85	65	10N-m	SKS6	5.52
	11.676.13S.170	BT40 x SAG13S - 170	170	38	77	55.8	45.3	28	31	99	116	65	20N-m	SKS13	5.55
	11.676.13S.200	BT40 x SAG13S - 200	200	82	107	55.8	45.3	28	31	99	116	65	20N-m	SKS13	6.10
	11.676.13S.230	BT40 x SAG13S - 230	230	112	137	55.8	45.3	28	31	99	116	65	20N-m	SKS13	6.36
	11.676.13S.260	BT40 x SAG13S - 260	260	142	167	55.8	45.3	28	31	99	116	65	20N-m	SKS13	6.76
	12.676.13S.185	BT50 x SAG13S - 185	185	38	77	55.8	45.3	28	31	99	116	80	20N-m	SKS13	9.10
	12.676.13S.215	BT50 x SAG13S - 215	215	82	107	55.8	45.3	28	31	99	116	80	20N-m	SKS13	9.45
	12.676.13S.245	BT50 x SAG13S - 245	245	112	137	55.8	45.3	28	31	99	116	80	20N-m	SKS13	9.84
	12.676.13S.275	BT50 x SAG13S - 275	275	142	167	55.8	45.3	28	31	99	116	80	20N-m	SKS13	10.3
COLLET	SIZE RANGE														
SKS6	3 ~ 6														
SKS13	3 ~ 13														

Product information:

- ▶ Gear ratio 1:1.
- ▶ Max. revolution: 6000rpm.
- ▶ Max. torque: 15N-m.
- ▶ Suggested $A_p \leq 2\text{mm}$.
- ▶ Coolant feed through dowel pin, coolant outlet from 2 coolant holes.
- ▶ Max. water pressure: 7kgf/cm^2 (100PSI).
- ▶ Rotating direction opposite to machine spindle.
- ▶ Can be used for ATC.



Reminder:

- ▶ Fix blocks are necessary for installing angle head on the machine [P.5-35~36].
- ▶ Fix blocks are varied by different machine designs. Please confirm the detailed dimensions when ordering.

Optional Fixed Block



P.5-35~36



SAG ANGLE HEAD HOLDER

SLIM TYPE

SAG 小徑銑削頭

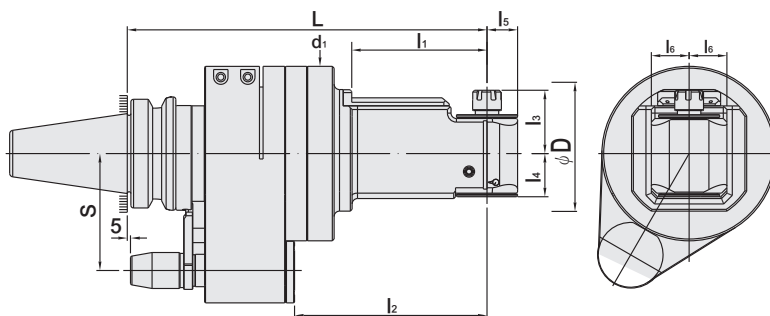

SHANK	MODEL NO.	TYPE	L	l ₁	l ₂	l ₃	l ₄	l ₅	l ₆	d ₁	φ D	S	TORQUE	COLLET	WEIGHT (KGS)
DauDRIVE+	26.676.11.170	SBT40 x SAG11E - 170	170	45.2	77	39.2	24	17	21	97	72	65	10N-m	ER11	5.10
	26.676.11.200	SBT40 x SAG11E - 200	200	75.2	107	39.2	24	17	21	97	72	65	10N-m	ER11	5.30
	26.676.11.230	SBT40 x SAG11E - 230	230	105.2	137	39.2	24	17	21	97	72	65	10N-m	ER11	5.50
	26.676.11.260	SBT40 x SAG11E - 260	260	135.2	167	39.2	24	17	21	97	72	65	10N-m	ER11	5.70
	26.676.16.170	SBT40 x SAG16E - 170	170	38	77	57.1	45.3	28	31	99	120	65	20N-m	ER16	5.50
	26.676.16.200	SBT40 x SAG16E - 200	200	82	107	57.1	45.3	28	31	99	120	65	20N-m	ER16	5.93
	26.676.16.230	SBT40 x SAG16E - 230	230	112	137	57.1	45.3	28	31	99	120	65	20N-m	ER16	6.32
	26.676.16.260	SBT40 x SAG16E - 260	260	142	167	57.1	45.3	28	31	99	120	65	20N-m	ER16	6.72
	26.676.20.170	SBT40 x SAG20E - 170	170	38	77	58.5	45.3	28	31	99	120	65	20N-m	ER20	5.80
	26.676.20.200	SBT40 x SAG20E - 200	200	82	107	58.5	45.3	28	31	99	120	65	20N-m	ER20	5.90
	26.676.20.230	SBT40 x SAG20E - 230	230	112	137	58.5	45.3	28	31	99	120	65	20N-m	ER20	6.60
	26.676.20.260	SBT40 x SAG20E - 260	260	142	167	58.5	45.3	28	31	99	120	65	20N-m	ER20	6.80
	27.676.16.185	SBT50 x SAG16E - 185	185	38	77	57.1	45.3	28	31	99	120	80	20N-m	ER16	9.00
	27.676.16.215	SBT50 x SAG16E - 215	215	82	107	57.1	45.3	28	31	99	120	80	20N-m	ER16	9.41
	27.676.16.245	SBT50 x SAG16E - 245	245	112	137	57.1	45.3	28	31	99	120	80	20N-m	ER16	9.81
	27.676.16.275	SBT50 x SAG16E - 275	275	142	167	57.1	45.3	28	31	99	120	80	20N-m	ER16	10.2
	27.676.20.185	SBT50 x SAG20E - 185	185	38	77	58.5	45.3	28	31	99	120	80	20N-m	ER20	8.90
	27.676.20.215	SBT50 x SAG20E - 215	215	82	107	58.5	45.3	28	31	99	120	80	20N-m	ER20	9.50
	27.676.20.245	SBT50 x SAG20E - 245	245	112	137	58.5	45.3	28	31	99	120	80	20N-m	ER20	9.80
	27.676.20.275	SBT50 x SAG20E - 275	275	142	167	58.5	45.3	28	31	99	120	80	20N-m	ER20	10.9



DauDRIVE+

COLLET	SIZE RANGE
ER11	1 ~ 7
ER16	1 ~ 10
ER20	1 ~ 13

Product information:

- ▶ Gear ratio 1:1.
- ▶ Max. revolution: 6000rpm.
- ▶ Max. torque: 15N-m.
- ▶ Suggested $A_p \leq 2\text{mm}$.
- ▶ Coolant feed through dowel pin, coolant outlet from 2 coolant holes.
- ▶ Max. water pressure: $7\text{kgf/cm}^2(100\text{PSI})$.
- ▶ Rotating direction opposite to machine spindle.
- ▶ Can be used for ATC.



Reminder:

- ▶ Fix blocks are necessary for installing angle head on the machine [P.5-35~36].
- ▶ Fix blocks are varied by different machine designs. Please confirm the detailed dimensions when ordering.

Optional
Fixed Block



P.5-35~36



SAG ANGLE HEAD HOLDER

SLIM TYPE

SAG 小徑銑削頭

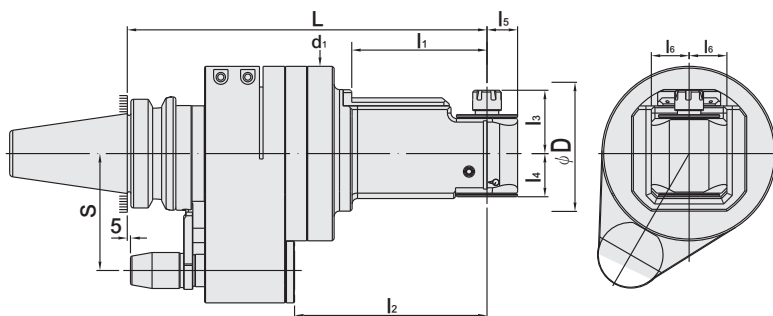

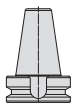
SHANK	MODEL NO.	TYPE	L	l ₁	l ₂	l ₃	l ₄	l ₅	l ₆	d ₁	φD	S	TORQUE	COLLET	WEIGHT (KGS)
 DaulDRIVE+	26.676.06S.170	SBT40 x SAG6S - 170	170	45.2	77	42	24	17	21	97	85	65	10N-m	SKS6	4.80
	26.676.06S.200	SBT40 x SAG6S - 200	200	75.2	107	42	24	17	21	97	85	65	10N-m	SKS6	5.10
	26.676.06S.230	SBT40 x SAG6S - 230	230	105.2	137	42	24	17	21	97	85	65	10N-m	SKS6	5.30
	26.676.06S.260	SBT40 x SAG6S - 260	260	135.2	167	42	24	17	21	97	85	65	10N-m	SKS6	5.52
	26.676.13S.170	SBT40 x SAG13S - 170	170	38	77	55.8	45.3	28	31	99	116	65	20N-m	SKS13	5.55
	26.676.13S.200	SBT40 x SAG13S - 200	200	82	107	55.8	45.3	28	31	99	116	65	20N-m	SKS13	6.10
	26.676.13S.230	SBT40 x SAG13S - 230	230	112	137	55.8	45.3	28	31	99	116	65	20N-m	SKS13	6.36
	26.676.13S.260	SBT40 x SAG13S - 260	260	142	167	55.8	45.3	28	31	99	116	65	20N-m	SKS13	6.76
	27.676.13S.185	SBT50 x SAG13S - 185	185	38	77	55.8	45.3	28	31	99	116	80	20N-m	SKS13	9.10
	27.676.13S.215	SBT50 x SAG13S - 215	215	82	107	55.8	45.3	28	31	99	116	80	20N-m	SKS13	9.45
	27.676.13S.245	SBT50 x SAG13S - 245	245	112	137	55.8	45.3	28	31	99	116	80	20N-m	SKS13	9.84
	27.676.13S.275	SBT50 x SAG13S - 275	275	142	167	55.8	45.3	28	31	99	116	80	20N-m	SKS13	10.3
COLLET	SIZE RANGE														
SKS6	3 ~ 6														
SKS13	3 ~ 13														

Product information:

- ▶ Gear ratio 1:1.
- ▶ Max. revolution: 6000rpm.
- ▶ Max. torque: 15N-m.
- ▶ Suggested $A_p \leq 2\text{mm}$.
- ▶ Coolant feed through dowel pin, coolant outlet from 2 coolant holes.
- ▶ Max. water pressure: 7kgf/cm^2 (100PSI).
- ▶ Rotating direction opposite to machine spindle.
- ▶ Can be used for ATC.



Reminder:

- ▶ Fix blocks are necessary for installing angle head on the machine [P.5-35~36].
- ▶ Fix blocks are varied by different machine designs. Please confirm the detailed dimensions when ordering.

**Optional
Fixed Block**



P.5-35~36



SAG ANGLE HEAD HOLDER

SLIM TYPE

SAG 小徑銑削頭

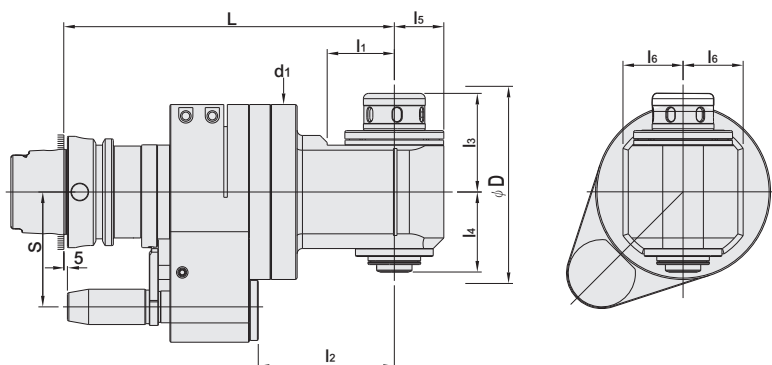

SHANK	MODEL NO.	TYPE	L	l ₁	l ₂	l ₃	l ₄	l ₅	l ₆	d ₁	φ D	S	TORQUE	COLLET	WEIGHT (KGS)
	73.676.11E.185	HSK63A x SAG11E - 185	185	45.2	77	39.2	24	17	21	72	97	65	10N-m	ER11	5.52
	73.676.11E.215	HSK63A x SAG11E - 215	215	75.2	107	39.2	24	17	21	72	97	65	10N-m	ER11	5.95
	73.676.11E.245	HSK63A x SAG11E - 245	245	105.2	137	39.2	24	17	21	72	97	65	10N-m	ER11	6.35
	73.676.11E.275	HSK63A x SAG11E - 275	275	135.2	167	39.2	24	17	21	72	97	65	10N-m	ER11	6.73
	73.676.16.185	HSK63A x SAG16E - 185	185	38	77	57.1	45.3	17	21	97	120	65	20N-m	ER16	5.50
	73.676.16.215	HSK63A x SAG16E - 215	215	82	107	57.1	45.3	17	21	97	120	65	20N-m	ER16	5.93
	73.676.16.245	HSK63A x SAG16E - 245	245	112	137	57.1	45.3	17	21	97	120	65	20N-m	ER16	6.32
	73.676.16.275	HSK63A x SAG16E - 275	275	142	167	57.1	45.3	17	21	97	120	65	20N-m	ER16	6.72
	73.676.20.185	HSK63A x SAG20E - 185	185	38	77	58.5	45.3	17	21	97	120	65	20N-m	ER20	5.37
	73.676.20.215	HSK63A x SAG20E - 215	215	82	107	58.5	45.3	17	21	97	120	65	20N-m	ER20	5.81
	73.676.20.245	HSK63A x SAG20E - 245	245	112	137	58.5	45.3	17	21	97	120	65	20N-m	ER20	6.21
	73.676.20.275	HSK63A x SAG20E - 275	275	142	167	58.5	45.3	17	21	97	120	65	20N-m	ER20	6.60
	73.676.06S.185	HSK63A x SAG6S - 185	185	45.2	77	42	24	17	21	85	97	65	10N-m	SKS6	5.55
	73.676.06S.215	HSK63A x SAG6S - 215	215	75.2	107	42	24	17	21	85	97	65	10N-m	SKS6	6.10
	73.676.06S.245	HSK63A x SAG6S - 245	245	105.2	137	42	24	17	21	85	97	65	10N-m	SKS6	6.36
	73.676.06S.275	HSK63A x SAG6S - 275	275	135.2	167	42	24	17	21	85	97	65	10N-m	SKS6	6.76
	73.676.13S.185	HSK63A x SAG13S - 185	185	38	77	55.8	45.3	17	21	97	116	65	20N-m	SKS13	5.52
	73.676.13S.215	HSK63A x SAG13S - 215	215	82	107	55.8	45.3	17	21	97	116	65	20N-m	SKS13	5.95
	73.676.13S.245	HSK63A x SAG13S - 245	245	112	137	55.8	45.3	17	21	97	116	65	20N-m	SKS13	6.35
	73.676.13S.275	HSK63A x SAG13S - 275	275	142	167	55.8	45.3	17	21	97	116	65	20N-m	SKS13	6.73

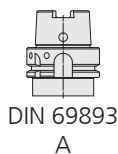

COLLET	SIZE RANGE
ER11	1 ~ 7
ER16	1 ~ 10
ER20	1 ~ 13
SKS6	3 ~ 6
SKS13	3 ~ 13

Product information:

- ▶ Gear ratio 1:1. ▶ Max. revolution: 6000rpm. ▶ Max. torque: 15N-m.
- ▶ Suggested $A_p \leq 2\text{mm}$. ▶ Coolant feed through dowel pin, coolant outlet from 2 coolant holes.
- ▶ Max. water pressure: 7kgf/cm^2 (100PSI). ▶ Rotating direction opposite to machine spindle.
- ▶ Can be used for ATC.



Reminder:

- ▶ Fix blocks are necessary for installing angle head on the machine [P.5-35~36].
- ▶ Fix blocks are varied by different machine designs. Please confirm the detailed dimensions when ordering.

Optional
Fixed Block



P.5-35~36





SAD ANGLE HEAD HOLDER

SLIM TYPE

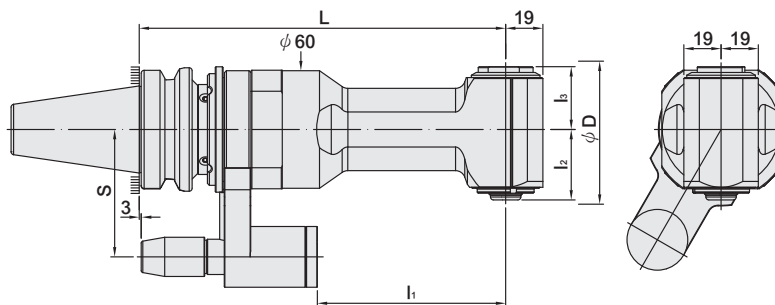
SAD 小徑銑削頭

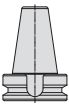

SHANK	MODEL NO.	TYPE	L	l ₁	l ₂	l ₃	φD	S	TORQUE	COLLET	SIZE RANGE	WEIGHT (KGS)
 DaulDRIVE+	25.791.08B.130	SBT30 x SAD8B - 130	130	74.6	36	32.5	76	55	10N-m	EBL8	3~8	2.60
	25.791.08B.182	SBT30 x SAD8B - 182	182	96.1	36	32.5	76	55	10N-m	EBL8	3~8	3.00
	26.791.08B.135	SBT40 x SAD8B - 135	135	74.6	36	32.5	76	65	10N-m	EBL8	3~8	3.40
	26.791.08B.187	SBT40 x SAD8B - 187	187	96.1	36	32.5	76	65	10N-m	EBL8	3~8	3.70
	25.791.10S.130	SBT30 x SAD10S - 130	130	74.6	34	54.5	115	55	10N-m	SKS10	3~10	2.66
	25.791.10S.182	SBT30 x SAD10S - 182	182	96.1	34	54.5	115	55	10N-m	SKS10	3~10	3.10
	26.791.10S.135	SBT40 x SAD10S - 135	135	74.6	34	54.5	115	65	10N-m	SKS10	3~10	3.50
	26.791.10S.187	SBT40 x SAD10S - 187	187	96.1	34	54.5	115	65	10N-m	SKS10	3~10	3.75
 DIN 69893 A	73.791.08B.195	HSK63A x SAD8B - 195	195	74.6	36	32.5	76	65	10N-m	EBL8	3~8	3.50
	73.791.10S.195	HSK63A x SAD10S - 195	195	96.1	34	54.5	115	65	10N-m	SKS10	3~10	3.80

Product information:

- ▶ Max. revolution: 6000rpm.
- ▶ Max. torque: 10N-m.
- ▶ Suggested $A_p \leq 1.5\text{mm}$.
- ▶ Slim design, for deep hole machining.
- ▶ For drilling, tapping & light milling.
- ▶ For tapping centers.
- ▶ Internal coolant not available.
- ▶ Rotating direction opposite to machine spindle.
- ▶ Can be used for ATC.



Reminder:

- ▶ Fix blocks are necessary for installing angle head on the machine [P.5-35~36].
- ▶ Fix blocks are varied by different machine designs. Please confirm the detailed dimensions when ordering.

Optional Fixed Block



P.5-35~36



CUTTING CONDITIONS

切削數據

Drilling

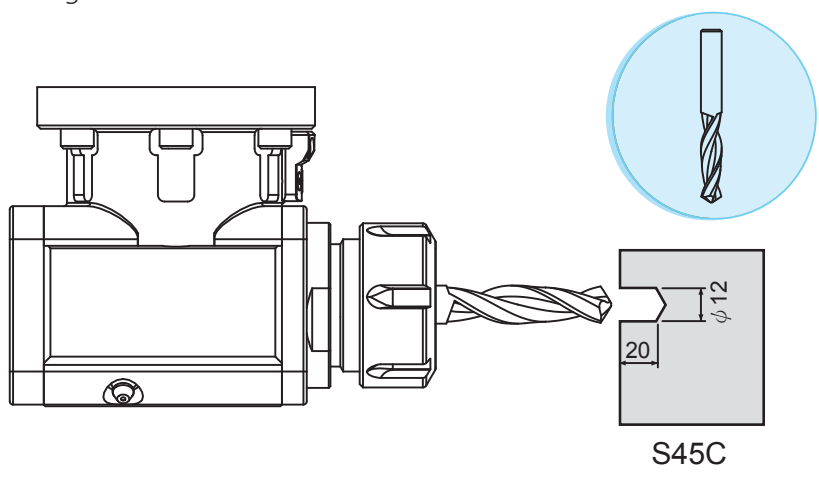

SAC	N: 1100 min ⁻¹ F: 120 mm/min V: 35.5 m/min Max. Torque: 25 N-m
SAM	N: 670 min ⁻¹ F: 80 mm/min V: 25.5 m/min Max. Torque: 20 N-m

Milling

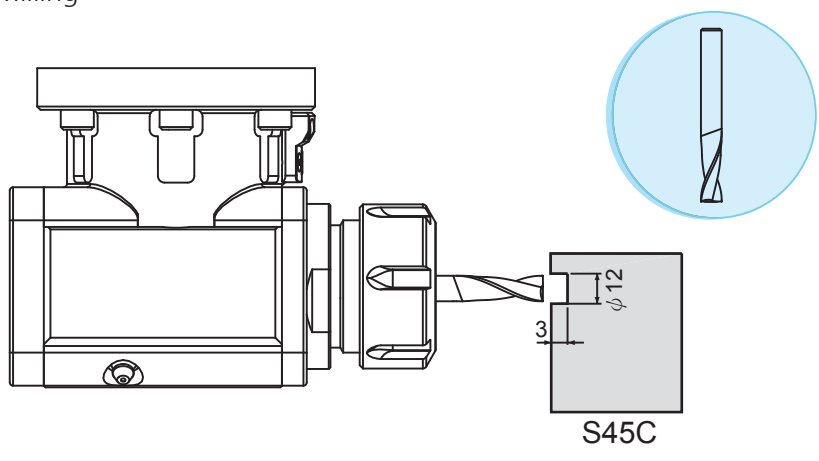

SAC	N: 500 min ⁻¹ F: 150 mm/min V: 18.8 m/min Max. Torque: 20 N-m
-----	---

Tapping

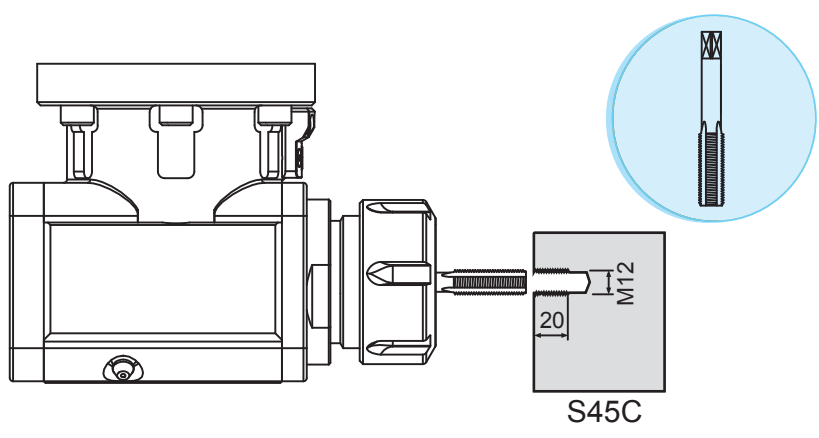

SAC	N: 200 min ⁻¹ F: 350 mm/min V: 7.53 m/min Max. Torque: 25 N-m
SAM	N: 200 min ⁻¹ F: 350 mm/min V: 7.53 m/min Max. Torque: 20 N-m



FIXED BLOCK

ONE PIECE TYPE

定位塊

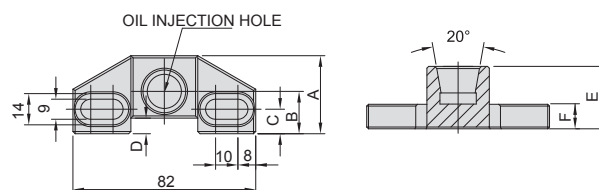

MODEL NO.	TYPE	NAME	A	B	C	D	E	F	WEIGHT (KGS)
350.673.40	SFT - 40	#40 FIXED BLOCK (Taper Type)	40	18.5	10	5	30	13	0.30
350.673.50	SFT - 50	#50 FIXED BLOCK (Taper Type)	34	19	11	7	35	15	0.32

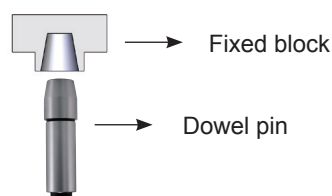

Features:

- ▶ Fixed block must be purchased according to the type of fixed pin.
- ▶ Fixed block can be installed on the spindle but must be fixed on the machine well. Otherwise, it is a threat for ATC tool change arm. Installation way changes with different machines. Please confirm with your machine supplier about correct installation way.



FIXED BLOCK

COMBINATION TYPE

組合式定位塊

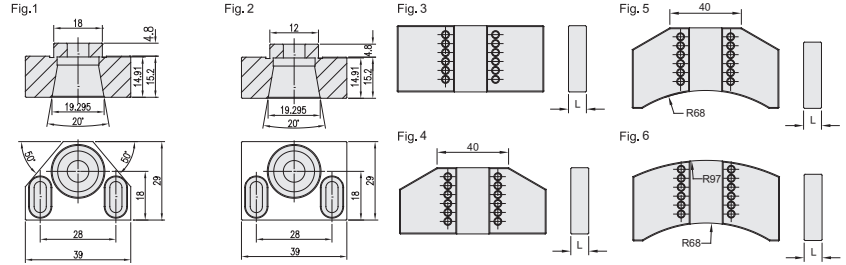

T W PAT NO. M417219
CN PAT NO. ZL201110289100.2

	TYPE	UPPER SEAT		BOTTOM SEAT		
		TYPE	Fig.	TYPE	Fig.	L
SFO-A-1-10	SFO-A	1	1	SFO-1-10	3	10
SFO-A-1-15	SFO-A	1	1	SFO-1-15	3	15
SFO-A-2-10	SFO-A	1	1	SFO-2-10	4	10
SFO-A-2-15	SFO-A	1	1	SFO-2-15	4	15
SFO-A-3-10	SFO-A	1	1	SFO-3-10	5	10
SFO-A-3-15	SFO-A	1	1	SFO-3-15	5	15
SFO-A-4-10	SFO-A	1	1	SFO-4-10	6	10
SFO-A-4-15	SFO-A	1	1	SFO-4-15	6	15
SFO-B-1-10	SFO-B	2	2	SFO-1-10	3	10
SFO-B-1-15	SFO-B	2	2	SFO-1-15	3	15
SFO-B-2-10	SFO-B	2	2	SFO-2-10	4	10
SFO-B-2-15	SFO-B	2	2	SFO-2-15	4	15
SFO-B-3-10	SFO-B	2	2	SFO-3-10	5	10
SFO-B-3-15	SFO-B	2	2	SFO-3-15	5	15
SFO-B-4-10	SFO-B	2	2	SFO-4-10	6	10
SFO-B-4-15	SFO-B	2	2	SFO-4-15	6	15

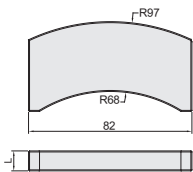
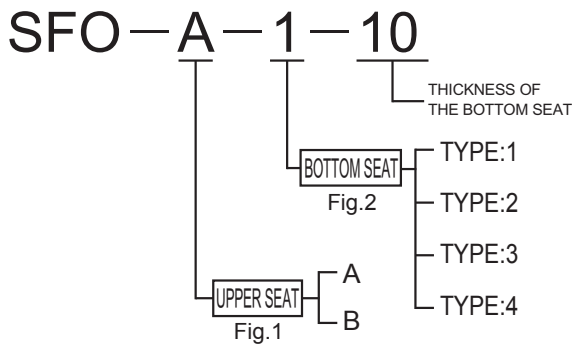

TYPE	L	TYPE	L
SFD-4-5	5	SFD-4-20	20
SFD-4-10	10	SFD-4-25	25
SFD-4-15	15		

Product information:

► If the height of the fixed block needs to be added, adjustable pads need to be purchased additionally.



REFERENCE DRAWING OF SPINDLE FIXED BLOCK

主軸定位塊參考圖

- ▶ When ordering custom-made products, please notice the distance variation between the spindle center and fixed block center hole, as well as indicate the size and position of fixed screw hole on your machine spindle flange.
- ▶ Before placing purchase order, please offer the related dimensions in detail by filling out the form and you could contact us via e-mail, telephone or fax.

TYPE ONE:

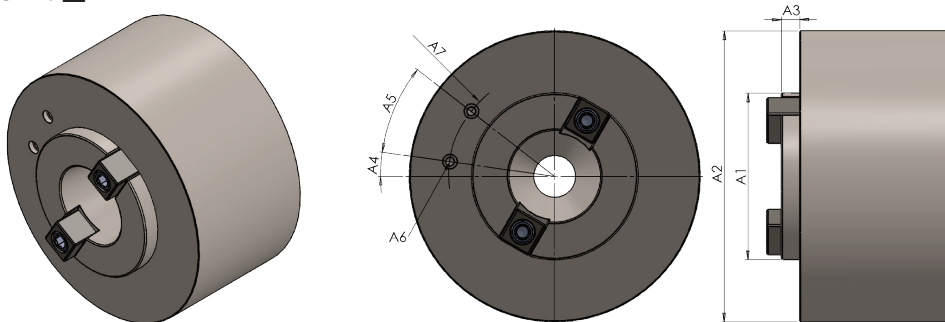

TYPE TWO:

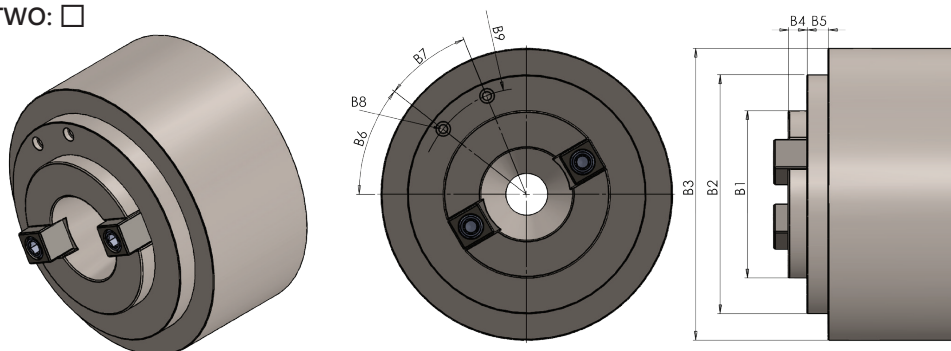

UNIT: mm

TYPE ONE: <input type="checkbox"/>				TYPE TWO: <input type="checkbox"/>			
The brand of machine				The brand of machine			
The model of machine				The model of machine			
A1		A5		B1		B6	
A2		A6		B2		B7	
A3		A7		B3		B8	
A4		S		B4		B9	
				B5		S	



▶ "S" is the distance between the center of the pin to center of the spindle.

