

HSK

CATEGORY

DIN 69893

A TYPE

PRO-E COLLET CHUCK	G-3~7
UT COLLET CHUCK	G-8
ER COLLET CHUCK	G-9~11
SKX COLLET CHUCK	G-12~14
SK3 COLLET CHUCK	G-15
USC ULTIMATE SIDE CLAMPING CHUCK	G-16~18
SBL SLIM-FIT COLLET CHUCK	G-19
SBLC SLIM-FIT COLLET CHUCK	G-20
EBL SLIM-FIT COLLET CHUCK	G-21
EBLC SLIM-FIT COLLET CHUCK	G-22
HBL SLIM-FIT COLLET CHUCK	G-23
SMG NON-PULLOUT MILLING CHUCK	G-24
MLD MULTI - LOCK MILLING CHUCK	G-25~26
EOC COLLET CHUCK	G-27
SAF RUNOUT ADJUSTABLE HOLDER	G-28~32
SBF RADIAL ZERO ADJUSTABLE HOLDER	G-33~34
SLN SIDE LOCK END MILL HOLDER	G-35~37
SLN SIDE LOCK END MILL HOLDER [JIS TYPE]	G-38
SLN SIDE LOCK END MILL HOLDER [FID TYPE]	G-39~40
SLN SIDE LOCK END MILL HOLDER [JIS-FID TYPE]	G-41
SLNB SIDE LOCK END MILL HOLDER	G-42
FACE MILL ARBOR [FMB TYPE]	G-43~45
FACE MILL ARBOR [FMC TYPE]	G-46
STA SYNCHRONIZED TAPPING HOLDER	G-47~48
QTC QUICK CHANGE TAPPING CHUCK	G-49
COMBI SHELL END MILL ARBOR	G-50
SPH DRILL CHUCK ADAPTER	G-51
SPU DRILL CHUCK ADAPTER	G-52
SOM SCREWED END MILL HOLDER	G-53
MORSE TAPER ADAPTER	G-54
HSK / PSC ADAPTER	G-55
BLANK	G-56

E TYPE

PRO-E COLLET CHUCK	G-58
ER COLLET CHUCK	G-59
SKX COLLET CHUCK	G-60
SK3 COLLET CHUCK	G-61
SBL SLIM-FIT COLLET CHUCK	G-62
SBLC SLIM-FIT COLLET CHUCK	G-63
BLANK	G-64

F TYPE

PRO-E COLLET CHUCK	G-66
ER COLLET CHUCK	G-67~68
SKX COLLET CHUCK	G-69
BLANK	G-70

T TYPE

EXTERNAL TURNING TOOL	G-73~83
SIDE LOCK HOLDER	G-84~85
EXTERNAL TURNING TOOL HOLDER	G-85~87
BLANK	G-88

REFERENCE DETAILS

DIN 69893 - 1

- ▶ Shank body standard : **DIN 69893-1**
- ▶ Taper tolerance < **AT3**
- ▶ Hardness > **HRC 56°**
- ▶ Surface roughness: Ra < **0.25 μm**
- ▶ Roundness < **0.6 μm**
- ▶ Carbon depth > **0.8mm**
- ▶ The shank has pre-balance at G6.3, and can provide precision balance at G2.5. It can be ordered by request.

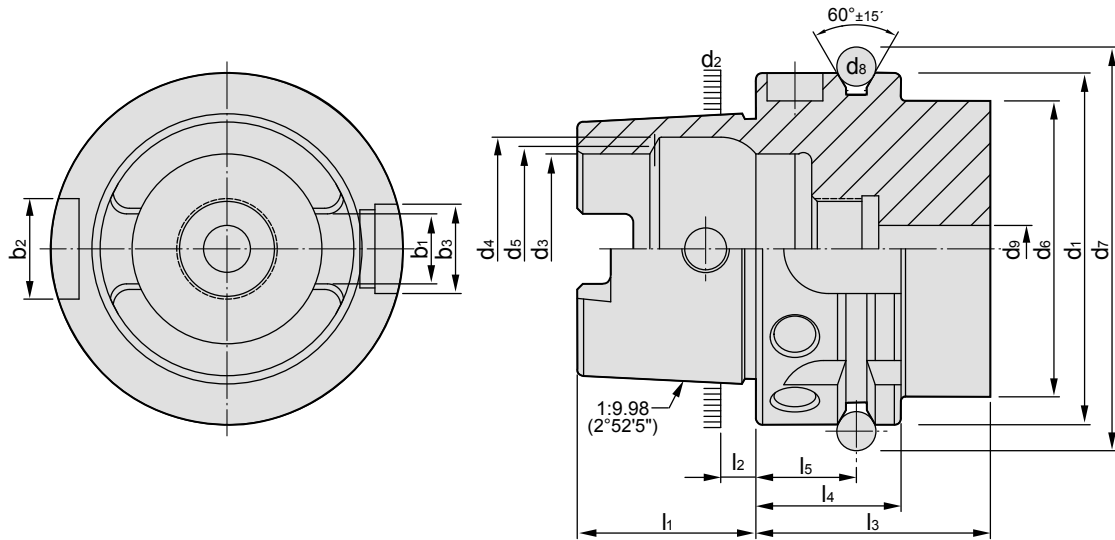

HSK	d ₁ h ₁₀	d ₂	d ₃ H ₁₀	d ₄ H ₁₁	d ₅	d ₆ max.	d ₇ 0 -0.1	d ₈	d ₉ max.
25	25	19.006	14	16.4	15	20	28.5	3	3
32	32	24.007	17	20.5	19	26	37	4	4.2
40	40	30.007	21	25.5	23	34	45	4	5
50	50	38.009	26	32	29	42	59.3	7	6.8
63	63	48.010	34	40	37	53	72.3	7	8.4
80	80	60.012	42	50	46	68	88.8	7	10.2
100	100	75.013	53	63	58	88	109.75	7	12
125	125	95.016	67	80	73	111	134.75	7	14
HSK	l ₁ 0 -0.2	l ₂	l ₃ min.	l ₄ 0 -0.1	l ₅ ±0.1	b ₁ ±0.04	b ₂ H ₁₀	b ₃ H ₁₀	
25	13	2.5	20	10	4.5	6.05	6	7	
32	16	3.2	35	20	16	7.05	7	9	
40	20	4	35	20	16	8.05	9	11	
50	25	5	42	26	18	10.54	12	14	
63	32	6.3	42	26	18	12.54	16	18	
80	40	8	42	26	18	16.04	18	20	
100	50	10	45	29	20	20.02	20	22	
125	63	12.5	45	29	20	25.02	25	28	

HSK / PRO-E COLLET CHUCK



HSK / PRO-E 筒夾式刀桿

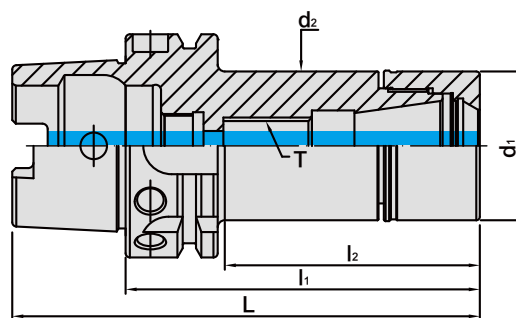

MODEL NO.	TYPE	L	l ₁	l ₂	d ₁	d ₂	T	SIZE RANGE	WEIGHT (KGS)
5071-529-016-070	HSK40A x PRO-E16 - 70	90	70	48	30	30	-	1 ~ 10	0.40
5071-529-016-100	HSK40A x PRO-E16 - 100	120	100	78	30	30	M10 x 1.5P	1 ~ 10	0.55
5071-529-020-070	HSK40A x PRO-E20 - 70	90	70	49	35	33.5	-	1 ~ 13	0.47
5071-529-020-100	HSK40A x PRO-E20 - 100	120	100	79	35	33.5	M12 x 1.75P	1 ~ 13	0.63
5071-529-025-070	HSK40A x PRO-E25 - 70	90	70	35	42	42	-	1 ~ 16	0.51
5071-529-025-100	HSK40A x PRO-E25 - 100	120	100	65	42	42	M16 x 2.0P	1 ~ 16	0.80
5071-529-032-070	HSK40A x PRO-E32 - 70	90	70	35	50	50	-	2 ~ 20	0.56
5071-529-032-100	HSK40A x PRO-E32 - 100	120	100	65	50	50	M16 x 2.0P	2 ~ 20	0.98
5072-529-016-070	HSK50A x PRO-E16 - 70	95	70	42	30	30	-	1 ~ 10	0.56
5072-529-016-100	HSK50A x PRO-E16 - 100	125	100	71	30	30	M10 x 1.5P	1 ~ 10	0.71
5072-529-016-125	HSK50A x PRO-E16 - 125	150	125	96	30	30	M10 x 1.5P	1 ~ 10	0.84
5072-529-016-150	HSK50A x PRO-E16 - 150	175	150	121	30	30	M10 x 1.5P	1 ~ 10	0.97
5072-529-020-070	HSK50A x PRO-E20 - 70	95	70	42	35	35	-	1 ~ 13	0.62
5072-529-020-100	HSK50A x PRO-E20 - 100	125	100	71	35	35	M12 x 1.75P	1 ~ 13	0.83
5072-529-020-125	HSK50A x PRO-E20 - 125	150	125	96	35	35	M12 x 1.75P	1 ~ 13	1.01
5072-529-020-150	HSK50A x PRO-E20 - 150	175	150	121	35	35	M12 x 1.75P	1 ~ 13	1.19
5072-529-025-070	HSK50A x PRO-E25 - 70	95	70	43.5	42	42	-	1 ~ 16	0.71
5072-529-025-100	HSK50A x PRO-E25 - 100	125	100	73.5	42	42	M16 x 2.0P	1 ~ 16	1.00
5072-529-025-125	HSK50A x PRO-E25 - 125	150	125	98.5	42	42	M16 x 2.0P	1 ~ 16	1.26
5072-529-025-150	HSK50A x PRO-E25 - 150	175	150	123.5	42	42	M16 x 2.0P	1 ~ 16	1.52
5072-529-032-080	HSK50A x PRO-E32 - 80	105	80	53	50	50	-	2 ~ 20	0.85
5072-529-032-100	HSK50A x PRO-E32 - 100	125	100	73	50	50	M16 x 2.0P	2 ~ 20	1.11
5072-529-032-125	HSK50A x PRO-E32 - 125	150	125	98	50	50	M16 x 2.0P	2 ~ 20	1.47
5072-529-032-150	HSK50A x PRO-E32 - 150	175	150	123	50	50	M16 x 2.0P	2 ~ 20	1.84

Features:

- ▶ Superior interchangeability with ER collets.
- ▶ Assembled with ER spring collet (15µm, 10µm, 5µm), ERS metallic sealed collet (10µm, 7µm, 5µm, 3µm) and ERS coolant FOD collet (10µm, 7µm, 5µm, 3µm).
- ▶ The design of enlarged holder ID hole optimizes the coverage of ER collet, shortens the tool overhanging length, and improves runout accuracy and machining stability.
- ▶ The design of straight parts above and below the thread makes PRO-E tool holders have better contact with clamping nuts to achieve higher runout accuracy.
- ▶ PRO-E nuts without slots reduce the wind shear at high speed.

Product information:

- ▶ Higher balancing grade and revolution can be done upon request but additional charge is needed.

Standard Accessory: • NUT

Collet	Nut	Coolant Supply Unit	Key	Spanner	Preset Screw
P.X-18~38	P.X-53	P.X-70	P.X-70	P.X-73、75、82	P.X-111



HSK / PRO-E COLLET CHUCK



HSK / PRO-E 筒夾式刀桿

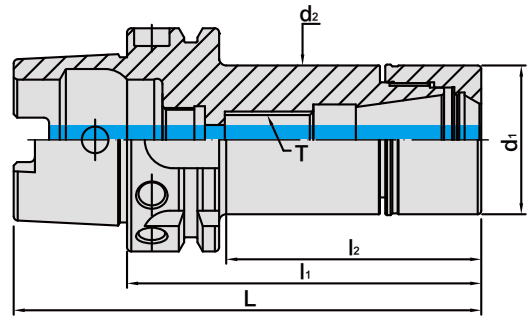

MODEL NO.	TYPE	L	l ₁	l ₂	d ₁	d ₂	T	SIZE RANGE	WEIGHT (KGS)
5073-529-016-070	HSK63A x PRO-E16 - 70	102	70	39	30	30	-	1 ~ 10	0.82
5073-529-016-100	HSK63A x PRO-E16 - 100	132	100	69	30	30	M10 x 1.5P	1 ~ 10	0.97
5073-529-016-125	HSK63A x PRO-E16 - 125	157	125	94	30	30	M10 x 1.5P	1 ~ 10	1.09
5073-529-016-150	HSK63A x PRO-E16 - 150	182	150	119	30	30	M10 x 1.5P	1 ~ 10	1.22
5073-529-016-200	HSK63A x PRO-E16 - 200	232	200	169	30	30	M10 x 1.5P	1 ~ 10	1.47
5073-529-020-070	HSK63A x PRO-E20 - 70	102	70	39	35	35	-	1 ~ 13	0.88
5073-529-020-100	HSK63A x PRO-E20 - 100	132	100	64	35	35	M12 x 1.75P	1 ~ 13	1.08
5073-529-020-125	HSK63A x PRO-E20 - 125	157	125	99	35	35	M12 x 1.75P	1 ~ 13	1.25
5073-529-020-150	HSK63A x PRO-E20 - 150	182	150	114	35	35	M12 x 1.75P	1 ~ 13	1.43
5073-529-020-200	HSK63A x PRO-E20 - 200	232	200	164	35	35	M12 x 1.75P	1 ~ 13	1.78
5073-529-025-070	HSK63A x PRO-E25 - 70	102	70	41	42	42	-	1 ~ 16	0.97
5073-529-025-100	HSK63A x PRO-E25 - 100	132	100	71	42	42	M16 x 2.0P	1 ~ 16	1.26
5073-529-025-125	HSK63A x PRO-E25 - 125	157	125	96	42	42	M16 x 2.0P	1 ~ 16	1.51
5073-529-025-150	HSK63A x PRO-E25 - 150	182	150	121	42	42	M16 x 2.0P	1 ~ 16	1.77
5073-529-025-200	HSK63A x PRO-E25 - 200	232	200	171	42	42	M16 x 2.0P	1 ~ 16	2.28
5073-529-032-080	HSK63A x PRO-E32 - 80	112	80	53	50	50	-	2 ~ 20	1.01
5073-529-032-100	HSK63A x PRO-E32 - 100	132	100	73	50	50	M16 x 2.0P	2 ~ 20	1.39
5073-529-032-125	HSK63A x PRO-E32 - 125	157	125	98	50	50	M16 x 2.0P	2 ~ 20	1.69
5073-529-032-150	HSK63A x PRO-E32 - 150	182	150	123	50	50	M16 x 2.0P	2 ~ 20	2.02
5073-529-032-200	HSK63A x PRO-E32 - 200	232	200	173	50	50	M16 x 2.0P	2 ~ 20	2.70



Features:

- ▶ Superior interchangeability with ER collets.
- ▶ Assembled with ER spring collet (15µm, 10µm, 5µm), ERS metallic sealed collet (10µm, 7µm, 5µm, 3µm) and ERS coolant FOD collet (10µm, 7µm, 5µm, 3µm).
- ▶ The design of enlarged holder ID hole optimizes the coverage of ER collet, shortens the tool overhanging length, and improves runout accuracy and machining stability.
- ▶ The design of straight parts above and below the thread makes PRO-E tool holders have better contact with clamping nuts to achieve higher runout accuracy.
- ▶ PRO-E nuts without slots reduce the wind shear at high speed.

Product information:

- ▶ Balance: G2.5 25,000 rpm. Higher balancing grade and revolution can be done upon request but additional charge is needed.

Standard Accessory: • NUT

Collet	Nut	Coolant Supply Unit	Key	Spanner	Preset Screw
P.X-18~38	P.X-53	P.X-70	P.X-70	P.X-73、75、82	P.X-111



HSK / PRO-E COLLET CHUCK



HSK / PRO-E 筒夾式刀桿

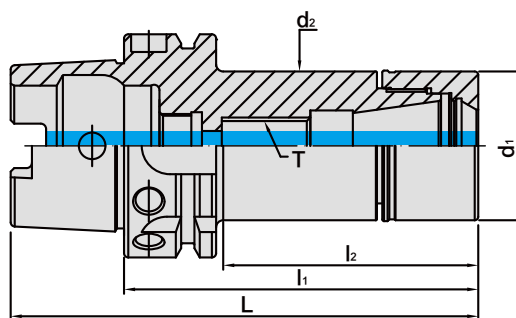

MODEL NO.	TYPE	L	l ₁	l ₂	d ₁	d ₂	T	SIZE RANGE	WEIGHT (KGS)
5074-529-016-070	HSK80A x PRO-E16 - 70	110	70	39	30	30	-	1 ~ 10	1.25
5074-529-016-100	HSK80A x PRO-E16 - 100	140	100	69	30	30	M10 x 1.5P	1 ~ 10	1.40
5074-529-016-125	HSK80A x PRO-E16 - 125	165	125	94	30	30	M10 x 1.5P	1 ~ 10	1.52
5074-529-016-150	HSK80A x PRO-E16 - 150	190	150	119	30	30	M10 x 1.5P	1 ~ 10	1.64
5074-529-016-200	HSK80A x PRO-E16 - 200	240	200	169	30	30	M10 x 1.5P	1 ~ 10	1.88
5074-529-020-070	HSK80A x PRO-E20 - 70	110	70	39	35	35	-	1 ~ 13	1.31
5074-529-020-100	HSK80A x PRO-E20 - 100	140	100	69	35	35	M12 x 1.75P	1 ~ 13	1.52
5074-529-020-125	HSK80A x PRO-E20 - 125	165	125	94	35	35	M12 x 1.75P	1 ~ 13	1.69
5074-529-020-150	HSK80A x PRO-E20 - 150	190	150	119	35	35	M12 x 1.75P	1 ~ 13	1.86
5074-529-020-200	HSK80A x PRO-E20 - 200	240	200	169	35	35	M12 x 1.75P	1 ~ 13	2.20
5074-529-025-070	HSK80A x PRO-E25 - 70	110	70	39	42	42	-	1 ~ 16	1.41
5074-529-025-100	HSK80A x PRO-E25 - 100	140	100	69	42	42	M16 x 2.0P	1 ~ 16	1.69
5074-529-025-125	HSK80A x PRO-E25 - 125	165	125	94	42	42	M16 x 2.0P	1 ~ 16	1.94
5074-529-025-150	HSK80A x PRO-E25 - 150	190	150	119	42	42	M16 x 2.0P	1 ~ 16	2.17
5074-529-025-200	HSK80A x PRO-E25 - 200	240	200	169	42	42	M16 x 2.0P	1 ~ 16	2.69
5074-529-032-080	HSK80A x PRO-E32 - 80	120	80	49	50	50	-	2 ~ 20	1.63
5074-529-032-100	HSK80A x PRO-E32 - 100	140	100	69	50	50	-	2 ~ 20	1.89
5074-529-032-125	HSK80A x PRO-E32 - 125	165	125	94	50	50	M16 x 2.0P	2 ~ 20	2.24
5074-529-032-150	HSK80A x PRO-E32 - 150	190	150	119	50	50	M16 x 2.0P	2 ~ 20	2.60
5074-529-032-200	HSK80A x PRO-E32 - 200	240	200	169	50	50	M16 x 2.0P	2 ~ 20	3.33

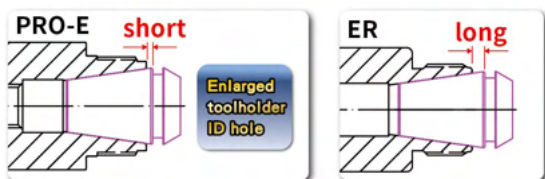

Features:

- ▶ Superior interchangeability with ER collets.
- ▶ Assembled with ER spring collet (15μm, 10μm, 5μm), ERS metallic sealed collet (10μm, 7μm, 5μm, 3μm) and ERS coolant FOD collet (10μm, 7μm, 5μm, 3μm).
- ▶ The design of enlarged holder ID hole optimizes the coverage of ER collet, shortens the tool overhanging length, and improves runout accuracy and machining stability.
- ▶ The design of straight parts above and below the thread makes PRO-E tool holders have better contact with clamping nuts to achieve higher runout accuracy.
- ▶ PRO-E nuts without slots reduce the wind shear at high speed.

Product information:

- ▶ Balance: G2.5 25,000 rpm. Higher balancing grade and revolution can be done upon request but additional charge is needed.

Standard Accessory: • NUT

Collet	Nut	Coolant Supply Unit	Key	Spanner	Preset Screw
P.X-18~38	P.X-53	P.X-70	P.X-70	P.X-73、75、82	P.X-111



HSK / PRO-E COLLET CHUCK



HSK / PRO-E 筒夾式刀桿

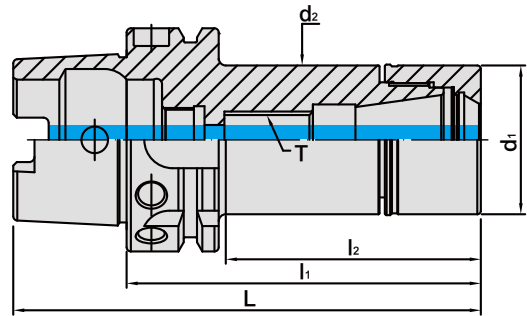

MODEL NO.	TYPE	L	l ₁	l ₂	d ₁	d ₂	T	SIZE RANGE	WEIGHT (KGS)
5075-529-016-100	HSK100A x PRO-E16 - 100	150	100	61	30	30	M10 x 1.5P	1 ~ 10	2.29
5075-529-016-125	HSK100A x PRO-E16 - 125	175	125	86	30	30	M10 x 1.5P	1 ~ 10	2.41
5075-529-016-150	HSK100A x PRO-E16 - 150	200	150	111	30	30	M10 x 1.5P	1 ~ 10	2.52
5075-529-016-200	HSK100A x PRO-E16 - 200	250	200	161	30	30	M10 x 1.5P	1 ~ 10	2.75
5075-529-020-100	HSK100A x PRO-E20 - 100	150	100	61	35	35	M12 x 1.75P	1 ~ 13	2.40
5075-529-020-125	HSK100A x PRO-E20 - 125	175	125	86	35	35	M12 x 1.75P	1 ~ 13	2.57
5075-529-020-150	HSK100A x PRO-E20 - 150	200	150	111	35	35	M12 x 1.75P	1 ~ 13	2.73
5075-529-020-200	HSK100A x PRO-E20 - 200	250	200	161	35	35	M12 x 1.75P	1 ~ 13	3.06
5075-529-025-100	HSK100A x PRO-E25 - 100	150	100	61	42	42	M16 x 2.0P	1 ~ 16	2.58
5075-529-025-125	HSK100A x PRO-E25 - 125	175	125	86	42	42	M16 x 2.0P	1 ~ 16	2.81
5075-529-025-150	HSK100A x PRO-E25 - 150	200	150	111	42	42	M16 x 2.0P	1 ~ 16	3.06
5075-529-025-200	HSK100A x PRO-E25 - 200	250	200	161	42	42	M16 x 2.0P	1 ~ 16	3.55
5075-529-032-100	HSK100A x PRO-E32 - 100	150	100	61	50	50	-	2 ~ 20	2.76
5075-529-032-125	HSK100A x PRO-E32 - 125	175	125	86	50	50	M16 x 2.0P	2 ~ 20	3.09
5075-529-032-150	HSK100A x PRO-E32 - 150	200	150	111	50	50	M16 x 2.0P	2 ~ 20	3.46
5075-529-032-200	HSK100A x PRO-E32 - 200	250	200	161	50	50	M16 x 2.0P	2 ~ 20	4.18
5076-529-016-100	HSK125A x PRO-E16 - 100	163	100	41	30	30	M10 x 1.5P	1 ~ 10	3.91
5076-529-016-125	HSK125A x PRO-E16 - 125	188	125	66	30	30	M10 x 1.5P	1 ~ 10	4.03
5076-529-016-150	HSK125A x PRO-E16 - 150	213	150	91	30	30	M10 x 1.5P	1 ~ 10	4.13
5076-529-016-200	HSK125A x PRO-E16 - 200	263	200	141	30	30	M10 x 1.5P	1 ~ 10	4.34
5076-529-020-100	HSK125A x PRO-E20 - 100	163	100	44	35	35	M12 x 1.75P	1 ~ 13	3.97
5076-529-020-125	HSK125A x PRO-E20 - 125	188	125	69	35	35	M12 x 1.75P	1 ~ 13	4.13
5076-529-020-150	HSK125A x PRO-E20 - 150	213	150	94	35	35	M12 x 1.75P	1 ~ 13	4.29
5076-529-020-200	HSK125A x PRO-E20 - 200	263	200	144	35	35	M12 x 1.75P	1 ~ 13	4.60
5076-529-025-100	HSK125A x PRO-E25 - 100	163	100	47	42	42	M16 x 2.0P	1 ~ 16	4.07
5076-529-025-125	HSK125A x PRO-E25 - 125	188	125	72	42	42	M16 x 2.0P	1 ~ 16	4.31
5076-529-025-150	HSK125A x PRO-E25 - 150	213	150	97	42	42	M16 x 2.0P	1 ~ 16	4.55
5076-529-025-200	HSK125A x PRO-E25 - 200	263	200	147	42	42	M16 x 2.0P	1 ~ 16	5.02
5076-529-032-100	HSK125A x PRO-E32 - 100	163	100	61	50	50	M16 x 2.0P	2 ~ 20	4.02
5076-529-032-125	HSK125A x PRO-E32 - 125	188	125	86	50	50	M16 x 2.0P	2 ~ 20	4.41
5076-529-032-150	HSK125A x PRO-E32 - 150	213	150	111	50	50	M16 x 2.0P	2 ~ 20	4.74
5076-529-032-200	HSK125A x PRO-E32 - 200	263	200	161	50	50	M16 x 2.0P	2 ~ 20	5.43

Standard Accessory: • NUT

Collet	Nut	Coolant Supply Unit	Key	Spanner	Preset Screw
P.X-18~38	P.X-53	P.X-70	P.X-70	P.X-73、75、82	P.X-111



HSK / PRO-E COLLET CHUCK M TYPE



HSK / PRO-E 筒夾式刀桿

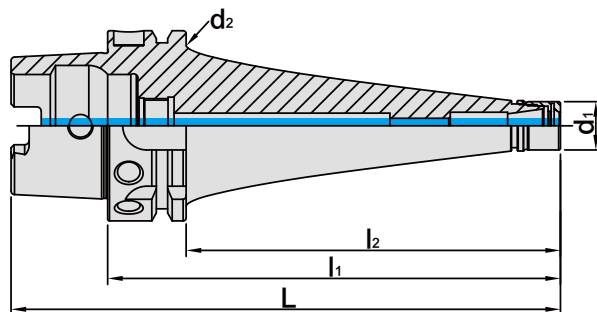

MODEL NO.	TYPE	L	l ₁	l ₂	d ₁	d ₂	T	SIZE RANGE	WEIGHT (KGS)
5073-586-011-150	HSK63A x PRO-E11M - 150CUL	182	150	124	16	53	M6 x 1.0P	2 ~ 7	1.28
5073-586-011-200	HSK63A x PRO-E11M - 200CUL	232	200	174	16	53	M6 x 1.0P	2 ~ 7	1.48



Features:

- ▶ Superior interchangeability with ER collets.
- ▶ Assembled with ER spring collet (15µm, 10µm, 5µm), ERS metallic sealed collet (10µm, 7µm, 5µm, 3µm) and ERS coolant FOD collet (10µm, 7µm, 5µm, 3µm).
- ▶ The design of enlarged holder ID hole optimizes the coverage of ER collet, shortens the tool overhanging length, and improves runout accuracy and machining stability.
- ▶ The design of straight parts above and below the thread makes PRO-E tool holders have better contact with clamping nuts to achieve higher runout accuracy.
- ▶ PRO-E nuts without slots reduce the wind shear at high speed.

Product information: .

- ▶ Higher balancing grade and revolution can be done upon request but additional charge is needed.

Standard Accessory: • NUT

Collet	Nut	Coolant Supply Unit	Key	Spanner	Preset Screw
P.X-18~38	P.X-53	P.X-70	P.X-70	P.X-73、75、82	P.X-111



HSK / UT COLLET CHUCK



HSK / UT 立銑刀夾頭

(ISO 15488)

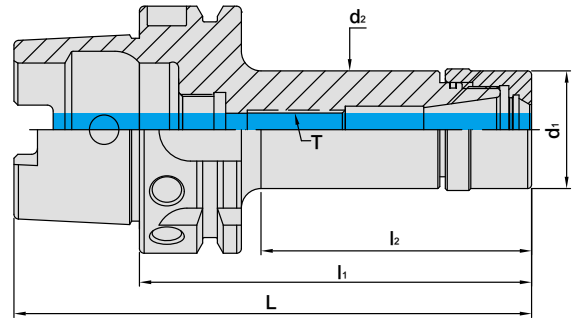
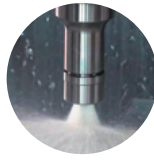

MODEL NO.	TYPE	L	l ₁	l ₂	d ₁	d ₂	T	SIZE RANGE	WEIGHT (KGS)
5070-753-016-060	HSK32A x UT16 - 60	76	60	40	30	26	-	1 ~ 10	0.22
5070-753-020-070	HSK32A x UT20 - 70	86	70	35	35	36	-	1 ~ 13	0.28
5071-753-016-060	HSK40A x UT16 - 60	80	60	38	30	30	-	1 ~ 10	0.31
5071-753-020-065	HSK40A x UT20 - 65	85	65	44	35	34	-	1 ~ 13	0.36
5072-753-020-060	HSK50A x UT20 - 60	85	60	33	35	36	-	1 ~ 13	0.49
5072-753-025-060	HSK50A x UT25 - 60	85	60	34	42	42	-	1 ~ 16	0.51
5072-753-025-070	HSK50A x UT25 - 70	95	70	44	42	42	-	1 ~ 16	0.60
5072-753-025-100	HSK50A x UT25 - 100	125	100	74	42	42	M16 x 2.0P	1 ~ 16	0.85
5072-753-032-075	HSK50A x UT32 - 75	100	75	48	48	42	-	2 ~ 20	0.69
5073-753-016-080	HSK63A x UT16 - 80	112	80	49	30	30	M10 x 1.5P	1 ~ 10	0.86
5073-753-016-100	HSK63A x UT16 - 100	132	100	69	30	30	M10 x 1.5P	1 ~ 10	0.96
5073-753-016-120	HSK63A x UT16 - 120	152	120	89	30	30	M10 x 1.5P	1 ~ 10	1.06
5073-753-016-160	HSK63A x UT16 - 160	192	160	124	30	30	M10 x 1.5P	1 ~ 10	1.28
5073-753-020-080	HSK63A x UT20 - 80	112	80	49	35	36	M12 x 1.75P	1 ~ 13	0.94
5073-753-020-100	HSK63A x UT20 - 100	132	100	69	35	36	M12 x 1.75P	1 ~ 13	1.08
5073-753-020-120	HSK63A x UT20 - 120	152	120	89	35	36	M12 x 1.75P	1 ~ 13	1.23
5073-753-020-160	HSK63A x UT20 - 160	192	160	129	35	36	M12 x 1.75P	1 ~ 13	1.53
5073-753-025-080	HSK63A x UT25 - 80	112	80	49	42	42	M16 x 2.0P	1 ~ 16	1.06
5073-753-025-100	HSK63A x UT25 - 100	132	100	69	42	42	M16 x 2.0P	1 ~ 16	1.24
5073-753-025-120	HSK63A x UT25 - 120	152	120	89	42	42	M16 x 2.0P	1 ~ 16	1.41
5073-753-025-145	HSK63A x UT25 - 145	177	145	114	42	42	M16 x 2.0P	1 ~ 16	1.66
5073-753-025-160	HSK63A x UT25 - 160	192	160	129	42	42	M16 x 2.0P	1 ~ 16	1.81
5073-753-032-080	HSK63A x UT32 - 80	112	80	52	48	48	-	2 ~ 20	1.13
5073-753-032-100	HSK63A x UT32 - 100	132	100	72	48	48	M16 x 2.0P	2 ~ 20	1.33
5073-753-032-120	HSK63A x UT32 - 120	152	120	92	48	48	M16 x 2.0P	2 ~ 20	1.59
5073-753-032-145	HSK63A x UT32 - 145	177	145	117	48	48	M16 x 2.0P	2 ~ 20	1.91
5073-753-032-160	HSK63A x UT32 - 160	192	160	132	48	48	M16 x 2.0P	2 ~ 20	2.11

Features:

- ▶ The deeper holder gauge line optimizes the coverage of ER spring collet and increases machining stability.
- ▶ UT clamping nut is designed without eccentric. Used with ER and ERE spring collets.
- ▶ The O-ring design on the front of holders prevents chips and coolant from entering holders
- ▶ UT nuts without slots reduce the wind shear at high speed.

Product information:

- ▶ Higher balancing grade and revolution can be done upon request but additional charge is needed.
- ▶ Use standard ER collets.

Standard Accessory: • NUT

Collet	Nut	Coolant Supply Unit	Key	Spanner	Preset Screw
P.X-18~21	P.X-53	P.X-70	P.X-70	P.X-73、75、82	P.X-111

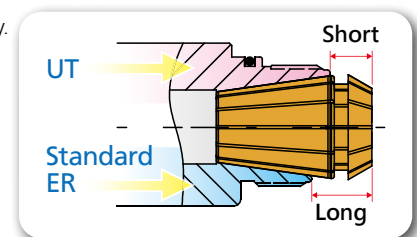

HSK / ER COLLET CHUCK

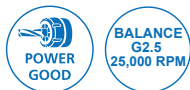

HSK / ER 立銑刀夾頭

(ISO 15488)

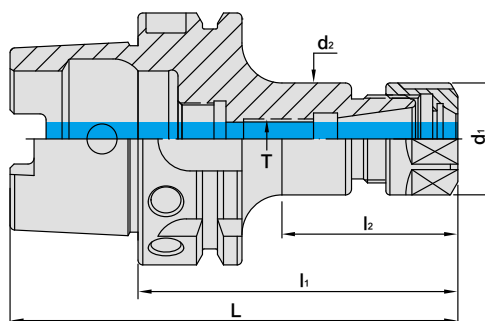

TW PAT NO. M579069
CN PAT NO. ZL201920389611.8

MODEL NO.	TYPE	L	l ₁	l ₂	d ₁	d ₂	T	SIZE RANGE	WEIGHT (KGS)
5071-108-020-080	HSK40A x ER20A - 80	100	80	59	34	32	M10 x 1.5P	1 ~ 13	0.35
5071-110-025-080	HSK40A x ER25 - 80	100	80	59	42	32	M10 x 1.5P	1 ~ 16	0.40
5072-108-016-080	HSK50A x ER16A - 80	105	80	49	28	28	M10 x 1.5P	1 ~ 10	0.50
5072-108-016-100	HSK50A x ER16A - 100	125	100	71	28	28	M10 x 1.5P	1 ~ 10	0.55
5072-108-016-120	HSK50A x ER16A - 120	145	120	91	28	28	M10 x 1.5P	1 ~ 10	0.70
5072-108-020-080	HSK50A x ER20A - 80	105	80	53	34	34	M12 x 1.75P	1 ~ 13	0.60
5072-108-020-100	HSK50A x ER20A - 100	125	100	71	34	34	M12 x 1.75P	1 ~ 13	0.65
5072-108-020-120	HSK50A x ER20A - 120	145	120	91	34	34	M12 x 1.75P	1 ~ 13	0.70
5072-110-025-080	HSK50A x ER25 - 80	105	80	53	42	40	M16 x 2.0P	1 ~ 16	0.70
5072-110-025-100	HSK50A x ER25 - 100	125	100	73	42	42	M16 x 2.0P	1 ~ 16	0.80
5072-110-025-135	HSK50A x ER25 - 135	160	135	108	42	42	M16 x 2.0P	1 ~ 16	0.90
5072-110-032-100	HSK50A x ER32 - 100	125	100	73	50	50	M16 x 2.0P	2 ~ 20	1.35
5072-110-032-135	HSK50A x ER32 - 135	160	135	108	50	50	M16 x 2.0P	2 ~ 20	1.50
5072-110-032-160	HSK50A x ER32 - 160	185	160	133	50	50	M16 x 2.0P	2 ~ 20	1.70
5073-108-016-080	HSK63A x ER16A - 80	112	80	44	28	28	M10 x 1.5P	1 ~ 10	1.00
5073-108-016-100	HSK63A x ER16A - 100	132	100	64	28	28	M10 x 1.5P	1 ~ 10	1.10
5073-108-016-120	HSK63A x ER16A - 120	152	120	84	28	28	M10 x 1.5P	1 ~ 10	1.70
5073-108-016-160	HSK63A x ER16A - 160	192	160	124	28	28	M10 x 1.5P	1 ~ 10	1.90
5073-108-020-080	HSK63A x ER20A - 80	112	80	49	34	34	M12 x 1.75P	1 ~ 13	0.87
5073-108-020-100	HSK63A x ER20A - 100	132	100	66	34	34	M12 x 1.75P	1 ~ 13	1.00
5073-108-020-120	HSK63A x ER20A - 120	152	120	91	34	34	M12 x 1.75P	1 ~ 13	1.11
5073-108-020-125	HSK63A x ER20A - 125	157	125	96	34	34	M12 x 1.75P	1~13	1.15
5073-108-020-150	HSK63A x ER20A - 150	182	150	121	34	34	M12 x 1.75P	1~13	1.31
5073-108-020-160	HSK63A x ER20A - 160	192	160	131	34	34	M12 x 1.75P	1 ~ 13	1.38
5073-108-020-200	HSK63A x ER20A - 200	232	200	171	34	34	M12 x 1.75P	1~13	1.64
5073-108-020-250	HSK63A x ER20A - 250	282	250	221	34	34	M12 x 1.75P	1~13	1.97
5073-108-020-300	HSK63A x ER20A - 300	332	300	271	34	34	M12 x 1.75P	1~13	2.30

Features:

- ▶ According to ISO 15488.
- ▶ This ER collet chuck has superior flexibility for use with all tool types, e.g. drills, taps, mills, reamers.
- ▶ It is recommended to tighten the clamping nuts using a torque wrench. Please refer to the catalogue page of ER POWER GOOD NUT for the info. of recommended tightening torque.

Product information:

- ▶ Higher balancing grade and revolution can be done upon request but additional charge is needed.

Standard Accessory: • NUT

Collet	Nut	Coolant Supply Unit	Key	Spanner	Preset Screw
P.X-18~38	P.X-54~58	P.X-70	P.X-70	P.X-73-76、79、82	P.X-111



HSK / ER COLLET CHUCK



HSK / ER 立銑刀夾頭

(ISO 15488)

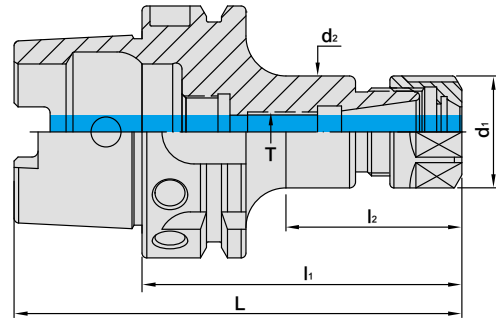

TW PAT NO. M579069
CN PAT NO. ZL201920389611.8

MODEL NO.	TYPE	L	l ₁	l ₂	d ₁	d ₂	T	SIZE RANGE	WEIGHT (KGS)
5073-110-025-080	HSK63A x ER25 - 80	112	80	49	42	42	M16 x 2.0P	1 ~ 16	1.70
5073-110-025-100	HSK63A x ER25 - 100	132	100	69	42	42	M16 x 2.0P	1 ~ 16	1.80
5073-110-025-120	HSK63A x ER25 - 120	152	120	89	42	42	M16 x 2.0P	1 ~ 16	2.00
5073-110-025-150	HSK63A x ER25 - 150	182	150	119	42	42	M16 x 2.0P	1 ~ 16	2.30
5073-110-025-200	HSK63A x ER25 - 200	232	200	169	42	42	M16 x 2.0P	1 ~ 16	2.17
5073-110-025-250	HSK63A x ER25 - 250	282	250	219	42	42	M16 x 2.0P	1 ~ 16	2.68
5073-110-032-080	HSK63A x ER32 - 80	112	80	53	50	50	-	2 ~ 20	1.44
5073-110-032-100	HSK63A x ER32 - 100	132	100	72	50	50	M16 x 2.0P	2 ~ 20	2.55
5073-110-032-145	HSK63A x ER32 - 145	177	145	118	50	50	M16 x 2.0P	2 ~ 20	2.70
5073-110-032-160	HSK63A x ER32 - 160	192	160	133	50	50	M16 x 2.0P	2 ~ 20	3.10
5073-110-032-200	HSK63A x ER32 - 200	232	200	173	50	50	M16 x 2.0P	2 ~ 20	2.78
5073-110-032-250	HSK63A x ER32 - 250	282	250	223	50	50	M16 x 2.0P	2 ~ 20	3.51
5073-110-040-080	HSK63A x ER40 - 80	112	80	53	63	52	-	3 ~ 26	2.65
5073-110-040-100	HSK63A x ER40 - 100	132	100	58	63	60	M20 x 2.0P	3 ~ 26	1.66
5073-110-040-120	HSK63A x ER40 - 120	152	120	78	63	60	M20 x 2.0P	3 ~ 26	2.77
5073-110-040-150	HSK63A x ER40 - 150	182	150	108	63	60	M20 x 2.0P	3 ~ 26	2.95
5073-110-040-170	HSK63A x ER40 - 170	202	170	128	63	60	M20 x 2.0P	3 ~ 26	3.10
5073-110-040-200	HSK63A x ER40 - 200	232	200	173	63	60	M20 x 2.0P	3 ~ 26	3.62
5073-110-040-250	HSK63A x ER40 - 250	282	250	223	63	60	M20 x 2.0P	3 ~ 26	4.69
5073-110-050-120	HSK63A x ER50 - 120	152	120	78	78	60	M24 x 2.0P	6 ~ 34	3.50
5074-110-040-080	HSK80A x ER40 - 80	120	80	51	63	60	-	3 ~ 26	1.76
5074-110-040-100	HSK80A x ER40 - 100	140	100	71	63	60	-	3 ~ 26	2.10
5074-110-040-120	HSK80A x ER40 - 120	160	120	91	63	60	-	3 ~ 26	2.49
5074-110-050-120	HSK80A x ER50 - 120	160	120	91	78	64	-	6 ~ 34	2.99

Features:

- ▶ According to ISO 15488.
- ▶ This ER collet chuck has superior flexibility for use with all tool types, e.g. drills, taps, mills, reamers.
- ▶ It is recommended to tighten the clamping nuts using a torque wrench. Please refer to the catalogue page of ER POWER GOOD NUT for the info. of recommended tightening torque.

Product information:

- ▶ Higher balancing grade and revolution can be done upon request but additional charge is needed.

Standard Accessory: • NUT

Collet	Nut	Coolant Supply Unit	Key	Spanner	Preset Screw
P.X-18~38	P.X-54~58	P.X-70	P.X-70	P.X-73-76、79、82	P.X-111



HSK / ER COLLET CHUCK



HSK / ER 立銑刀夾頭

(ISO 15488)

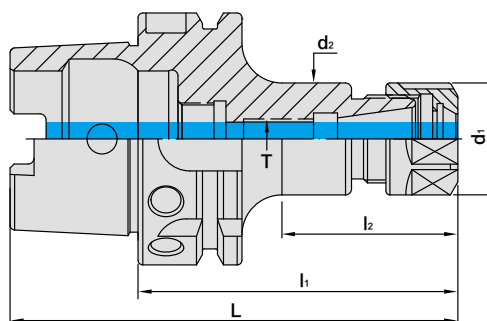

TW PAT NO. M579069
CN PAT NO. ZL201920389611.8

MODEL NO.	TYPE	L	l ₁	l ₂	d ₁	d ₂	T	SIZE RANGE	WEIGHT (KGS)
5075-108-016-080	HSK100A x ER16A - 80	130	80	41	28	28	M10 x 1.5P	1 ~ 10	2.90
5075-108-016-100	HSK100A x ER16A - 100	150	100	61	28	28	M10 x 1.5P	1 ~ 10	2.95
5075-108-016-160	HSK100A x ER16A - 160	210	160	116	28	28	M10 x 1.5P	1 ~ 10	3.45
5075-108-020-080	HSK100A x ER20A - 80	130	80	41	34	34	M12 x 1.75P	1 ~ 13	2.90
5075-108-020-100	HSK100A x ER20A - 100	150	100	61	34	34	M12 x 1.75P	1 ~ 13	3.00
5075-108-020-160	HSK100A x ER20A - 160	210	160	121	34	34	M12 x 1.75P	1 ~ 13	3.30
5075-110-025-100	HSK100A x ER25 - 100	150	100	61	42	42	M16 x 2.0P	1 ~ 16	3.00
5075-110-025-130	HSK100A x ER25 - 130	180	130	96	42	42	M16 x 2.0P	1 ~ 16	3.20
5075-110-025-160	HSK100AxER25-160	210	160	126	42	42	M16x2.0P	1~16	3.07
5075-110-032-100	HSK100A x ER32 - 100	150	100	61	50	50	M16 x 2.0P	2 ~ 20	3.15
5075-110-032-135	HSK100A x ER32 - 135	185	135	96	50	50	M16 x 2.0P	2 ~ 20	3.35
5075-110-032-150	HSK100A x ER32 - 150	200	150	116	50	50	M16 x 2.0P	2 ~ 20	3.50
5075-110-032-160	HSK100AxER32-160	210	160	121	50	50	M16x2.0P	2~20	3.53
5075-110-040-080	HSK100A x ER40 - 80	130	80	46	63	62	-	3 ~ 26	3.30
5075-110-040-120	HSK100A x ER40 - 120	170	120	86	63	63	M20 x 2.0P	3 ~ 26	3.38
5075-110-040-160	HSK100AxER40-160	210	160	126	63	60	M20x2.0P	3~26	4.38
5075-110-040-175	HSK100A x ER40 - 175	225	175	141	63	60	M20 x 2.0P	3 ~ 26	4.20
5075-110-050-100	HSK100A x ER50 - 100	150	100	68	78	78	-	6 ~ 34	4.50
5075-110-050-120	HSK100A x ER50 - 120	170	120	88	78	64	M24 x 2.0P	6 ~ 34	5.00
5076-110-025-100	HSK125A x ER25 - 100	163	100	45	42	42	-	1 ~ 16	4.43
5076-110-025-130	HSK125A x ER25 - 130	193	130	75	42	42	M16 x 2.0P	1 ~ 16	4.71
5076-110-025-160	HSK125A x ER25 - 160	223	160	85	42	42	M16 x 2.0P	1 ~ 16	5.67
5076-110-025-200	HSK125A x ER25 - 200	263	200	125	42	42	M16 x 2.0P	1 ~ 16	6.92
5076-110-032-100	HSK125A x ER32 - 100	163	100	45	50	50	-	2 ~ 20	4.59
5076-110-032-130	HSK125A x ER32 - 130	193	130	75	50	50	M16 x 2.0P	2 ~ 20	5.01
5076-110-032-160	HSK125A x ER32 - 160	223	160	85	50	50	M16 x 2.0P	2 ~ 20	6.02
5076-110-032-200	HSK125A x ER32 - 200	263	200	125	50	50	M16 x 2.0P	2 ~ 20	7.40
5076-110-040-100	HSK125A x ER40 - 100	163	100	45	63	60	-	3 ~ 26	4.80
5076-110-040-130	HSK125A x ER40 - 130	193	130	75	63	60	M20 x 2.0P	3 ~ 26	5.40
5076-110-040-160	HSK125A x ER40 - 160	223	160	85	63	60	M20 x 2.0P	3 ~ 26	6.47
5076-110-040-200	HSK125A x ER40 - 200	263	200	125	63	60	M20 x 2.0P	3 ~ 26	8.01

Features:

- ▶ According to ISO 15488.
- ▶ This ER collet chuck has superior flexibility for use with all tool types, e.g. drills, taps, mills, reamers.
- ▶ It is recommended to tighten the clamping nuts using a torque wrench. Please refer to the catalogue page of ER POWER GOOD NUT for the info. of recommended tightening torque.

Product information:

- ▶ Higher balancing grade and revolution can be done upon request but additional charge is needed.

Standard Accessory: • NUT

Collet	Nut	Coolant Supply Unit	Key	Spanner	Preset Screw
P.X-18~38	P.X-54~58	P.X-70	P.X-70	P.X-73-76、79、82	P.X-111



HSK / SKX COLLET CHUCK



HSK / SKX 立銑刀夾頭



Fig.1

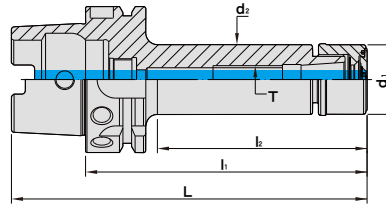
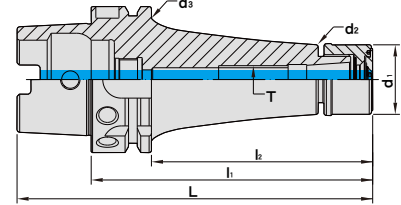

Fig.2



MODEL NO.	TYPE	L	l ₁	l ₂	d ₁	d ₂	d ₃	T	SIZE RANGE	Fig.	WEIGHT (KGS)
5071-790-006-060	HSK40A x SKX6 - 60	80	60	35	19.5	19.5	-	M8 x 1.25P	1 ~ 6	1	0.25
5071-790-010-075	HSK40A x SKX10 - 75	95	75	53	30	30	-	M12 x 1.75P	2 ~ 10	1	0.38
5071-790-016-080	HSK40A x SKX16 - 80	100	80	45	40	40	-	-	2 ~ 16	1	0.44
5072-790-006-060	HSK50A x SKX6 - 60	85	60	29	19.5	19.5	-	-	1 ~ 6	1	0.41
5072-790-006-080	HSK50A x SKX6 - 80	105	80	49	19.5	19.5	-	M8 x 1.25P	1 ~ 6	1	0.44
5072-790-010-060	HSK50A x SKX10 - 60	85	60	29	30	30	-	-	2 ~ 10	1	0.47
5072-790-010-090	HSK50A x SKX10 - 90	115	90	59	30	30	-	M12 x 1.75P	2 ~ 10	1	0.61
5072-790-013-070	HSK50A x SKX13 - 70	95	70	41	33	33	-	-	2 ~ 13	1	0.90
5072-790-013-105	HSK50A x SKX13 - 105	130	105	76	33	33	-	M12 x 1.75P	2 ~ 13	1	1.20
5072-790-016-080	HSK50A x SKX16 - 80	105	80	53	40	40	-	-	2 ~ 16	1	0.63
5072-790-016-105	HSK50A x SKX16 - 105	130	105	78	40	40	-	M18 x 1.5P	2 ~ 16	1	0.83
5073-790-006-060	HSK63A x SKX6 - 60	92	60	29	19.5	19.5	-	-	1 ~ 6	1	0.66
5073-790-006-100	HSK63A x SKX6 - 100	132	100	69	19.5	19.5	-	M8 x 1.25P	1 ~ 6	1	0.70
5073-790-006-120	HSK63A x SKX6 - 120	152	120	94	19.5	19.5	53	M8 x 1.25P	1 ~ 6	2	1.08
5073-790-010-060	HSK63A x SKX10 - 60	92	60	29	30	30	-	-	2 ~ 10	1	0.72
5073-790-010-105	HSK63A x SKX10 - 105	137	105	74	30	30	-	M12 x 1.75P	2 ~ 10	1	0.93
5073-790-010-120	HSK63A x SKX10 - 120	152	120	94	30	30	53	M12 x 1.75P	2 ~ 10	2	1.23
5073-790-013-070	HSK63A x SKX13 - 70	102	70	39	33	33	-	-	2 ~ 13	1	0.90
5073-790-013-105	HSK63A x SKX13 - 105	137	105	74	33	33	-	M12 x 1.75P	2 ~ 13	1	1.20
5073-790-013-120	HSK63A x SKX13 - 120	152	120	89	33	33	-	M12 x 1.75P	2 ~ 13	2	1.50
5073-790-016-080	HSK63A x SKX16 - 80	112	80	49	40	40	-	-	2 ~ 16	1	0.89
5073-790-016-105	HSK63A x SKX16 - 105	137	105	74	40	40	-	M12 x 1.75P	2 ~ 16	1	1.07
5073-790-016-120	HSK63A x SKX16 - 120	152	120	94	40	40	53	M18 x 1.5P	2 ~ 16	2	1.29
5073-790-016-150	HSK63A x SKX16 - 150	182	150	124	40	40	53	M18 x 1.5P	2 ~ 16	2	1.71
5073-790-016-200	HSK63A x SKX16 - 200	232	200	174	40	40	53	M18 x 1.5P	2 ~ 16	2	2.09

Features:

- ▶ Higher clamping force and precision stability than 8° ER design due to 4° taper angle collet design.
- ▶ SKX sealed nuts are capable of coolant pressure up to 70bar.
- ▶ Nuts in smaller OD and without slots are suitable for high-speed machining with less interference.
- ▶ Shorter overhanging tool length, better rigidity.
- ▶ SKX tool holders of the length over 120mm have curved line design for better rigidity.

Product information:

- ▶ SKX sealed cap is optional. Please order SKX sealed cap additionally.
- ▶ With the design of SKX sealed cap, coolant pressure capable up to 70 bar.
- ▶ Used with coolant-through tools.

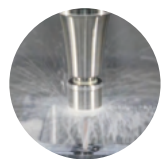

Standard Accessory: • NUT

Collet	Nut	Sealed Cap	Coolant Supply Unit	Key	Spanner	Sealed Cap Spanner	Easy Carry Spanner	Preset Screw
P.X-39~40	P.X-59	P.X-60	P.X-70	P.X-70	P.X-73、75、82	P.X-80	P.X-80	P.X-111



HSK / SKX COLLET CHUCK



HSK / SKX 立銑刀夾頭

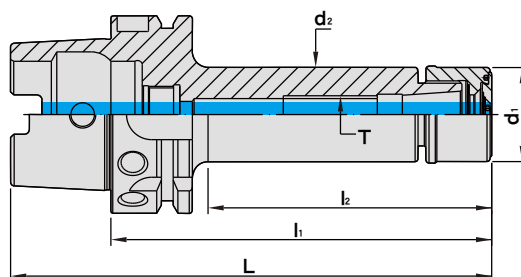

MODEL NO.	TYPE	L	l ₁	l ₂	d ₁	d ₂	d ₃	T	SIZE RANGE	WEIGHT (KGS)
5073-790-020-090	HSK63A x SKX20 - 90	122	90	63	48	48.5	-	-	3 ~ 20	1.14
5073-790-020-105	HSK63A x SKX20 - 105	137	105	78	48	48.5	-	-	3 ~ 20	1.34
5073-790-020-135	HSK63A x SKX20 - 135	167	135	108	48	48.5	-	M22 x 1.5P	3 ~ 20	1.67
5073-790-025-090	HSK63A x SKX25 - 90	122	90	63.5	55	52	-	-	3 ~ 25.4	1.09
5073-790-025-135	HSK63A x SKX25 - 135	167	135	108	55	52	-	M28 x 2.0P	3 ~ 25.4	1.78

Features:

- ▶ Higher clamping force and precision stability than 8° ER design due to 4° taper angle collet design.
- ▶ SKX sealed nuts are capable of coolant pressure up to 70bar.
- ▶ Nuts in smaller OD and without slots are suitable for high-speed machining with less interference.
- ▶ Shorter overhanging tool length, better rigidity.
- ▶ SKX tool holders of the length over 120mm have curved line design for better rigidity.

Product information:

- ▶ SKX sealed cap is optional. Please order SKX sealed cap additionally.
- ▶ With the design of SKX sealed cap, coolant pressure capable up to 70 bar.
- ▶ Used with coolant-through tools.

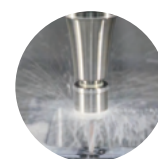

Standard Accessory: • NUT

Collet	Nut	Sealed Cap	Coolant Supply Unit	Key	Spanner	Sealed Cap Spanner	Easy Carry Spanner	Preset Screw
P.X-39~40	P.X-59	P.X-60	P.X-70	P.X-70	P.X-73、75、82	P.X-80	P.X-80	P.X-111



HSK / SKX COLLET CHUCK



HSK / SKX 立銑刀夾頭

(DIN 69893-1)



Fig.1

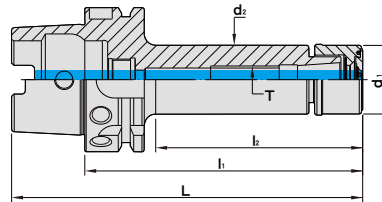
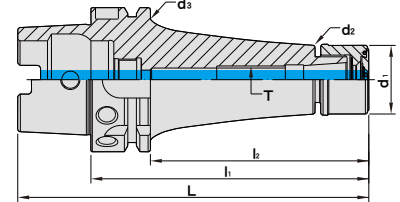

Fig.2



MODEL NO.	TYPE	L	l ₁	l ₂	d ₁	d ₂	d ₃	T	SIZE RANGE	Fig.	WEIGHT (KGS)
5075-790-006-105	HSK100A x SKX6 - 105	155	105	61	19.5	19.5	-	M8 x 1.25P	1 ~ 6	1	2.08
5075-790-010-105	HSK100A x SKX10 - 105	155	105	61	30	30	-	M12 x 1.75P	2 ~ 10	1	2.28
5075-790-010-120	HSK100A x SKX10 - 120	170	120	76	30	30	-	M12 x 1.75P	2 ~ 10	1	2.35
5075-790-010-150	HSK100A x SKX10 - 150	200	150	106	30	30	-	M12 x 1.75P	2 ~ 10	1	2.50
5075-790-013-105	HSK100A x SKX13 - 105	155	105	71	33	33	-	M12 x 1.75P	2 ~ 13	1	2.70
5075-790-013-120	HSK100A x SKX13 - 120	170	120	76	33	33	-	M12 x 1.75P	2 ~ 13	1	3.10
5075-790-013-150	HSK100A x SKX13 - 150	200	150	106	33	33	-	M12 x 1.75P	2 ~ 13	1	3.40
5075-790-016-105	HSK100A x SKX16 - 105	155	105	61	40	40	-	M18 x 1.5P	2 ~ 16	1	2.45
5075-790-016-120	HSK100A x SKX16 - 120	170	120	76	40	40	-	M18 x 1.5P	2 ~ 16	1	2.56
5075-790-016-150	HSK100A x SKX16 - 150	200	150	106	40	40	-	M18 x 1.5P	2 ~ 16	1	2.80
5075-790-020-120	HSK100A x SKX20 - 120	170	120	81	48	48.5	-	M22 x 1.5P	3 ~ 20	1	2.80
5075-790-020-150	HSK100A x SKX20 - 150	200	150	111	48	48.5	-	M22 x 1.5P	3 ~ 20	1	3.15
5075-790-020-200	HSK100A x SKX20 - 200	250	200	171	48	48.5	88	M22 x 1.5P	3 ~ 20	2	4.82
5075-790-025-120	HSK100A x SKX25 - 120	170	120	81	55	55	-	M28 x 2.0P	3 ~ 25.4	1	2.88
5075-790-025-145	HSK100A x SKX25 - 145	195	145	106	55	55	-	M28 x 2.0P	3 ~ 25.4	1	3.21

Features:

- ▶ Higher clamping force and precision stability than 8° ER design due to 4° taper angle collet design.
- ▶ SKX sealed nuts are capable of coolant pressure up to 70bar.
- ▶ Nuts in smaller OD and without slots are suitable for high-speed machining with less interference.
- ▶ Shorter overhanging tool length, better rigidity.
- ▶ SKX tool holders of the length over 120mm have curved line design for better rigidity.

Product information:

- ▶ SKX sealed cap is optional. Please order SKX sealed cap additionally.
- ▶ With the design of SKX sealed cap, coolant pressure capable up to 70 bar.
- ▶ Used with coolant-through tools.

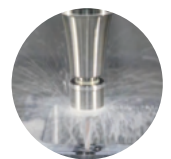

Standard Accessory: • NUT

Collet	Nut	Sealed Cap	Coolant Supply Unit	Key	Spanner	Sealed Cap Spanner	Easy Carry Spanner	Preset Screw
P.X-39~40	P.X-59	P.X-60	P.X-70	P.X-70	P.X-73、75、82	P.X-80	P.X-80	P.X-111



HSK / SK3 COLLET CHUCK



HSK / SK3 高速機專用夾頭

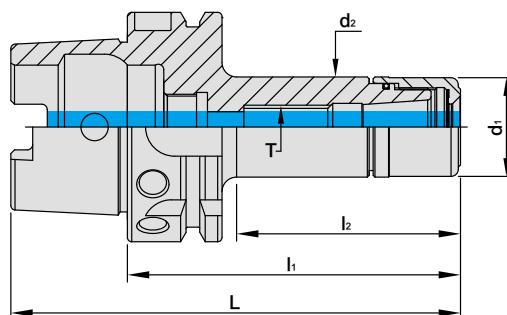

MODEL NO.	TYPE	L	l ₁	l ₂	d ₁	d ₂	T	SIZE RANGE	WEIGHT (KGS)
5070-763-006-045	HSK32A x SK306 - 45	61	45	24	19.5	19.5	-	1 ~ 6	0.50
5070-763-006-060	HSK32A x SK306 - 60	76	60	37	19.5	19.5	M8 x 1.25P	1 ~ 6	0.70
5070-763-010-060	HSK32A x SK310 - 60	76	60	40	27.5	26	-	2 ~ 10	0.70
5072-763-020-090	HSK50A x SK320 - 90	115	90	64	48	48.5	-	3 ~ 20	1.00
5072-763-020-120	HSK50A x SK320 -120	145	120	94	48	48.5	M22 x 1.5P	3 ~ 20	1.30
5073-763-006-090	HSK63A x SK306 - 90	122	90	61	19.5	19.5	M8 x 1.25P	1 ~ 6	1.20
5073-763-010-090	HSK63A x SK310 - 90	122	90	54	27.5	27.5	M12 x 1.75P	2 ~ 10	1.20
5073-763-010-120	HSK63A x SK310 - 120	152	120	84	27.5	27.5	M12 x 1.75P	2 ~ 10	1.40
5073-763-013-070	HSK63A x SK313 - 70	102	70	39	33	33	-	2 ~ 13	1.00
5073-763-013-105	HSK63A x SK313 - 105	137	105	76	33	33	M12 x 1.75P	2 ~ 13	1.10
5073-763-013-120	HSK63A x SK313 - 120	152	120	91	33	33	M12 x 1.75P	2 ~ 13	1.30
5073-763-016-090	HSK63A x SK316 - 90	122	90	61	40	40	-	2 ~ 16	1.20
5073-763-016-120	HSK63A x SK316 - 120	152	120	91	40	40	M18 x 1.5P	2 ~ 16	1.30
5073-763-020-090	HSK63A x SK320 - 90	122	90	62.5	48	48.5	-	3 ~ 20	1.30
5073-763-020-120	HSK63A x SK320 - 120	152	120	92.5	48	48.5	M22 x 1.5P	3 ~ 20	1.60
5073-763-025-090	HSK63A x SK325 - 90	122	90	48	55	55	-	3 ~ 25.4	1.40
5073-763-025-120	HSK63A x SK325 - 120	152	120	78	55	55	M28 x 2.0P	3 ~ 25.4	1.80
5075-763-006-100	HSK100A x SK306 - 100	150	100	61	19.5	19.5	M8 x 1.25P	1 ~ 6	1.50
5075-763-010-100	HSK100A x SK310 - 100	150	100	61	27.5	27.5	M12 x 1.75P	2 ~ 10	1.60
5075-763-013-105	HSK100A x SK313 - 105	155	105	66	33	33	M12 x 1.75P	2 ~ 13	1.70
5075-763-013-120	HSK100A x SK313 - 120	170	120	81	33	33	M12 x 1.75P	2 ~ 13	1.80
5075-763-013-150	HSK100A x SK313 - 150	200	150	111	33	33	M12 x 1.75P	2 ~ 13	1.50
5075-763-016-105	HSK100A x SK316 - 105	155	105	66	40	40	M18 x 1.5P	2 ~ 16	1.70
5052-763-020-105	HSK100A x SK320 - 105	206.75	105	66	48	48.5	-	3 ~ 20	4.00
5052-763-020-135	HSK100A x SK320 - 135	236.75	135	96	48	48.5	M22 x 1.5P	3 ~ 20	3.10
5052-763-025-105	HSK100A x SK325 - 105	206.75	105	66	55	55	-	3 ~ 25.4	3.00
5052-763-025-150	HSK100A x SK325 - 150	251.75	150	111	55	55	M28 x 2.0P	3 ~ 25.4	3.60

Features:

- ▶ Using 4° taper angle collets achieves higher clamping power and stability than 8° design of the ER system.
- ▶ Smaller OD nuts without slots are ideal for high-speed machining with less interference.
- ▶ Dustproof design of adding O rings prevents metal chips and coolants from getting into tool holders.

Product information:

- ▶ Higher balancing grade and revolution can be done upon request but additional charge is needed.

Standard Accessory: • NUT

Collet	Nut	Coolant Supply Unit	key	Spanner	Preset Screw
P.X-39~41	P.X-58	P.X-70	P.X-70	P.X-73、75、82	P.X-111



USC ULTIMATE SIDE CLAMPING CHUCK

BALANCE
G2.5
25,000 RPM

USC 進化型側邊鎖固刀桿

[SBL TYPE]

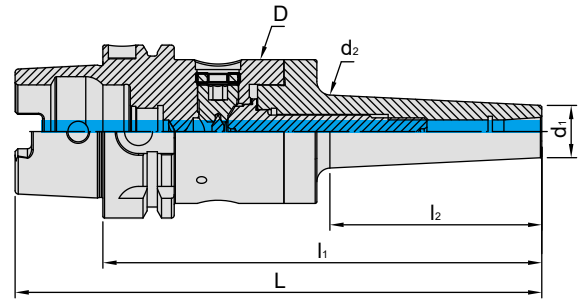

MODEL NO.	TYPE	L	l ₁	l ₂	D	d ₁	d ₂	SIZE RANGE	WEIGHT (KGS)
5073-749-006-160	HSK63A x USC6L - 160	192	160	77.5	52.4	14	30.2	3 ~ 6	1.61
5073-749-012-160	HSK63A x USC12L - 160	192	160	80	52.4	26	32.9	3 ~ 12	2.31

Features:

- ▶ Clamp and unclamp from the side. Quick tool change!
- ▶ The enlarged neck of the tool holder improves machining rigidity.
- ▶ The USC design w/o nut is good for interference reduction.
- ▶ USC is available with center coolant, which effectively removes metal chips, extends tool life and improves surface finish of workpiece.

Collet	Coolant Supply Unit	key	Spanner	FIXED VALUE TORQUE WRENCH
P.X-42~43	P.X-70	P.X-70	P.X-80	P.X-81



USC ULTIMATE SIDE CLAMPING CHUCK

BALANCE
G2.5
25,000 RPM

USC 進化型側邊鎖固刀桿



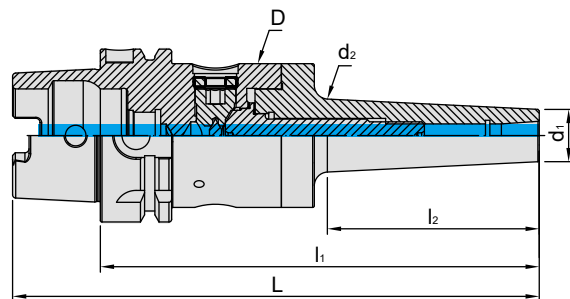

(EBL TYPE)



MODEL NO.	TYPE	L	l ₁	l ₂	D	d ₁	d ₂	SIZE RANGE	WEIGHT (KGS)
5073-747-006-150	HSK63A x USC6B - 150	182	150	67.2	52.4	19.05	25.6	3 ~ 6	1.73
5073-747-006-200	HSK63A x USC6B - 200	232	200	117.2	52.4	19.05	30.5	3 ~ 6	1.96

Features:

- ▶ Clamp and unclamp from the side. Quick tool change!
- ▶ The enlarged neck of the tool holder improves machining rigidity.
- ▶ The USC design w/o nut is good for interference reduction.
- ▶ USC is available with center coolant, which effectively removes metal chips, extends tool life and improves surface finish of workpiece.

Collet	Coolant Supply Unit	key	Spanner	FIXED VALUE TORQUE WRENCH
 P.X-44	 P.X-70	 P.X-70	 P.X-80	 P.X-81



USC ULTIMATE SIDE CLAMPING CHUCK

BALANCE
G2.5
25,000 RPM

USC 進化型側邊鎖固刀桿

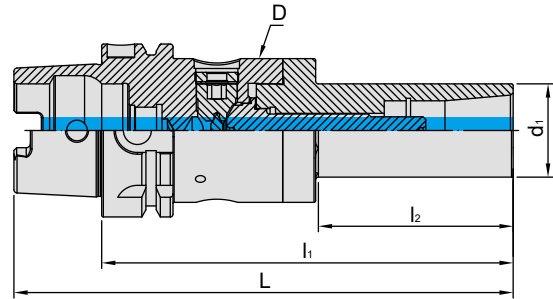

[SFS TYPE]



MODEL NO.	TYPE	L	l ₁	l ₂	D	d ₁	WEIGHT (KGS)
5073-750-012-150	HSK63A x USC12S - 150	182	150	97	52.4	34	1.61

Features:

- ▶ Clamp and unclamp from the side. Quick tool change!
- ▶ The enlarged neck of the tool holder improves machining rigidity.
- ▶ The USC design w/o nut is good for interference reduction.
- ▶ USC is available with center coolant, which effectively removes metal chips, extends tool life and improves surface finish of workpiece.

SFS Extension	MFS Extension	Coolant Supply Unit	key	Spanner	FIXED VALUE TORQUE WRENCH
 P.Q-120	 P.Q-121~122	 P.X-70	 P.X-70	 P.X-80	 P.X-81



HSK / SBL SLIM-FIT COLLET CHUCK

5 μ m

BALANCE
G2.5
25,000 RPM

HSK / SBL 後拉式立銑刀夾頭

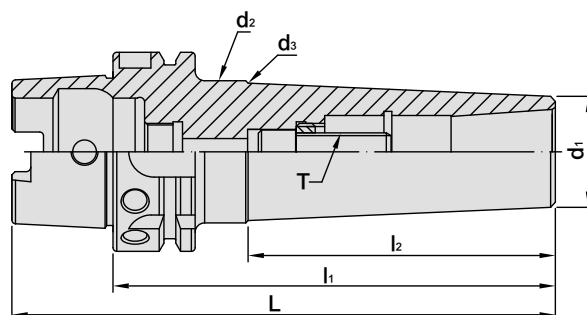





MODEL NO.	TYPE	L	l ₁	l ₂	d ₁	d ₂	d ₃	T	RECOMMENDED TORQUE		SIZE RANGE	WEIGHT (KGS)
									N.m	1bf-ft		
5072-648-006-080	HSK50A x SBL6 - 80	105	80	44	14	18	-	M6 x 1.0P	12	9	3 ~ 6	1.40
5072-648-006-120	HSK50A x SBL6 - 120	145	120	84	14	22	-	M6 x 1.0P	12	9	3 ~ 6	1.50
5072-648-012-110	HSK50A x SBL12 - 110	135	110	65	26	42	36	M10 x 1.5P	45	33	3 ~ 12	1.50
5072-648-012-130	HSK50A x SBL12 - 130	155	130	86	26	42	39	M10 x 1.5P	45	33	3 ~ 12	1.85
5072-648-020-120	HSK50A x SBL20 - 120	145	120	93	35	42	-	M12 x 1.75P	60	44	3 ~ 20	1.80
5072-648-020-150	HSK50A x SBL20 - 150	175	150	123	35	42	-	M12 x 1.75P	60	44	3 ~ 20	2.00
5073-648-006-080	HSK63A x SBL6 - 80	112	80	39	14	18	-	M6 x 1.0P	12	9	3 ~ 6	1.70
5073-648-006-120	HSK63A x SBL6 - 120	152	120	79	14	22	-	M6 x 1.0P	12	9	3 ~ 6	1.90
5073-648-008-130	HSK63A x SBL8 - 130	162	130	94	20	29	-	M8 x 1.25P	29	21	3 ~ 8	1.99
5073-648-008-150	HSK63A x SBL8 - 150	182	150	114	20	32.0	-	M8 x 1.25P	29	21	3 ~ 8	1.11
5073-648-012-110	HSK63A x SBL12 - 110	142	110	79	26	37	-	M10 x 1.5P	45	33	3 ~ 12	1.80
5073-648-012-150	HSK63A x SBL12 - 150	182	150	119	26	42	-	M10 x 1.5P	45	33	3 ~ 12	2.00
5073-648-020-120	HSK63A x SBL20 - 120	152	120	89	35	42	-	M12 x 1.75P	60	44	3 ~ 20	2.00
5073-648-020-140	HSK63A x SBL20 - 140	172	140	97	35	45	43	M12 x 1.75P	60	44	3 ~ 20	2.45
5075-648-006-120	HSK100A x SBL6 - 120	170	120	76	14	22	-	M6 x 1.0P	12	9	3 ~ 6	2.15
5075-648-008-130	HSK100A x SBL8 - 130	180	130	86	20	29	-	M8 x 1.25P	29	21	3 ~ 8	2.31
5075-648-008-150	HSK100A x SBL8 - 150	200	150	106	20	31	-	M8 x 1.25P	29	21	3 ~ 8	2.43
5075-648-012-120	HSK100A x SBL12 - 120	170	120	81	26	37	-	M10 x 1.5P	45	33	3 ~ 12	2.40
5075-648-020-135	HSK100A x SBL20 - 135	185	135	88	35	45	42	M12 x 1.75P	60	44	3 ~ 20	2.74
5075-648-025-150	HSK100A x SBL25 - 150	200	150	111	40	49	-	M16 x 1.5P	90	66	6 ~ 25.4	2.80

Features:

- ▶ The design of non-clamping nut and slim front ends reduces interference, ideal for deep hole machining.
- ▶ Taper angle 4° increases the stability of clamping precision.
- ▶ T.I.R. is within 5 μ m at 4D distance.

Product information:

- ▶ Higher balancing grade and revolution can be done upon request but additional charge is needed.

Collet	Coolant Supply Unit	Key	Spanner	Screw
				
P.X-42	P.X-70	P.X-70	P.X-80	P.X-114



HSK / SBLC SLIM-FIT COLLET CHUCK

5 μ m

BALANCE
G2.5
25,000 RPM

HSK / SBLC 後拉式立銑刀夾頭

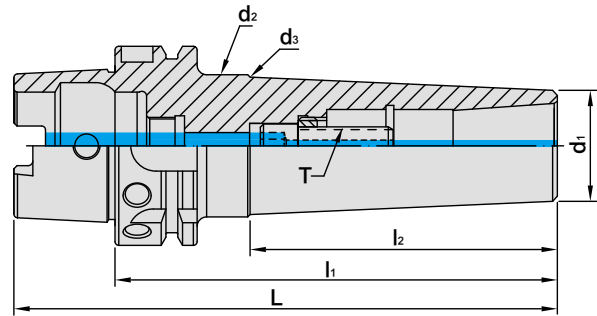
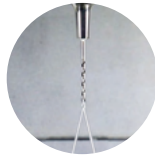

MODEL NO.	TYPE	L	l ₁	l ₂	d ₁	d ₂	d ₃	T	RECOMMENDED TORQUE		SIZE RANGE	WEIGHT (KGS)
									N.m	1bf-ft		
5072-623-006-080	HSK50A x SBLC6 - 80	105	80	44	14	18	-	M6 x 1.0P	12	9	3 ~ 6	1.40
5072-623-006-120	HSK50A x SBLC6 - 120	145	120	84	14	22	-	M6 x 1.0P	12	9	3 ~ 6	1.50
5072-623-012-110	HSK50A x SBLC12 - 110	135	110	65	26	42	36	M10 x 1.5P	45	33	3 ~ 12	1.50
5072-623-012-130	HSK50A x SBLC12 - 130	155	130	86	26	42	39	M10 x 1.5P	45	33	3 ~ 12	1.85
5072-623-020-120	HSK50A x SBLC20 - 120	145	120	93	35	42	-	M12 x 1.75P	60	44	3 ~ 20	1.80
5072-623-020-150	HSK50A x SBLC20 - 150	175	150	123	35	42	-	M12 x 1.75P	60	44	3 ~ 20	2.00
5073-623-006-080	HSK63A x SBLC6 - 80	112	80	39	14	18	-	M6 x 1.0P	12	9	3 ~ 6	1.70
5073-623-006-120	HSK63A x SBLC6 - 120	152	120	79	14	22	-	M6 x 1.0P	12	9	3 ~ 6	1.90
5073-623-008-130	HSK63A x SBLC8 - 130	162	130	94	20	29	-	M8 x 1.25P	29	21	3 ~ 8	0.99
5073-623-008-150	HSK63A x SBLC8 - 150	182	150	114	20	32.0	-	M8 x 1.25P	29	21	3 ~ 8	1.11
5073-623-012-110	HSK63A x SBLC12 - 110	142	110	79	26	37	-	M10 x 1.5P	45	33	3 ~ 12	1.80
5073-623-012-150	HSK63A x SBLC12 - 150	182	150	119	26	42	-	M10 x 1.5P	45	33	3 ~ 12	2.00
5073-623-020-120	HSK63A x SBLC20 - 120	152	120	89	35	42	-	M12 x 1.75P	60	44	3 ~ 20	2.00
5073-623-020-140	HSK63A x SBLC20 - 140	172	140	97	35	45	43	M12 x 1.75P	60	44	3 ~ 20	2.45
5075-623-006-120	HSK100A x SBLC6 - 120	170	120	76	14	22	-	M6 x 1.0P	12	9	3 ~ 6	2.15
5075-623-008-130	HSK100A x SBLC8 - 130	180	130	86	20	29	-	M8 x 1.25P	29	21	3 ~ 8	2.31
5075-623-008-150	HSK100A x SBLC8 - 150	200	150	106	20	31	-	M8 x 1.25P	29	21	3 ~ 8	2.43
5075-623-012-120	HSK100A x SBLC12 - 120	170	120	81	26	37	-	M10 x 1.5P	45	33	3 ~ 12	2.40
5075-623-020-135	HSK100A x SBLC20 - 135	185	135	88	35	45	42	M12 x 1.75P	60	44	3 ~ 20	2.74
5075-623-025-150	HSK100A x SBLC25 - 150	200	150	111	40	49	-	M16 x 1.5P	90	66	6 ~ 25.4	2.80

Features:

- ▶ SBLC collet chuck used for center coolant improves the metal chip removal capability and the surface finish of the workpiece.
- ▶ The design of non-clamping nut and slim front ends reduces interference, ideal for deep hole machining.
- ▶ T.I.R. is within 5 μ m at 4D distance.
- ▶ Taper angle 4° increases the stability of clamping precision.

Product information:

- ▶ Higher balancing grade and revolution can be done upon request but additional charge is needed.
- ▶ Used with SLC sealed collet and coolant through cutters.

Standard Accessory: • SPANNER

Collet	Coolant Supply Unit	Key	Spanner	Screw
P.X-43	P.X-70	P.X-70	P.X-80	P.X-114

HSK / EBL SLIM-FIT COLLET CHUCK

5 μ m

BALANCE
G2.5
25,000 RPM

HSK / EBL 後拉式刀桿

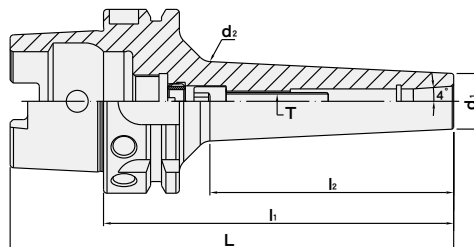

MODEL NO.	TYPE	L	l ₁	l ₂	d ₁	d ₂	T	RECOMMENDED TORQUE		SIZE RANGE	WEIGHT (KGS)
								N.m	lbf-ft		
5072-277-006-125	HSK50A x EBL6 - 125	150	125	94.2	19.05	28.2	M6 x 1.0P	12	9	3 ~ 6	0.79
5072-277-006-150	HSK50A x EBL6 - 150	175	150	119.2	19.05	30.7	M6 x 1.0P	12	9	3 ~ 6	0.91
5073-277-006-125	HSK63A x EBL6 - 125	157	125	88.8	19.05	27.7	M6 x 1.0P	12	9	3 ~ 6	1.06
5073-277-006-150	HSK63A x EBL6 - 150	182	150	115	19.05	30.3	M6 x 1.0P	12	9	3 ~ 6	1.19
5073-277-008-125	HSK63A x EBL8 - 125	157	125	90.4	22.225	31	M8 x 1.25P	29	21	3 ~ 8	1.12
5073-277-008-150	HSK63A x EBL8 - 150	182	150	116.7	22.225	33.6	M8 x 1.25P	29	21	3 ~ 8	1.26
5075-277-006-125	HSK100A x EBL6 - 125	175	125	85.6	19.05	27.4	M6 x 1.0P	12	9	3 ~ 6	2.34
5075-277-006-150	HSK100A x EBL6 - 150	200	150	111.9	19.05	30	M6 x 1.0P	12	9	3 ~ 6	2.49
5075-277-008-125	HSK100A x EBL8 - 125	175	125	87.3	22.225	30.7	M8 x 1.25P	29	21	3 ~ 8	2.41
5075-277-008-150	HSK100A x EBL8 - 150	200	150	113.6	22.225	33.3	M8 x 1.25P	29	21	3 ~ 8	2.55



▶ SBL







▶ EBL

Features:

- ▶ EBL collet with extended length shortens tool overhanging length and improves the machining stability.
- ▶ The optimized design of thicker neck improves the machining rigidity and eliminates vibration, resulting in excellent surface finish of workpiece.

Standard Accessory: • SPANNER

Collet	Coolant Supply Unit	Key	Spanner	Screw
				
P.X-44	P.X-70	P.X-70	P.X-80	P.X-114



HSK / EBLC SLIM-FIT COLLET CHUCK

5 μ m

BALANCE
G2.5
25,000 RPM



HSK / EBLC 後拉式刀桿

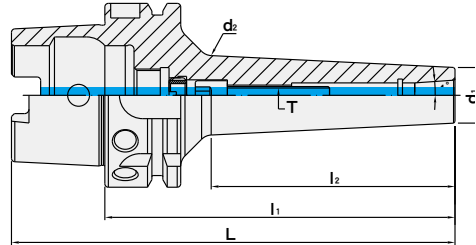

MODEL NO.	TYPE	L	l ₁	l ₂	d ₁	d ₂	T	RECOMMENDED TORQUE		SIZE RANGE	WEIGHT (KGS)
								N.m	lbf-ft		
5072-195-006-125	HSK50A x EBLC6 - 125	150	125	94.2	19.05	28.2	M6x1.0P	12	9	3~6	0.79
5072-195-006-150	HSK50A x EBLC6 - 150	175	150	119.2	19.05	30.7	M6x1.0P	12	9	3~6	0.91
5073-195-006-125	HSK63A x EBLC6 - 125	157	125	88.8	19.05	27.7	M6x1.0P	12	9	3~6	1.06
5073-195-006-150	HSK63A x EBLC6 - 150	182	150	115	19.05	30.3	M6x1.0P	12	9	3~6	1.19
5073-195-008-125	HSK63A x EBLC8 - 125	157	125	90.4	22.225	31	M8x1.25P	29	21	3~8	1.12
5073-195-008-150	HSK63A x EBLC8 - 150	182	150	116.7	22.225	33.6	M8x1.25P	29	21	3~8	1.26
5075-195-006-125	HSK100A x EBLC6 - 125	175	125	85.6	19.05	27.4	M6x1.0P	12	9	3~6	2.34
5075-195-006-150	HSK100A x EBLC6 - 150	200	150	111.9	19.05	30	M6x1.0P	12	9	3~6	2.49
5075-195-008-125	HSK100A x EBLC8 - 125	175	125	87.3	22.225	30.7	M8x1.25P	29	21	3~8	2.41
5072-195-008-150	HSK100A x EBLC8 - 150	200	150	113.6	22.225	33.3	M8x1.25P	29	21	3~8	2.55



▶ SBLC



▶ EBLC

Features:

- ▶ EBLC collet chuck used for center coolant improves the metal chip removal capability and the surface finish of the workpiece.
- ▶ EBL collet with extended length shortens tool overhanging length and improves the machining stability.
- ▶ The optimized design of thicker neck improves the machining rigidity and eliminates vibration, resulting in excellent surface finish of workpiece.
- ▶ EBL sealed collet is capable of coolant pressure up to 25bar.

Standard Accessory: • SPANNER

Collet	Coolant Supply Unit	Key	Spanner	Screw
P.X-44	P.X-70	P.X-70	P.X-80	P.X-114



HSK / HBL SLIM-FIT COLLET CHUCK



HSK / HBL 後拉式立銑刀夾頭

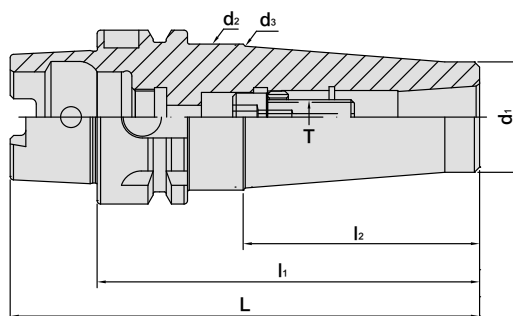

MODEL NO.	TYPE	L	l ₁	l ₂	d ₁	d ₂	d ₃	T	WEIGHT (KGS)
5072-275-012-110	HSK50A x HBL12 - 110	135	110	68	31.75	42	40.79	M10 x 1.5P	1.70
5072-275-012-130	HSK50A x HBL12 - 130	155	130	75.12	31.75	42	-	M10 x 1.5P	2.05
5072-275-020-120	HSK50A x HBL20 - 120	145	120	54.66	38.1	42	-	M12 x 1.75P	2.00
5072-275-020-150	HSK50A x HBL20 - 150	175	150	54.66	38.1	42	-	M12 x 1.75P	2.20
5073-275-012-110	HSK63A x HBL12 - 110	142	110	79.22	31.75	37.79	-	M10 x 1.5P	2.00
5073-275-012-150	HSK63A x HBL12 - 150	182	150	121.13	31.75	41.45	-	M10 x 1.5P	2.20
5073-275-020-120	HSK63A x HBL20 - 120	152	120	89.22	38.1	45.02	-	M12 x 1.75P	2.20
5073-275-020-140	HSK63A x HBL20 - 140	172	140	89.02	38.1	45	-	M12 x 1.75P	2.65
5075-275-012-120	HSK100A x HBL12 - 120	170	120	79.05	31.75	37.78	-	M10 x 1.5P	2.60
5075-275-020-135	HSK100A x HBL20 - 135	185	135	89.02	38.1	45	-	M12 x 1.75P	2.94
5075-275-025-150	HSK100A x HBL25 - 150	200	150	111.44	44.45	53.31	-	M16 x 1.5P	3.00

HLB Cutter for HBL Slim-Fit Collet Chuck

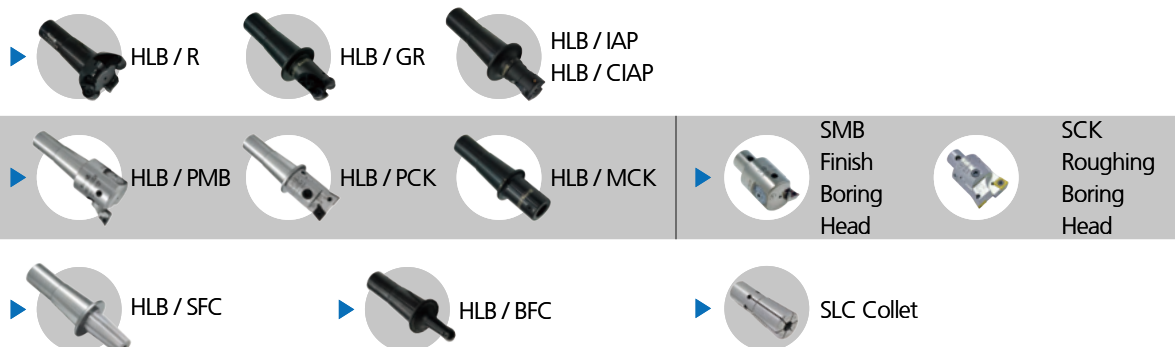

Features:

- ▶ Two-face contact between collet taper, collet flange and the end of HBL tool holder, increases the rigidity of machining.
- ▶ Modular system, assembled with HLB tools.
- ▶ HBL drawbar clamping design strengthens the axial clamping force.

Product information:

- ▶ When assembling with coolant through HLB cutter SLC saeled collet, please change the screw into coolant screw, which is available to order separately.
- ▶ Higher balancing grade and revolution can be done upon request but additional charge is needed.

SLC Collet	Coolant Supply Unit	Key	Spanner	HLB CUTTER	Screw
P.X-42~43	P.X-70	P.X-70	P.X-80	P.X-83~97	P.X-114



HSK / SMG NON-PULLOUT MILLING CHUCK

5 μ m
BALANCE
G2.5
25,000 RPM

HSK / SMG 防脫刀刀桿

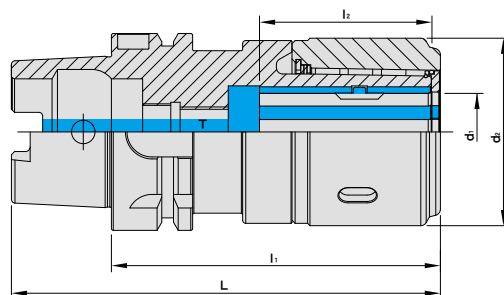







TW PAT NO. M610919

MODEL NO.	TYPE	L	l ₁	l ₂	d ₁	d ₂	T	WEIGHT (KGS)
5073 - 626 - 025 - 105	HSK63A x SMG25 - 105	137	105	55	25	60	M16 x 1.5P	1.85
5073 - 626 - 032 - 120	HSK63A x SMG32 - 120	152	120	61.8	32	71	M16 x 1.5P	1.80
5075 - 626 - 025 - 115	HSK100A x SMG25 - 115	165	115	55	25	60	M16 x 1.5P	3.30
5075 - 626 - 032 - 120	HSK100A x SMG32 - 120	170	120	61.8	32	71	M16 x 1.5P	3.40

Features:

- ▶ Used with Weldon shank cutters.(ISO3338-2, JIS B4005, DIN1835)
- ▶ Ideal for machining difficult-to-cut materials like titanium alloys and nickel alloys in heavy duty applications.
- ▶ Patented backlash remove screw and positioning chip effectively lock cutters, preventing tool slippage and pullout during process.
- ▶ The design of 3 coolant grooves on the front can deliver coolant to remove metal chips and extend cutter use life.

Standard Accessory: • Backlash remove screw • Positioning chip • Spanners

Coolant Supply Unit	Key	Spanner	Allen Wrench	Positioning Chip	Backlash Remove Screw
					
P.X-70	P.X-70	P.X-80	P.X-80	P.X-115	P.X-115

HSK / MLD MULTI - LOCK MILLING CHUCK

HSK / MLD 直式筒夾銑床夾頭



TW PAT NO. M447277
 TW PAT NO. M430337
 TW PAT NO. M451185
 CN PAT NO. ZL201220749784.4
 CH PAT NO. ZL201220749942.6

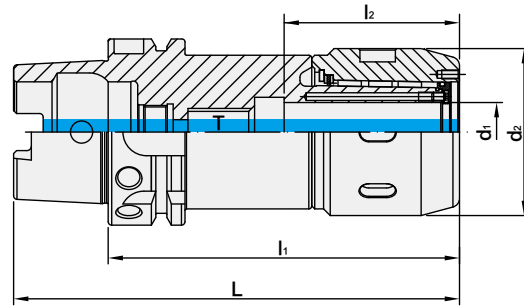

MODEL NO.	TYPE	L	l ₁	l ₂	d ₁	d ₂	T	WEIGHT (KGS)
5072-460-012-100	HSK50A x MLD12 - 100	125	100	46.7	12	42	-	1.52
5072-460-016-100	HSK50A x MLD16 - 100	125	100	56.7	16	48	-	1.59
5072-460-020-120	HSK50A x MLD20 - 120	145	120	59.3	20	56.5	M12 x 1.75P	1.62
5073-460-012-090	HSK63A x MLD12 - 90	122	90	46.7	12	42	-	1.62
5073-460-016-100	HSK63A x MLD16 - 100	132	100	56.7	16	48	-	1.62
5073-460-020-120	HSK63A x MLD20 - 120	152	120	59.3	20	56.5	M16 x 2.0P	1.68
5073-460-025-105	HSK63A x MLD25 - 105	137	105	58.2	25	60	-	1.82
5073-460-032-120	HSK63A x MLD32 - 120	152	120	71.7	32	71	-	1.76
5075-460-012-115	HSK100A x MLD12 - 115	165	115	46.7	12	42	M12 x 1.75P	3.10
5075-460-016-120	HSK100A x MLD16 - 120	170	120	56.7	16	48	M12 x 1.75P	3.10
5075-460-020-120	HSK100A x MLD20 - 120	170	120	59.3	20	56.5	M16 x 2.0P	3.40
5075-460-025-115	HSK100A x MLD25 - 115	165	115	58.2	25	60	-	3.30
5075-460-032-120	HSK100A x MLD32 - 120	170	120	71.7	32	71	-	3.40
5076-460-020-135	HSK125A x MLD20 - 135	198	135	59.3	20	56.5	-	6.70
5076-460-020-165	HSK125A x MLD20 - 165	228	165	59.3	20	56.5	M12 x 1.75P	7.60
5076-460-025-135	HSK125A x MLD25 - 135	198	135	58.2	25	60	M16 x 2.0P	7.10
5076-460-032-135	HSK125A x MLD32 - 135	198	135	71.7	32	71	-	7.80
5076-460-032-165	HSK125A x MLD32 - 165	228	165	71.7	32	71	M16 x 2.0P	9.10
5076-460-042-135	HSK125A x MLD42 - 135	198	135	84.8	42	90	-	8.00

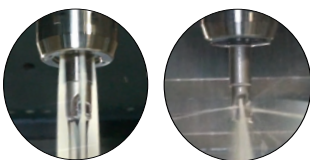

Features:

- ▶ The special slotted design of the internal hole increases the clamping force and decreases vibration, making this milling chuck set suitable for heavy-duty machining.
- ▶ Collet runout accuracy: HSC collet 5μm and SSC collet 20μm two options to choose from.
- ▶ After fastening, the nuts and tool holders contact tight to enhance the cutting rigidity and achieve dustproof purposes.
- ▶ Coolant options: through the center of the holder or cutter. Use a sealed cap and SR ring for coolant through the cutter.

Product information:

- ▶ The pre-balance reaches G6.3 8,000 rpm. Higher balancing grade and revolution can be done upon request but additional charge is needed.

Standard Accessory: • NUT

Collet	Sealed Cap	SR Sealed Ring	Coolant Supply Unit	Key	Spanner	Spanner	Set Screw
P.X-46~47	P.X-62	P.X-63	P.X-70	P.X-70	P.X-79~80	P.X-82	P.X-111



HSK / MLD MULTI - LOCK MILLING CHUCK

HSK / MLD 直式筒夾銑床夾頭

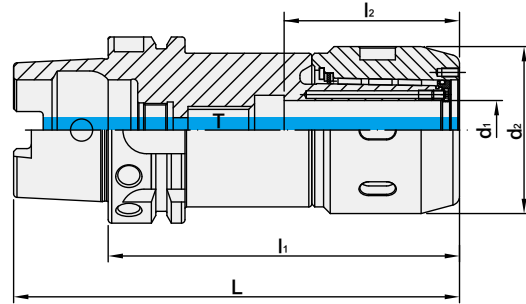

TW PAT NO. M447277
 TW PAT NO. M430337
 TW PAT NO. M451185
 CN PAT NO. ZL201220749784.4
 CH PAT NO. ZL201220749942.6

INCHES

MODEL NO.	TYPE	L	l ₁	l ₂	d ₁	d ₂	T	WEIGHT (KGS)
5072-460-A32-400	HSK50A x MLD1/2" - 4"	4.984	4	1.84	0.5	1.654	-	1.52
5072-460-A40-394	HSK50A x MLD5/8" - 3.94"	4.921	3.94	2.23	0.625	1.889	-	1.62
5072-460-A48-400	HSK50A x MLD3/4" - 4"	4.984	4	2.34	0.75	2.224	-	1.62
5073-460-A32-354	HSK63A x MLD1/2" - 3.54"	4.803	3.54	1.84	0.5	1.654	-	1.72
5073-460-A40-394	HSK63A x MLD5/8" - 3.94"	5.197	3.94	2.23	0.625	1.889	-	1.75
5073-460-A48-400	HSK63A x MLD3/4" - 4"	5.26	4	2.34	0.75	2.224	-	1.80
5073-460-A64-413	HSK63A x MLD1" - 4.13"	5.394	4.13	2.49	1	2.362	-	1.65
5073-460-A72-472	HSK63A x MLD1-1/4" - 4.72"	5.984	4.72	2.8	1.25	2.795	-	1.68
5075-460-A32-453	HSK100A x MLD1/2" - 4.53"	6.496	4.53	1.84	0.5	1.654	M12 x 1.75P	1.65
5075-460-A40-453	HSK100A x MLD5/8" - 4.53"	6.496	4.53	2.23	0.625	1.889	M12 x 1.75P	1.65
5075-460-A48-472	HSK100A x MLD3/4" - 4.72"	6.693	4.72	2.34	0.75	2.224	-	1.70
5075-460-A64-453	HSK100A x MLD1" - 4.53"	6.496	4.53	2.49	1	2.362	-	1.72
5075-460-A72-472	HSK100A x MLD1-1/4" - 4.72"	6.693	4.72	2.8	1.25	2.795	-	1.76

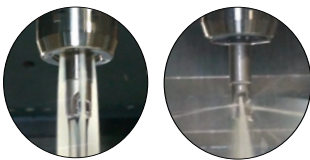

Features:

- ▶ The special slotted design of the internal hole increases the clamping force and decreases vibration, making this milling chuck set suitable for heavy-duty machining.
- ▶ Collet runout accuracy: HSC collet 5μm and SSC collet 20μm two options to choose from.
- ▶ After fastening, the nuts and tool holders contact tight to enhance the cutting rigidity and achieve dustproof purposes.
- ▶ Coolant options: through the center of the holder or cutter. Use a sealed cap and SR ring for coolant through the cutter.

Product information:

- ▶ The pre-balance reaches G6.3 8,000 rpm. Higher balancing grade and revolution can be done upon request but additional charge is needed.

Standard Accessory: • NUT

Collet	Sealed Cap	SR Sealed Ring	Coolant Supply Unit	Key	Spanner	Spanner	Set Screw
P.X-46~47	P.X-62	P.X-63	P.X-70	P.X-70	P.X-79~80	P.X-82	P.X-111



HSK / EOC COLLET CHUCK



HSK / EOC 立銑刀夾頭

(ISO 10897)

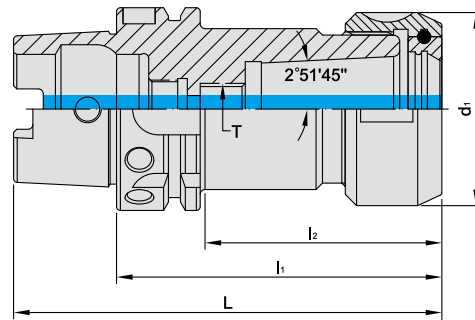

MODEL NO.	TYPE	L	l ₁	l ₂	d ₁	T	SIZE RANGE	WEIGHT (KGS)
5072-121-016-100	HSK50A x EOC16 - 100	125	100	74	43	M12 x 1.75P	2 ~ 16	0.70
5072-121-016-120	HSK50A x EOC16 - 120	145	120	94	43	M12 x 1.75P	2 ~ 16	0.90
5072-121-025-100	HSK50A x EOC25 - 100	125	100	58	60	M16 x 2.0P	3 ~ 25	1.10
5072-121-025-120	HSK50A x EOC25 - 120	145	120	78	60	M16 x 2.0P	3 ~ 25	1.30
5072-121-025-150	HSK50A x EOC25 - 150	175	150	108	60	M16 x 2.0P	3 ~ 25	1.50
5072-121-032-120	HSK50A x EOC32 - 120	145	120	78	72	M20 x 2.0P	4 ~ 32	2.10
5072-121-032-150	HSK50A x EOC32 - 150	175	150	108	72	M20 x 2.0P	4 ~ 32	2.30
5073-121-016-100	HSK63A x EOC16 - 100	132	100	69	43	M12 x 1.75P	2 ~ 16	1.10
5073-121-016-120	HSK63A x EOC16 - 120	152	120	89	43	M12 x 1.75P	2 ~ 16	1.20
5073-121-025-100	HSK63A x EOC25 - 100	132	100	72	60	M16 x 2.0P	3 ~ 25	1.30
5073-121-025-120	HSK63A x EOC25 - 120	152	120	92	60	M16 x 2.0P	3 ~ 25	1.50
5073-121-025-150	HSK63A x EOC25 - 150	182	150	122	60	M16 x 2.0P	3 ~ 25	1.70
5073-121-032-120	HSK63A x EOC32 - 120	152	120	78	72	M20 x 2.0P	4 ~ 32	2.30
5073-121-032-150	HSK63A x EOC32 - 150	182	150	108	72	M20 x 2.0P	4 ~ 32	2.50
5075-121-016-100	HSK100A x EOC16 - 100	150	100	61	43	M12 x 1.75P	2.0 ~ 16	3.40
5075-121-016-120	HSK100A x EOC16 - 120	170	120	81	43	M12 x 1.75P	2.0 ~ 16	3.60
5075-121-025-100	HSK100A x EOC25 - 100	150	100	61	60	-	3.0 ~ 25	3.50
5075-121-025-120	HSK100A x EOC25 - 120	170	120	81	60	M16 x 2.0P	3.0 ~ 25	3.70
5075-121-025-150	HSK100A x EOC25 - 150	200	150	111	60	M16 x 2.0P	3.0 ~ 25	4.10
5075-121-032-130	HSK100A x EOC32 - 130	180	130	91	72	M20 x 2.0P	4.0 ~ 32	4.50
5075-121-032-150	HSK100A x EOC32 - 150	200	150	111	72	M20 x 2.0P	4.0 ~ 32	4.70

Features:

- ▶ Attached with POWER GOOD EOC clamping nuts, good clamping force, and suitable for heavy-duty machining.
- ▶ Used with ISO 10897 EOC and SYOZ collets.
- ▶ Standard tool kits of 7PC and 15PC are available.

Product information:

- ▶ Higher balancing grade and revolution can be done upon request but additional charge is needed.

Standard Accessory: • NUT

Collet	Nut	Coolant Supply Unit	Key	Spanner	Preset Screw
P.X-49	P.X-61	P.X-70	P.X-70	P.X-80	P.X-111



HSK / SAF RUNOUT ADJUSTABLE HOLDER

4.5°

HSK / SAF 可調式刀桿

[SFC TYPE]

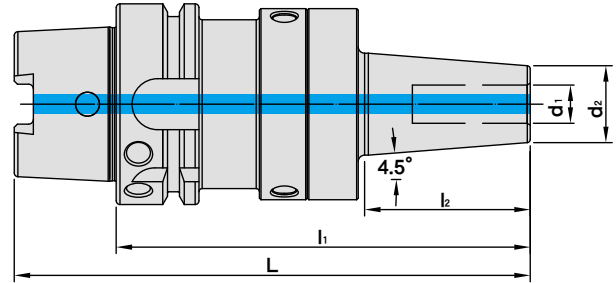

J P PAT NO. 3237773
 DE PAT NO. 202022102696
 CN PAT NO. ZL20221891039.3

MODEL NO.	TYPE	L	l ₁	l ₂	d ₁	d ₂	COMBINATION		WEIGHT (KGS)
							BODY	FLANGE ADAPTER	
5071-S27-006-130	HSK40A x SAF6C - 130	150	130	52	6	21	HSK40A x SAF25	SFC6 - 70	1.22
5071-S27-008-130	HSK40A x SAF8C - 130	150	130	52	8	21	HSK40A x SAF25	SFC8 - 70	1.21
5071-S27-010-130	HSK40A x SAF10C - 130	150	130	52	10	24	HSK40A x SAF25	SFC10 - 70	1.26
5071-S27-012-130	HSK40A x SAF12C - 130	150	130	52	12	24	HSK40A x SAF25	SFC12 - 70	1.24
5071-S27-016-135	HSK40A x SAF16C - 135	155	135	57	16	27	HSK40A x SAF25	SFC16 - 75	1.29
5072-S27-006-130	HSK50A x SAF6C - 130	155	130	52	6	21	HSK50A x SAF25	SFC6 - 70	1.34
5072-S27-008-130	HSK50A x SAF8C - 130	155	130	52	8	21	HSK50A x SAF25	SFC8 - 70	1.33
5072-S27-010-130	HSK50A x SAF10C - 130	155	130	52	10	24	HSK50A x SAF25	SFC10 - 70	1.38
5072-S27-012-130	HSK50A x SAF12C - 130	155	130	52	12	24	HSK50A x SAF25	SFC12 - 70	1.36
5072-S27-016-135	HSK50A x SAF16C - 135	160	135	57	16	27	HSK50A x SAF25	SFC16 - 75	1.41
5073-S27-006-130	HSK63A x SAF6C - 130	162	130	52	6	21	HSK63A x SAF25	SFC6 - 70	1.68
5073-S27-008-130	HSK63A x SAF8C - 130	162	130	52	8	21	HSK63A x SAF25	SFC8 - 70	1.67
5073-S27-010-130	HSK63A x SAF10C - 130	162	130	52	10	24	HSK63A x SAF25	SFC10 - 70	1.72
5073-S27-012-130	HSK63A x SAF12C - 130	162	130	52	12	24	HSK63A x SAF25	SFC12 - 70	1.70
5073-S27-016-135	HSK63A x SAF16C - 135	167	135	57	16	27	HSK63A x SAF25	SFC16 - 75	1.75
5073-S27-020-140	HSK63A x SAF20C - 140	172	140	60	20	33	HSK63A x SAF40	SFC20 - 80	2.55
5073-S27-025-160	HSK63A x SAF25C - 160	192	160	81	25	44	HSK63A x SAF40	SFC25 - 100	3.08
5073-S27-032-160	HSK63A x SAF32C - 160	192	160	81	32	44	HSK63A x SAF40	SFC32 - 100	2.94
5074-S27-006-120	HSK80A x SAF6C - 120	160	120	52	6	21	HSK80A x SAF25	SFC6 - 70	1.99
5074-S27-008-120	HSK80A x SAF8C - 120	160	120	52	8	21	HSK80A x SAF25	SFC8 - 70	1.98
5074-S27-010-120	HSK80A x SAF10C - 120	160	120	52	10	24	HSK80A x SAF25	SFC10 - 70	2.03
5074-S27-012-120	HSK80A x SAF12C - 120	160	120	52	12	24	HSK80A x SAF25	SFC12 - 70	2.01
5074-S27-016-125	HSK80A x SAF16C - 125	165	125	57	16	27	HSK80A x SAF25	SFC16 - 75	2.06
5074-S27-020-140	HSK80A x SAF20C - 140	180	140	60	20	33	HSK80A x SAF40	SFC20 - 80	3.14
5074-S27-025-160	HSK80A x SAF25C - 160	200	160	81	25	44	HSK80A x SAF40	SFC25 - 100	3.67
5074-S27-032-160	HSK80A x SAF32C - 160	200	160	81	32	44	HSK80A x SAF40	SFC32 - 100	3.53
5075-S27-006-125	HSK100A x SAF6C - 125	175	125	52	6	21	HSK100A x SAF25	SFC6 - 70	2.93
5075-S27-008-125	HSK100A x SAF8C - 125	175	125	52	8	21	HSK100A x SAF25	SFC8 - 70	2.92
5075-S27-010-125	HSK100A x SAF10C - 125	175	125	52	10	24	HSK100A x SAF25	SFC10 - 70	2.97
5075-S27-012-125	HSK100A x SAF12C - 125	175	125	52	12	24	HSK100A x SAF25	SFC12 - 70	2.95
5075-S27-016-130	HSK100A x SAF16C - 130	180	130	57	16	27	HSK100A x SAF25	SFC16 - 75	3.00
5075-S27-020-135	HSK100A x SAF20C - 135	185	135	60	20	33	HSK100A x SAF40	SFC20 - 80	3.92
5075-S27-025-155	HSK100A x SAF25C - 155	205	155	81	25	44	HSK100A x SAF40	SFC25 - 100	4.45
5075-S27-032-155	HSK100A x SAF32C - 155	205	155	81	32	44	HSK100A x SAF40	SFC32 - 100	4.31

Standard Accessory: • WRENCH (FOR ADJUSTMENT SCREW) • PIN

Coolant Supply Unit	Key	Shrink Fit Chuck Flange	Preset Screw
P.X-70	P.X-70	P.X-98	P.X-111

Features:

- ▶ The runout accuracy of tool edges can be adjusted within 5µm.
- ▶ Different output options to meet customer machining requirements.
- ▶ Suitable for reaming, drilling and milling.



HSK / SAF RUNOUT ADJUSTABLE HOLDER

HSK / SAF 可調式刀桿

[SK3 TYPE]

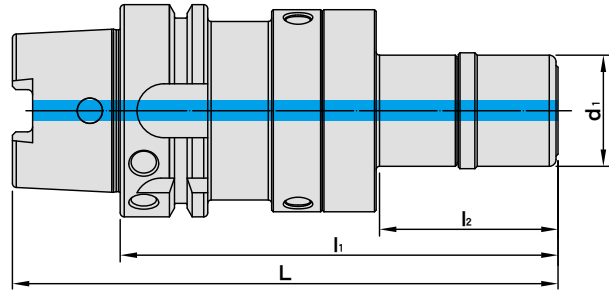

J P PAT NO. 3237773
DE PAT NO. 202022102696
CN PAT NO. ZL20221891039.3

MODEL NO.	TYPE	L	l ₁	l ₂	d ₁	COMBINATION		COLLET	WEIGHT (KGS)
						BODY	FLANGE ADAPTER		
5071-S28-006-110	HSK40A x SAF6K - 110	130	110	29	19.5	HSK40A x SAF25	SK306 - 50	SKX6	1.09
5071-S28-006-160	HSK40A x SAF6K - 160	180	160	79	19.5	HSK40A x SAF25	SK306 - 100	SKX6	1.18
5071-S28-010-110	HSK40A x SAF10K - 110	130	110	32.5	27.5	HSK40A x SAF25	SK310 - 50	SKX10	1.12
5071-S28-010-160	HSK40A x SAF10K - 160	180	160	82.5	27.5	HSK40A x SAF25	SK310 - 100	SKX10	1.31
5071-S28-013-130	HSK40A x SAF13K - 130	150	130	53	33	HSK40A x SAF25	SK313 - 70	SKX13	1.25
5071-S28-013-160	HSK40A x SAF13K - 160	180	160	83	33	HSK40A x SAF25	SK313 - 100	SKX13	1.43
5072-S28-006-110	HSK50A x SAF6K - 110	135	110	29	19.5	HSK50A x SAF25	SK306 - 50	SKX6	1.21
5072-S28-006-160	HSK50A x SAF6K - 160	185	160	79	19.5	HSK50A x SAF25	SK306 - 100	SKX6	1.30
5072-S28-010-110	HSK50A x SAF10K - 110	135	110	32.5	27.5	HSK50A x SAF25	SK310 - 50	SKX10	1.24
5072-S28-010-160	HSK50A x SAF10K - 160	185	160	82.5	27.5	HSK50A x SAF25	SK310 - 100	SKX10	1.43
5072-S28-013-130	HSK50A x SAF13K - 130	155	130	53	33	HSK50A x SAF25	SK313 - 70	SKX13	1.37
5072-S28-013-160	HSK50A x SAF13K - 160	185	160	83	33	HSK50A x SAF25	SK313 - 100	SKX13	1.55
5073-S28-006-110	HSK63A x SAF6K - 110	142	110	29	19.5	HSK63A x SAF25	SK306 - 50	SKX6	1.55
5073-S28-006-160	HSK63A x SAF6K - 160	192	160	79	19.5	HSK63A x SAF25	SK306 - 100	SKX6	1.64
5073-S28-010-110	HSK63A x SAF10K - 110	142	110	32.5	27.5	HSK63A x SAF25	SK310 - 50	SKX10	1.58
5073-S28-010-160	HSK63A x SAF10K - 160	192	160	82.5	27.5	HSK63A x SAF25	SK310 - 100	SKX10	1.77
5073-S28-013-130	HSK63A x SAF13K - 130	162	130	53	33	HSK63A x SAF25	SK313 - 70	SKX13	1.71
5073-S28-013-160	HSK63A x SAF13K - 160	192	160	83	33	HSK63A x SAF25	SK313 - 100	SKX13	1.89
5073-S28-016-130	HSK63A x SAF16K - 130	162	130	49.9	40	HSK63A x SAF40	SK316 - 70	SKX16	2.44
5073-S28-016-160	HSK63A x SAF16K - 160	192	160	79.9	40	HSK63A x SAF40	SK316 - 100	SKX16	2.70

Features:

- ▶ The runout accuracy of tool edges can be adjusted within 5µm.
- ▶ Different output options to meet customer machining requirements.
- ▶ Suitable for reaming, drilling and milling.

Standard Accessory: • NUT • WRENCH (FOR ADJUSTMENT SCREW) • PIN

Collet	Nut	Coolant Supply Unit	Key	Spanner	SK3 Collet Chuck Flange	Preset Screw
P.X-39~41	P.X-58	P.X-70	P.X-70	P.X-73、75、82	P.X-99	P.X-111



HSK / SAF RUNOUT ADJUSTABLE HOLDER

HSK / SAF 可調式刀桿

{SK3 TYPE}

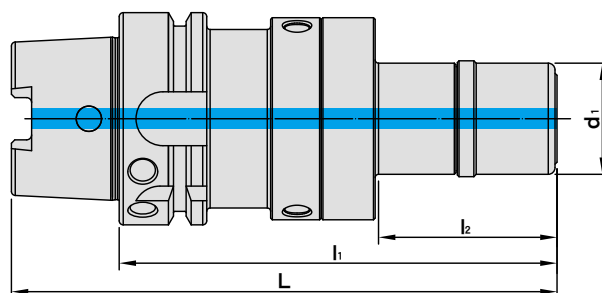

J P PAT NO. 3237773
 DE PAT NO. 202022102696
 CN PAT NO. ZL20221891039.3

MODEL NO.	TYPE	L	l ₁	l ₂	d ₁	COMBINATION		COLLET	WEIGHT (KGS)
						BODY	FLANGE ADAPTER		
5074-S28-006-100	HSK80A x SAF6K - 100	140	100	29	19.5	HSK80A x SAF25	SK306 - 50	SKX6	1.86
5074-S28-006-150	HSK80A x SAF6K - 150	190	150	79	19.5	HSK80A x SAF25	SK306 - 100	SKX6	1.95
5074-S28-010-100	HSK80A x SAF10K - 100	140	100	32.5	27.5	HSK80A x SAF25	SK310 - 50	SKX10	1.89
5074-S28-010-150	HSK80A x SAF10K - 150	190	150	82.5	27.5	HSK80A x SAF25	SK310 - 100	SKX10	2.08
5074-S28-013-120	HSK80A x SAF13K - 120	160	120	53	33	HSK80A x SAF25	SK313 - 70	SKX13	2.02
5074-S28-013-150	HSK80A x SAF13K - 150	190	150	83	33	HSK80A x SAF25	SK313 - 100	SKX13	2.20
5074-S28-016-130	HSK80A x SAF16K - 130	170	130	49.9	40	HSK80A x SAF40	SK316 - 70	SKX16	3.03
5074-S28-016-160	HSK80A x SAF16K - 160	200	160	79.9	40	HSK80A x SAF40	SK316 - 100	SKX16	3.29
5075-S28-006-105	HSK100A x SAF6K - 105	155	105	29	19.5	HSK100A x SAF25	SK306 - 50	SKX6	2.80
5075-S28-006-155	HSK100A x SAF6K - 155	205	155	79	19.5	HSK100A x SAF25	SK306 - 100	SKX6	2.89
5075-S28-010-105	HSK100A x SAF10K - 105	155	105	32.5	27.5	HSK100A x SAF25	SK310 - 50	SKX10	2.83
5075-S28-010-155	HSK100A x SAF10K - 155	205	155	82.5	27.5	HSK100A x SAF25	SK310 - 100	SKX10	3.02
5075-S28-013-125	HSK100A x SAF13K - 125	175	125	53	33	HSK100A x SAF25	SK313 - 70	SKX13	2.96
5075-S28-013-155	HSK100A x SAF13K - 155	205	155	83	33	HSK100A x SAF25	SK313 - 100	SKX13	3.14
5075-S28-016-125	HSK100A x SAF16K - 125	175	125	49.9	40	HSK100A x SAF40	SK316 - 70	SKX16	3.81
5075-S28-016-155	HSK100A x SAF16K - 155	205	155	79.9	40	HSK100A x SAF40	SK316 - 100	SKX16	4.07

Features:

- ▶ The runout accuracy of tool edges can be adjusted within 5µm.
- ▶ Different output options to meet customer machining requirements.
- ▶ Suitable for reaming, drilling and milling.

Standard Accessory: • NUT • WRENCH (FOR ADJUSTMENT SCREW) • PIN

Collet	Nut	Coolant Supply Unit	Key	Spanner	SK3 Collet Chuck Flange	Preset Screw
P.X-39~41	P.X-58	P.X-70	P.X-70	P.X-73、75、82	P.X-99	P.X-111



HSK / SAF RUNOUT ADJUSTABLE HOLDER



HSK / SAF 可調式刀桿

(UT TYPE)

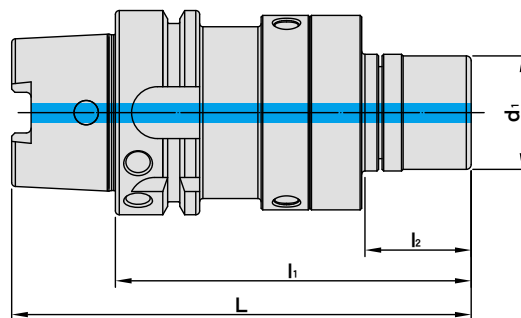

J P PAT NO. 3237773
DE PAT NO. 202022102696
CN PAT NO. ZL20221891039.3

MODEL NO.	TYPE	L	l ₁	l ₂	d ₁	COMBINATION		COLLET	WEIGHT (KGS)
						BODY	FLANGE ADAPTER		
5071-S30-016-110	HSK40A x SAF16U - 110	130	110	32	30	HSK40A x SAF25	UT16 - 50	ER16	1.17
5071-S30-020-110	HSK40A x SAF20U - 110	130	110	33	35	HSK40A x SAF25	UT20 - 50	ER20	1.19
5072-S30-016-110	HSK50A x SAF16U - 110	135	110	32	30	HSK50A x SAF25	UT16 - 50	ER16	1.29
5072-S30-020-110	HSK50A x SAF20U - 110	135	110	33	35	HSK50A x SAF25	UT20 - 50	ER20	1.31
5073-S30-016-110	HSK63A x SAF16U - 110	142	110	32	30	HSK63A x SAF25	UT16 - 50	ER16	1.63
5073-S30-020-110	HSK63A x SAF20U - 110	142	110	33	35	HSK63A x SAF25	UT20 - 50	ER20	1.65
5073-S30-025-120	HSK63A x SAF25U - 120	152	120	38.9	42	HSK63A x SAF40	UT25 - 60	ER25	2.45
5073-S30-032-120	HSK63A x SAF32U - 120	152	120	40.9	48	HSK63A x SAF40	UT32 - 60	ER32	2.48
5074-S30-016-100	HSK80A x SAF16U - 100	140	100	32	30	HSK80A x SAF25	UT16 - 50	ER16	1.94
5074-S30-020-100	HSK80A x SAF20U - 100	140	100	33	35	HSK80A x SAF25	UT20 - 50	ER20	1.96
5074-S30-025-120	HSK80A x SAF25U - 120	160	120	38.9	42	HSK80A x SAF40	UT25 - 60	ER25	3.04
5074-S30-032-120	HSK80A x SAF32U - 120	160	120	40.9	48	HSK80A x SAF40	UT32 - 60	ER32	3.07
5075-S30-016-105	HSK100A x SAF16U - 105	155	105	32	30	HSK100A x SAF25	UT16 - 50	ER16	2.88
5075-S30-020-105	HSK100A x SAF20U - 105	155	105	33	35	HSK100A x SAF25	UT20 - 50	ER20	2.90
5075-S30-025-115	HSK100A x SAF25U - 115	165	115	38.9	42	HSK100A x SAF40	UT25 - 60	ER25	3.82
5075-S30-032-115	HSK100A x SAF32U - 115	165	115	40.9	48	HSK100A x SAF40	UT32 - 60	ER32	3.85

Features:

- ▶ The runout accuracy of tool edges can be adjusted within 5µm.
- ▶ Different output options to meet customer machining requirements.
- ▶ Suitable for reaming, drilling and milling.

Standard Accessory: • NUT • WRENCH (FOR ADJUSTMENT SCREW) • PIN

Collet	Nut	Coolant Supply Unit	Key	Spanner	UT Collet Chuck Flange	Preset Screw
P.X-18~21	P.X-54	P.X-70	P.X-70	PX-73、75、82	P.X-100	P.X-111



SAF RUNOUT ADJUSTABLE HOLDER BODY

SAF 可調式刀桿本體

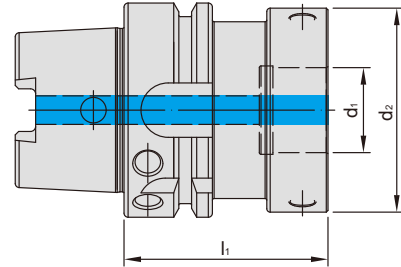

MODEL NO.	TYPE	l_1	d_2	SAF NO.	WEIGHT (KGS)
5071-783-025-060	HSK40A x SAF25 - 60	60	60	1	0.70
5072-783-025-060	HSK50A x SAF25 - 60	60	60	1	0.82
5073-783-025-060	HSK63A x SAF25 - 60	60	60	1	1.16
5073-783-040-060	HSK63A x SAF40 - 60	60	80	2	1.36
5074-783-025-050	HSK80A x SAF25 - 50	50	60	1	1.47
5074-783-040-060	HSK80A x SAF40 - 60	60	80	2	1.95
5075-783-025-055	HSK100A x SAF25 - 55	55	60	1	2.41
5075-783-040-055	HSK100A x SAF40 - 55	55	80	2	2.73

HSK / SBF RADIAL ZERO ADJUSTABLE HOLDER



HSK / SBF 可調式徑向歸零刀桿

[PRO-E TYPE]

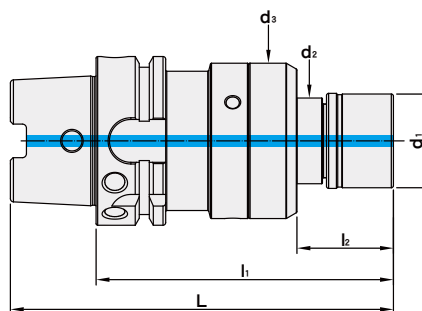

MODEL NO.	TYPE	L	l ₁	l ₂	d ₁	d ₂	d ₃	COLLET	WEIGHT (KGS)
5071-S10-016-160	HSK40A x SBF16PE - 160	180	160	92	30	32	58	ER16	1.37
5071-S10-020-110	HSK40A x SBF20PE - 110	130	110	42	35	32	58	ER20	1.07
5071-S10-020-160	HSK40A x SBF20PE - 160	180	160	92	35	32	58	ER20	1.38
5072-S10-016-110	HSK50A x SBF16PE - 110	135	110	37	30	32	58	ER16	1.27
5072-S10-016-160	HSK50A x SBF16PE - 160	185	160	87	30	32	58	ER16	1.57
5072-S10-020-110	HSK50A x SBF20PE - 110	135	110	37	35	32	58	ER20	1.28
5072-S10-020-160	HSK50A x SBF20PE - 160	185	160	87	35	32	58	ER20	1.58
5073-S10-016-110	HSK63A x SBF16PE - 110	142	110	37	30	32	58	ER16	1.62
5073-S10-016-160	HSK63A x SBF16PE - 160	192	160	87	30	32	58	ER16	1.91
5073-S10-020-110	HSK63A x SBF20PE - 110	142	110	37	35	32	58	ER20	1.63
5073-S10-020-160	HSK63A x SBF20PE - 160	192	160	87	35	32	58	ER20	1.92
5073-S10-025-110	HSK63A x SBF25PE - 110	142	110	32	42	42	75	ER25	2.18
5073-S10-025-160	HSK63A x SBF25PE - 160	192	160	82	42	42	75	ER25	2.70
5073-S10-032-120	HSK63A x SBF32PE - 120	152	120	42	50	42	75	ER32	2.24
5073-S10-032-160	HSK63A x SBF32PE - 160	192	160	82	50	42	75	ER32	2.70

Features:

- ▶ Suitable for reaming and drilling.
- ▶ Improve the surface accuracy of workpiece.
- ▶ Ensure the machining stability in hole making.
- ▶ Compensate for bad runout accuracy generated from machine spindle, tool holder and cutter, adjust runout accuracy to be within 2µm and extend tool use life.
- ▶ Simple and quick to adjust by 3 screws.
- ▶ Center coolant through is available and can be up to 70 bar.

Standard Accessory: • NUT • WRENCH (FOR ADJUSTMENT SCREW) • PIN

Collet	Nut	Coolant Supply Unit	Key	Spanner	Preset Screw
P.X-18~32	P.X-53	P.X-70	P.X-70	P.X-73、75、82	P.X-111



HSK / SBF RADIAL ZERO ADJUSTABLE HOLDER



HSK / SBF 可調式徑向歸零刀桿

[PRO-E TYPE]

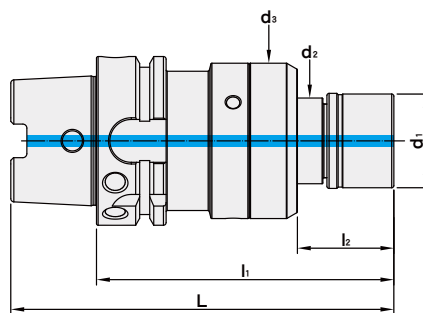

MODEL NO.	TYPE	L	l ₁	l ₂	d ₁	d ₂	d ₃	COLLET	WEIGHT (KGS)
5074-S10-016-100	HSK80A x SBF16PE - 100	140	100	44	30	32	58	ER16	1.82
5074-S10-016-150	HSK80A x SBF16PE - 150	190	150	94	30	32	58	ER16	2.10
5074-S10-020-100	HSK80A x SBF20PE - 100	140	100	44	35	32	58	ER20	1.83
5074-S10-020-150	HSK80A x SBF20PE - 150	190	150	94	35	32	58	ER20	2.11
5074-S10-025-110	HSK80A x SBF25PE - 110	150	110	32	42	42	75	ER25	2.83
5074-S10-025-160	HSK80A x SBF25PE - 160	200	160	82	42	42	75	ER25	3.34
5074-S10-032-120	HSK80A x SBF32PE - 120	160	120	42	50	42	75	ER32	2.88
5074-S10-032-160	HSK80A x SBF32PE - 160	200	160	82	50	42	75	ER32	3.34
5075-S10-016-105	HSK100A x SBF16PE - 105	155	105	47	30	32	58	ER16	2.72
5075-S10-016-155	HSK100A x SBF16PE - 155	205	155	97	30	32	58	ER16	2.30
5075-S10-020-105	HSK100A x SBF20PE - 105	200	150	47	35	32	58	ER20	2.73
5075-S10-020-155	HSK100A x SBF20PE - 155	205	155	97	35	32	58	ER20	3.01
5075-S10-025-105	HSK100A x SBF25PE - 105	155	105	42	42	42	75	ER25	3.34
5075-S10-025-155	HSK100A x SBF25PE - 155	205	155	92	42	42	75	ER25	3.83
5075-S10-032-115	HSK100A x SBF32PE - 115	165	115	52	50	42	75	ER32	3.41
5075-S10-032-155	HSK100A x SBF32PE - 155	205	155	92	50	42	75	ER32	3.83

Features:

- ▶ Suitable for reaming and drilling.
- ▶ Improve the surface accuracy of workpiece.
- ▶ Ensure the machining stability in hole making.
- ▶ Compensate for bad runout accuracy generated from machine spindle, tool holder and cutter, adjust runout accuracy to be within 2µm and extend tool use life.
- ▶ Simple and quick to adjust by 3 screws.
- ▶ Center coolant through is available and can be up to 70 bar.

Standard Accessory: • NUT • WRENCH (FOR ADJUSTMENT SCREW) • PIN

Collet	Nut	Coolant Supply Unit	Key	Spanner	Preset Screw
P.X-18~32	P.X-53	P.X-70	P.X-70	P.X-73、75、82	P.X-111



HSK / SLN SIDE LOCK END MILL HOLDER

HSK / SLN 側固式立銑刀桿

(DIN 1835-B)
(DIN 69882-4)

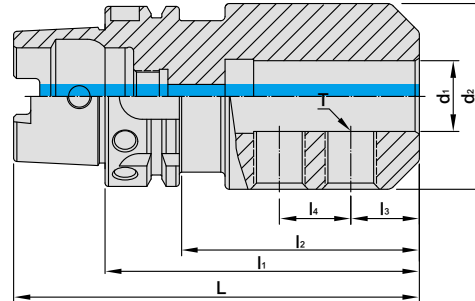

MODEL NO.	TYPE	L	l ₁	l ₂	l ₃	l ₄	d ₁	d ₂	T	WEIGHT (KGS)
5072-653-006-065	HSK50A x SLN6 - 65	90	65	34	18	-	6	25	M6 x 1.0P	0.70
5072-653-008-065	HSK50A x SLN8 - 65	90	65	36	18	-	8	28	M8 x 1.25P	0.80
5072-653-010-065	HSK50A x SLN10 - 65	90	65	36.5	20	-	10	35	M10 x 1.5P	0.80
5072-653-012-080	HSK50A x SLN12 - 80	105	80	53.5	22.5	-	12	42	M12 x 1.75P	1.20
5072-653-014-080	HSK50A x SLN14 - 80	105	80	53.5	22.5	-	14	44	M12 x 1.75P	1.30
5072-653-016-080	HSK50A x SLN16 - 80	105	80	53.5	24	-	16	48	M14 x 2.0P	1.30
5072-653-018-080	HSK50A x SLN18 - 80	105	80	53.5	24	-	18	50	M14 x 2.0P	1.40
5072-653-020-080	HSK50A x SLN20 - 80	105	80	53	25	-	20	52	M16 x 2.0P	1.50
5073-653-006-065	HSK63A x SLN6 - 65	97	65	36	18	-	6	25	M6 x 1.0P	0.90
5073-653-008-065	HSK63A x SLN8 - 65	97	65	36	18	-	8	28	M8 x 1.25P	1.00
5073-653-010-065	HSK63A x SLN10 - 65	97	65	36	20	-	10	35	M10 x 1.5P	1.00
5073-653-012-080	HSK63A x SLN12 - 80	112	80	49	22.5	-	12	42	M12 x 1.75P	1.70
5073-653-014-080	HSK63A x SLN14 - 80	112	80	51	22.5	-	14	44	M12 x 1.75P	1.70
5073-653-016-080	HSK63A x SLN16 - 80	112	80	51.5	24	-	16	48	M14 x 2.0P	1.70
5073-653-018-080	HSK63A x SLN18 - 80	112	80	52.5	24	-	18	50	M14 x 2.0P	1.80
5073-653-020-080	HSK63A x SLN20 - 80	112	80	53.5	25	-	20	52	M16 x 2.0P	1.80
5073-653-025-110	HSK63A x SLN25 - 110	142	110	83.2	24	25	25	65	M18 x 2.0P	2.50
5073-653-032-110	HSK63A x SLN32 - 110	142	110	83.2	24	28	32	72	M20 x 2.0P	2.70
5075-653-006-080	HSK100A x SLN6 - 80	130	80	41	18	-	6	25	M6 x 1.0P	3.00
5075-653-008-080	HSK100A x SLN8 - 80	130	80	41	18	-	8	28	M8 x 1.25P	3.20
5075-653-010-080	HSK100A x SLN10 - 80	130	80	46	20	-	10	35	M10 x 1.5P	3.40
5075-653-012-080	HSK100A x SLN12 - 80	130	80	46	22.5	-	12	42	M12 x 1.75P	3.40
5075-653-014-080	HSK100A x SLN14 - 80	130	80	46	22.5	-	14	44	M12 x 1.75P	3.50
5075-653-016-100	HSK100A x SLN16 - 100	150	100	66	24	-	16	48	M14 x 2.0P	3.80
5075-653-018-100	HSK100A x SLN18 - 100	150	100	66	24	-	18	50	M16 x 2.0P	3.80
5075-653-020-100	HSK100A x SLN20 - 100	150	100	61	25	-	20	52	M16 x 2.0P	3.90
5075-653-025-100	HSK100A x SLN25 - 100	150	100	66	24	25	25	65	M18 x 2.0P	4.00
5075-653-025-120	HSK100A x SLN25 - 120	170	120	91	24	25	25	65	M18 x 2.0P	3.85
5075-653-032-100	HSK100A x SLN32 - 100	150	100	66	24	28	32	72	M20 x 2.0P	4.10
5075-653-040-120	HSK100A x SLN40 - 120	170	120	89	30	32	40	90	M20 x 2.0P	4.40

Features:

- ▶ Internal hole tolerance: H5 (DIN-1835-B standard).
- ▶ The tolerance requirement of tool shank diameter is h6.
- ▶ Taking use of side lock screws to clamp tools with lateral flat surfaces. Good at heavy-duty machining.

Product information:

- ▶ The pre-balance reaches G6.3 8,000 rpm. Higher balancing grade and revolution can be done upon request but additional charge is needed.

Standard Accessory: • LOCK SCREW

Coolant Supply Unit	Key	Lock Screw
		
P.X-70	P.X-70	P.X-113



HSK / SLN SIDE LOCK END MILL HOLDER

HSK / SLN 側固式立銑刀桿

(DIN 1835-B)
(DIN 69882-4)

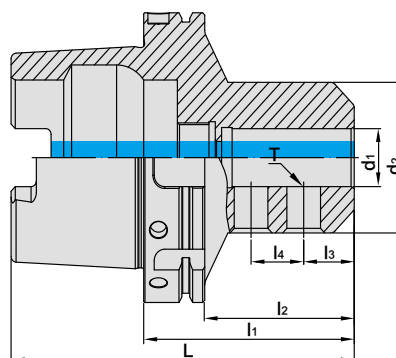

MODEL NO.	TYPE	L	l ₁	l ₂	l ₃	l ₄	d ₁	d ₂	T	WEIGHT (KGS)
5076-653-010-085	HSK125A x SLN10 - 85	148	85	41.5	20	-	10	35	M10 x 1.5P	4.20
5076-653-012-090	HSK125A x SLN12 - 90	153	90	51	22.5	-	12	42	M12 x 1.75P	4.30
5076-653-014-090	HSK125A x SLN14 - 90	153	90	51	22.5	-	14	44	M12 x 1.75P	4.30
5076-653-016-095	HSK125A x SLN16 - 95	158	95	56	24	-	16	48	M14 x 2.0P	4.50
5076-653-020-095	HSK125A x SLN20 - 95	158	95	56	25	-	20	52	M16 x 2.0P	4.60
5076-653-025-100	HSK125A x SLN25 - 100	163	100	66	24	25	25	65	M18 x 2.0P	4.90
5076-653-032-105	HSK125A x SLN32 - 105	168	105	71	24	28	32	72	M20 x 2.0P	5.30
5076-653-040-120	HSK125A x SLN40 - 120	183	120	86	30	32	40	90	M20 x 2.0P	6.85
5076-653-050-130	HSK125A x SLN50 - 130	193	130	96	35	35	50	98	M24 x 2.0P	7.55

Features:

- ▶ Internal hole tolerance: H5 (DIN-1835-B standard).
- ▶ The tolerance requirement of tool shank diameter is h6.
- ▶ Taking use of side lock screws to clamp tools with lateral flat surfaces. Good at heavy-duty machining.

Product information:

- ▶ The pre-balance reaches G6.3 8,000 rpm. Higher balancing grade and revolution can be done upon request but additional charge is needed.

Standard Accessory: • LOCK SCREW

Coolant Supply Unit	Key	Lock Screw
		
P.X-70	P.X-70	P.X-113



HSK / SLN SIDE LOCK END MILL HOLDER

HSK / SLN 側固式立銑刀桿

(DIN 1835-B)

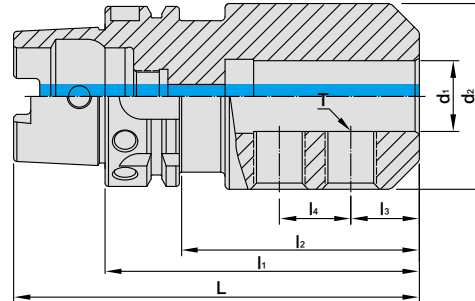

INCHES

MODEL NO.	TYPE	L	l ₁	l ₂	l ₃	l ₄	d ₁	d ₂	T	WEIGHT (KGS)
5071-653-A16-250	HSK40A x SLN1/4" - 2.5"	3.287	2.5	1.516	0.63	-	0.25	0.78	1/4 - 28	0.31
5071-653-A24-250	HSK40A x SLN3/8" - 2.5"	3.287	2.5	1.594	0.75	-	0.375	1	3/8 - 24	0.42
5071-653-A32-275	HSK40A x SLN1/2" - 2.75"	3.537	2.75	1.923	0.875	-	0.5	1.38	7/16 - 20	0.57
5071-653-A40-300	HSK40A x SLN5/8" - 3"	3.787	3	2.181	0.937	-	0.625	1.63	1/2 - 20	0.69
5073-653-A16-300	HSK63A x SLN1/4" - 3"	4.26	3	1.78	0.63	-	0.25	0.78	1/4 - 28	0.76
5073-653-A24-300	HSK63A x SLN3/8" - 3"	4.26	3	1.78	0.75	-	0.375	1	3/8 - 24	0.88
5073-653-A32-300	HSK63A x SLN1/2" - 3"	4.26	3	1.78	0.875	-	0.5	1.38	7/16 - 20	1.13
5073-653-A40-375	HSK63A x SLN5/8" - 3.75"	5	3.75	2.53	0.937	-	0.625	1.63	1/2 - 20	1.26
5073-653-A48-375	HSK63A x SLN3/4" - 3.75"	5	3.75	2.648	1	-	0.75	1.75	5/8 - 18	1.33
5073-653-A64-375	HSK63A x SLN1" - 3.75"	5	3.75	2.687	1.125	1	1	2	3/4 - 16	2.30
5073-653-A72-425	HSK63A x SLN1-1/4" - 4.25"	5.51	4.25	3.187	1.125	1	1.25	2.5	3/4 - 16	2.52
5075-653-A16-300	HSK100A x SLN1/4" - 3"	4.97	3	1.465	0.63	-	0.25	0.78	1/4 - 28	2.16
5075-653-A24-300	HSK100A x SLN3/8" - 3"	4.97	3	1.661	0.75	-	0.375	1	3/8 - 24	2.31
5075-653-A32-325	HSK100A x SLN1/2" - 3.25"	5.219	3.25	1.911	0.875	-	0.5	1.38	7/16 - 20	2.45
5075-653-A40-375	HSK100A x SLN5/8" - 3.75"	5.719	3.75	2.411	0.937	-	0.625	1.63	1/2 - 20	2.84
5075-653-A48-375	HSK100A x SLN3/4" - 3.75"	5.719	3.75	2.411	1	-	0.75	1.75	5/8 - 18	2.95
5075-653-A64-425	HSK100A x SLN1" - 4.25"	6.219	4.25	2.911	1.125	1	1	2	3/4 - 16	3.46
5075-653-A72-425	HSK100A x SLN1-1/4" - 4.25"	6.219	4.25	2.911	1.125	1	1.25	2.5	3/4 - 16	3.73
5075-653-A80-450	HSK100A x SLN1-1/2" - 4.5"	6.469	4.5	3.161	1.125	1	1.5	2.5	3/4 - 16	5.51
5075-653-A96-550	HSK100A x SLN2" - 5.5"	7.469	5.5	4.319	1.41	1.5	2	3.75	1 - 14	6.37

Features:

- ▶ Internal hole tolerance: H5 (DIN-1835-B standard).
- ▶ The tolerance requirement of tool shank diameter is h6.
- ▶ Taking use of side lock screws to clamp tools with lateral flat surfaces. Good at heavy-duty machining.

Product information:

- ▶ The pre-balance reaches G6.3 8,000 rpm. Higher balancing grade and revolution can be done upon request but additional charge is needed.

Standard Accessory: • LOCK SCREW

Coolant Supply Unit	Key	Lock Screw
 P.X-70	 P.X-70	 P.X-113



HSK / SLN SIDE LOCK END MILL HOLDER

JIS TYPE

HSK / SLN 側固式立銑刀桿 [JIS 型]

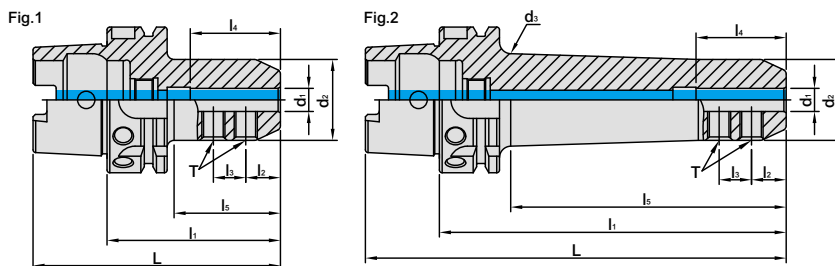

MODEL NO.	TYPE	L	l ₁	l ₂	l ₃	l ₄	l ₅	d ₁	d ₂	d ₃	T	Fig.	WEIGHT (KGS)
5073-654-010-075	HSK63A x SLN10 - 75JIS	107	75	15	14	39	46	10	35	-	M10 x 1.5P	1	0.94
5073-654-010-150	HSK63A x SLN10 - 150JIS	182	150	15	14	39	119	10	35	40	M10 x 1.5P	2	1.56
5073-654-012-080	HSK63A x SLN12 - 80JIS	112	80	20	16	44	51	12	42	-	M10 x 1.5P	1	1.12
5073-654-012-150	HSK63A x SLN12 - 150JIS	182	150	20	16	44	121	12	42	47	M10 x 1.5P	2	1.94
5073-654-016-090	HSK63A x SLN16 - 90JIS	122	90	22	18	47	62	16	48	-	M10 x 1.5P	1	1.38
5073-654-016-150	HSK63A x SLN16 - 150JIS	182	150	22	18	47	123	16	48	53	M10 x 1.5P	2	2.31
5073-654-020-090	HSK63A x SLN20 - 90JIS	122	90	25	20	55	62.5	20	50	-	M12 x 1.75P	1	1.41
5073-654-020-150	HSK63A x SLN20 - 150JIS	182	150	25	20	55	123	20	50	53	M12 x 1.75P	2	2.35
5073-654-025-090	HSK63A x SLN25 - 90JIS	122	90	24	25	58	62.5	25	50	-	M12 x 1.75P	1	1.31
5073-654-025-150	HSK63A x SLN25 - 150JIS	182	150	24	25	58	123	25	50	53	M12 x 1.75P	2	2.25
5073-654-032-105	HSK63A x SLN32 - 105JIS	137	105	24	28	63	79	32	60	-	M16 x 2.0P	1	1.73
5074-654-032-105	HSK80A x SLN32 - 105JIS	145	105	24	28	63	76	32	60	-	M16 x 2.0P	1	2.22



Features:

- ▶ Internal hole tolerance: H5.
- ▶ The tolerance requirement of tool shank diameter is h6.
- ▶ Taking use of side lock screws to clamp tools with lateral flat surfaces. Good at heavy-duty machining
- ▶ JIS type: standard length is longer than DIN type; types from SLN20 to SLN32 have smaller d2 OD dimensions than DIN type to avoid interference.

Product information:

- ▶ The pre-balance reaches G6.3 8,000 rpm. Higher balancing grade and revolution can be done upon request but additional charge is needed.

Standard Accessory: • LOCK SCREW

Coolant Supply Unit	Key	Lock Screw
		
P.X-70	P.X-70	P.X-113



HSK / SLN SIDE LOCK END MILL HOLDER

FID TYPE

HSK / SLN 側固式立銑刀桿 [FID 型]

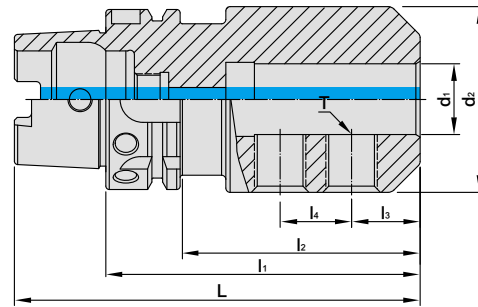

MODEL NO.	TYPE	L	l ₁	l ₂	l ₃	l ₄	d ₁	d ₂	T	WEIGHT (KGS)
5072-S35-006-065	HSK50A x SLN6 - 65 - FID	90	65	34	18	-	6	25	M6 x 1.0P	0.70
5072-S35-008-065	HSK50A x SLN8 - 65 - FID	90	65	36	18	-	8	28	M8 x 1.25P	0.80
5072-S35-010-065	HSK50A x SLN10 - 65 - FID	90	65	36.5	20	-	10	35	M10 x 1.5P	0.80
5072-S35-012-080	HSK50A x SLN12 - 80 - FID	105	80	53.5	22.5	-	12	42	M12 x 1.75P	1.20
5072-S35-014-080	HSK50A x SLN14 - 80 - FID	105	80	53.5	22.5	-	14	44	M12 x 1.75P	1.30
5072-S35-016-080	HSK50A x SLN16 - 80 - FID	105	80	53.5	24	-	16	48	M14 x 2.0P	1.30
5072-S35-018-080	HSK50A x SLN18 - 80 - FID	105	80	53.5	24	-	18	50	M14 x 2.0P	1.40
5072-S35-020-080	HSK50A x SLN20 - 80 - FID	105	80	53	25	-	20	52	M16 x 2.0P	1.50
5073-S35-006-065	HSK63A x SLN6 - 65 - FID	97	65	36	18	-	6	25	M6 x 1.0P	0.90
5073-S35-008-065	HSK63A x SLN8 - 65 - FID	97	65	36	18	-	8	28	M8 x 1.25P	1.00
5073-S35-010-065	HSK63A x SLN10 - 65 - FID	97	65	36	20	-	10	35	M10 x 1.5P	1.00
5073-S35-012-080	HSK63A x SLN12 - 80 - FID	112	80	49	22.5	-	12	42	M12 x 1.75P	1.70
5073-S35-014-080	HSK63A x SLN14 - 80 - FID	112	80	51	22.5	-	14	44	M12 x 1.75P	1.70
5073-S35-016-080	HSK63A x SLN16 - 80 - FID	112	80	51.5	24	-	16	48	M14 x 2.0P	1.70
5073-S35-018-080	HSK63A x SLN18 - 80 - FID	112	80	52.5	24	-	18	50	M14 x 2.0P	1.80
5073-S35-020-080	HSK63A x SLN20 - 80 - FID	112	80	53.5	25	-	20	52	M16 x 2.0P	1.80
5073-S35-025-110	HSK63A x SLN25 - 110 - FID	142	110	83.2	24	25	25	65	M18 x 2.0P	2.50
5073-S35-032-110	HSK63A x SLN32 - 110 - FID	142	110	83.2	24	28	32	72	M20 x 2.0P	2.70

Features:

- ▶ Internal hole tolerance: H5 (DIN-1835-B standard).
- ▶ The tolerance requirement of tool shank diameter is h6.
- ▶ Taking use of side lock screws to clamp tools with lateral flat surfaces. Good at heavy-duty machining.
- ▶ FID type: two coolant flutes enable coolant on tool path, no need for expensive coolant-thru tools.

Product information:

- ▶ The pre-balance reaches G6.3 8,000 rpm. Higher balancing grade and revolution can be done upon request but additional charge is needed.

Standard Accessory: • LOCK SCREW

Coolant Supply Unit	Key	Lock Screw
		
P.X-70	P.X-70	P.X-113



HSK / SLN SIDE LOCK END MILL HOLDER

FID TYPE

HSK / SLN 側固式立銑刀桿 [FID 型]

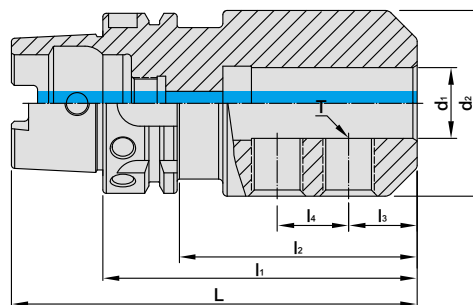

MODEL NO.	TYPE	L	l ₁	l ₂	l ₃	l ₄	d ₁	d ₂	T	WEIGHT (KGS)
5075-S35-006-080	HSK100A x SLN6 - 80 - FID	130	80	41	18	-	6	25	M6 x 1.0P	3.00
5075-S35-008-080	HSK100A x SLN8 - 80 - FID	130	80	41	18	-	8	28	M8 x 1.25P	3.20
5075-S35-010-080	HSK100A x SLN10 - 80 - FID	130	80	46	20	-	10	35	M10 x 1.5P	3.40
5075-S35-012-080	HSK100A x SLN12 - 80 - FID	130	80	46	22.5	-	12	42	M12 x 1.75P	3.40
5075-S35-014-080	HSK100A x SLN14 - 80 - FID	130	80	46	22.5	-	14	44	M12 x 1.75P	3.50
5075-S35-016-100	HSK100A x SLN16 - 100 - FID	150	100	66	24	-	16	48	M14 x 2.0P	3.80
5075-S35-018-100	HSK100A x SLN18 - 100 - FID	150	100	66	24	-	18	50	M16 x 2.0P	3.80
5075-S35-020-100	HSK100A x SLN20 - 100 - FID	150	100	61	25	-	20	52	M16 x 2.0P	3.90
5075-S35-025-100	HSK100A x SLN25 - 100 - FID	150	100	66	24	25	25	65	M18 x 2.0P	4.00
5075-S35-032-100	HSK100A x SLN32 - 100 - FID	150	100	66	24	28	32	72	M20 x 2.0P	4.10
5075-S35-040-120	HSK100A x SLN40 - 120 - FID	170	120	89	30	32	40	90	M20 x 2.0P	4.40
5076-S35-010-085	HSK125A x SLN10 - 85 - FID	148	85	35	20	-	10	35	M10 x 1.5P	4.20
5076-S35-012-090	HSK125A x SLN12 - 90 - FID	153	90	40	22.5	-	12	42	M12 x 1.75P	4.30
5076-S35-014-090	HSK125A x SLN14 - 90 - FID	153	90	40	22.5	-	14	44	M12 x 1.75P	4.30
5076-S35-016-095	HSK125A x SLN16 - 95 - FID	158	95	45	24	-	16	48	M14 x 2.0P	4.50
5076-S35-020-095	HSK125A x SLN20 - 95 - FID	158	95	45	25	-	20	52	M16 x 2.0P	4.60
5076-S35-025-100	HSK125A x SLN25 - 100 - FID	163	100	60	24	25	25	65	M18 x 2.0P	4.90
5076-S35-032-105	HSK125A x SLN32 - 105 - FID	168	105	65	24	28	32	72	M20 x 2.0P	5.30
5076-S35-040-120	HSK125A x SLN40 - 120 - FID	183	120	80	30	32	40	90	M20 x 2.0P	6.85
5076-S35-050-130	HSK125A x SLN50 - 130 - FID	193	130	90	35	35	50	98	M24 x 2.0P	7.55



Features:

- ▶ Internal hole tolerance: H5 (DIN-1835-B standard).
- ▶ The tolerance requirement of tool shank diameter is h6.
- ▶ Taking use of side lock screws to clamp tools with lateral flat surfaces. Good at heavy-duty machining.
- ▶ FID type: two coolant flutes enable coolant on tool path, no need for expensive coolant-thru tools.

Product information:

- ▶ The pre-balance reaches G6.3 8,000 rpm. Higher balancing grade and revolution can be done upon request but additional charge is needed.

Standard Accessory: • LOCK SCREW

Coolant Supply Unit	Key	Lock Screw
 P.X-70	 P.X-70	 P.X-113



HSK / SLN SIDE LOCK END MILL HOLDER

JIS-FID TYPE

HSK / SLN 側固式立銑刀桿 [JIS-FID 型]

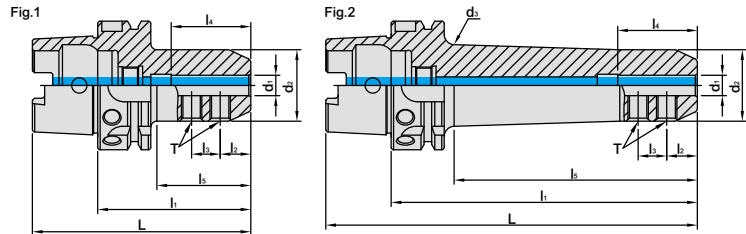

MODEL NO.	TYPE	L	l ₁	l ₂	l ₃	l ₄	l ₅	d ₁	d ₂	d ₃	T	Fig.	WEIGHT (KGS)
5073-S34-010-075	HSK63A x SLN10 - 75JIS - FID	107	75	15	14	39	46	10	35	-	M10 x 1.5P	1	0.94
5073-S34-010-150	HSK63A x SLN10 - 150JIS - FID	182	150	15	14	39	119	10	35	40	M10 x 1.5P	2	1.56
5073-S34-012-080	HSK63A x SLN12 - 80JIS - FID	112	80	20	16	44	51	12	42	-	M10 x 1.5P	1	1.12
5073-S34-012-150	HSK63A x SLN12 - 150JIS - FID	182	150	20	16	44	121	12	42	47	M10 x 1.5P	2	1.94
5073-S34-016-090	HSK63A x SLN16 - 90JIS - FID	122	90	22	18	47	62	16	48	-	M10 x 1.5P	1	1.38
5073-S34-016-150	HSK63A x SLN16 - 150JIS - FID	182	150	22	18	47	123	16	48	53	M10 x 1.5P	2	2.31
5073-S34-020-090	HSK63A x SLN20 - 90JIS - FID	122	90	25	20	55	62.5	20	50	-	M12 x 1.75P	1	1.41
5073-S34-020-150	HSK63A x SLN20 - 150JIS - FID	182	150	25	20	55	123	20	50	53	M12 x 1.75P	2	2.35
5073-S34-025-090	HSK63A x SLN25 - 90JIS - FID	122	90	24	25	58	62.5	25	50	-	M12 x 1.75P	1	1.31
5073-S34-025-150	HSK63A x SLN25 - 150JIS - FID	182	150	24	25	58	123	25	50	53	M12 x 1.75P	2	2.25
5073-S34-032-105	HSK63A x SLN32 - 105JIS - FID	137	105	24	28	63	79	32	60	-	M16 x 2.0P	1	1.73

Features:

- ▶ Internal hole tolerance: H5.
- ▶ The tolerance requirement of tool shank diameter is h6.
- ▶ Taking use of side lock screws to clamp tools with lateral flat surfaces. Good at heavy-duty machining.
- ▶ JIS type: standard length is longer than DIN type; types from SLN20 to SLN32 have smaller d2 OD dimensions than DIN type to avoid interference.
- ▶ FID type: two coolant flutes enable coolant on tool path, no need for expensive coolant-thru tools.

Product information:

- ▶ The pre-balance reaches G6.3 8,000 rpm. Higher balancing grade and revolution can be done upon request but additional charge is needed.

Standard Accessory: • LOCK SCREW

Coolant Supply Unit	Key	Lock Screw
		
P.X-70	P.X-70	P.X-113



HSK / SLNB SIDE LOCK END MILL HOLDER

HSK / SLNB 側固式立銑刀桿

(DIN 1835-E)
(DIN 69882-5)

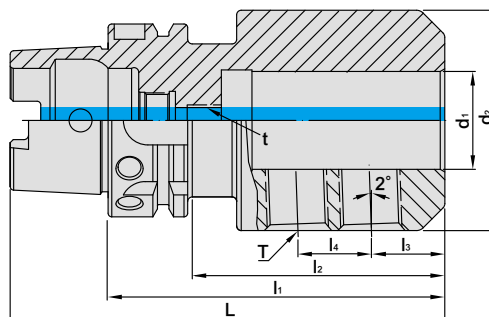

MODEL NO.	TYPE	L	l ₁	l ₂	l ₃	l ₄	d ₁	d ₂	t	T	WEIGHT (KGS)
5072-S50-006-080	HSK50A x SLNB6 - 80	105	80	49	18	-	6	25	M5	M6 x 1.0P	0.80
5072-S50-008-080	HSK50A x SLNB8 - 80	105	80	49	18	-	8	28	M6	M8 x 1.25P	0.90
5072-S50-010-080	HSK50A x SLNB10 - 80	105	80	51	20	-	10	35	M8	M10 x 1.5P	0.90
5072-S50-012-090	HSK50A x SLNB12 - 90	115	90	64	22.5	-	12	42	M10	M12 x 1.75P	1.30
5072-S50-014-090	HSK50A x SLNB14 - 90	115	90	63.2	22.5	-	14	44	M10	M12 x 1.75P	1.40
5072-S50-016-090	HSK50A x SLNB16 - 90	115	90	63.2	24	-	16	48	M12	M14 x 2.0P	1.40
5072-S50-018-090	HSK50A x SLNB18 - 90	115	90	63.2	24	-	18	50	M12	M14 x 2.0P	1.60
5072-S50-020-100	HSK50A x SLNB20 - 100	125	100	73	25	-	20	52	M16	M16 x 2.0P	1.70
5073-S50-006-080	HSK63A x SLNB6 - 80	112	80	49	18	-	6	25	M5	M6 x 1.0P	1.00
5073-S50-008-080	HSK63A x SLNB8 - 80	112	80	49	18	-	8	28	M6	M8 x 1.25P	1.10
5073-S50-010-080	HSK63A x SLNB10 - 80	112	80	51	20	-	10	35	M8	M10 x 1.5P	1.10
5073-S50-012-090	HSK63A x SLNB12 - 90	122	90	64	22.5	-	12	42	M10	M12 x 1.75P	2.00
5073-S50-014-090	HSK63A x SLNB14 - 90	122	90	61	22.5	-	14	44	M10	M12 x 1.75P	2.00
5073-S50-016-100	HSK63A x SLNB16 - 100	132	100	72	24	-	16	48	M12	M14 x 2.0P	2.00
5073-S50-018-100	HSK63A x SLNB18 - 100	132	100	72.5	24	-	18	50	M12	M14 x 2.0P	2.10
5073-S50-020-100	HSK63A x SLNB20 - 100	132	100	72.5	25	-	20	52	M16	M16 x 2.0P	2.10
5073-S50-025-110	HSK63A x SLNB25 - 110	142	110	83.2	24	25	25	65	M20	M18 x 2.0P	2.60
5073-S50-032-110	HSK63A x SLNB32 - 110	142	110	82.5	24	24	32	72	-	M20 x 2.0P	2.80
5075-S50-006-090	HSK100A x SLNB6 - 90	140	90	51	18	-	6	25	M5	M6 x 1.0P	3.40
5075-S50-008-090	HSK100A x SLNB8 - 90	140	90	51	18	-	8	28	M6	M8 x 1.25P	3.50
5075-S50-010-090	HSK100A x SLNB10 - 90	140	90	51	20	-	10	35	M8	M10 x 1.5P	3.80
5075-S50-012-100	HSK100A x SLNB12 - 100	150	100	61	22.5	-	12	42	M10	M12 x 1.75P	3.80
5075-S50-014-100	HSK100A x SLNB14 - 100	150	100	61	22.5	-	14	44	M10	M12 x 1.75P	4.00
5075-S50-016-100	HSK100A x SLNB16 - 100	150	100	66	24	-	16	48	M12	M14 x 2.0P	4.00
5075-S50-018-100	HSK100A x SLNB18 - 100	150	100	61	24	-	18	50	M12	M14 x 2.0P	4.00
5075-S50-020-110	HSK100A x SLNB20 - 110	160	110	71	25	-	20	52	M16	M16 x 2.0P	4.20
5075-S50-025-120	HSK100A x SLNB25 - 120	170	120	86	24	22	25	65	M20	M18 x 2.0P	4.40
5075-S50-032-120	HSK100A x SLNB32 - 120	170	120	86	24	24	32	72	M20	M20 x 2.0P	4.50
5075-S50-040-120	HSK100A x SLNB40 - 120	170	120	89	30	32	40	90	M20	M20 x 2.0P	5.00
5076-S50-020-120	HSK125A x SLNB20 - 120	183	120	80	25	-	20	52	M16	M16 x 2.0P	4.80
5076-S50-025-130	HSK125A x SLNB25 - 130	193	130	90	24	22	25	65	M20	M18 x 2.0P	5.10
5076-S50-032-130	HSK125A x SLNB32 - 130	193	130	90	24	24	32	72	M20	M20 x 2.0P	5.50
5076-S50-040-140	HSK125A x SLNB40 - 140	203	140	100	30	32	40	90	M20	M20 x 2.0P	7.00



Product information:

- ▶ SLNB design: 2° screw hole taper enhances the holding power.
- ▶ Internal hole tolerance: H5.
- ▶ The tolerance requirement of tool shank diameter is h6.

Product information:

- ▶ The pre-balance reaches G6.3 8,000 rpm. Higher balancing grade and revolution can be done upon request but additional charge is needed.

Standard Accessory: • LOCK SCREW

Coolant Supply Unit	Key	Lock Screw
 P.X-70	 P.X-70	 P.X-113



HSK FACE MILL ARBOR

FMB TYPE

HSK 平面銑刀桿

[DIN 69893-1]

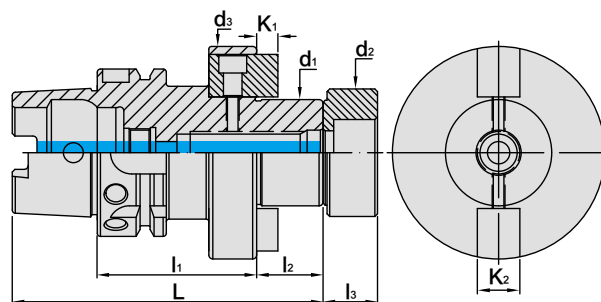
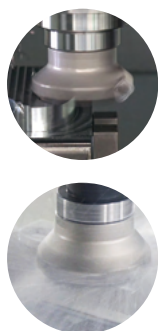

MODEL NO.	TYPE	L	l ₁	l ₂	l ₃	d ₁	d ₂	d ₃	K ₁	K ₂	WEIGHT (KGS)
5071-153-016-050	HSK40A x FMB16 - 50	87	50	17	-	16	-	40	5	8	0.70
5071-153-022-060	HSK40A x FMB22 - 60	99	60	19	14	22	26	52	5	10	0.80
5071-153-027-060	HSK40A x FMB27 - 60	100	60	20	16	27	31.5	60	6	12	1.00
5071-153-032-060	HSK40A x FMB32 - 60	102	60	22	16	32	41	78	7	14	1.10
5072-153-016-050	HSK50A x FMB16 - 50	92	50	17	-	16	-	40	5	8	1.10
5072-153-022-060	HSK50A x FMB22 - 60	104	60	19	14	22	26	48	5	10	1.00
5072-153-027-060	HSK50A x FMB27 - 60	105	60	20	16	27	31.5	60	6	12	1.30
5072-153-032-060	HSK50A x FMB32 - 60	107	60	22	16	32	41	78	6.8	14	1.50
5073-153-016-050	HSK63A x FMB16 - 50	99	50	17	-	16	-	40	5	8	1.20
5073-153-022-050	HSK63A x FMB22 - 50	101	50	19	14	22	26	50	5	10	1.30
5073-153-027-060	HSK63A x FMB27 - 60	112	60	20	16	27	31.5	53	6	12	1.50
5073-153-032-060	HSK63A x FMB32 - 60	114	60	22	16	32	41	78	6.8	14	1.60
5073-153-040-060	HSK63A x FMB40 - 60	117	60	25	20.5	40	48	80	8	16	2.10
5075-153-016-060	HSK100A x FMB16 - 60	127	60	17	-	16	-	40	5	8	2.31
5075-153-016-100	HSK100A x FMB16 - 100	167	100	17	-	16	-	40	5	8	2.66
5075-153-016-150	HSK100A x FMB16 - 150	217	150	17	-	16	-	40	5	8	3.10
5075-153-016-200	HSK100A x FMB16 - 200	267	200	17	-	16	-	40	5	8	3.58
5075-153-016-250	HSK100A x FMB16 - 250	317	250	17	-	16	-	40	5	8	4.02
5075-153-016-300	HSK100A x FMB16 - 300	367	300	17	-	16	-	40	5	8	4.46
5075-153-016-350	HSK100A x FMB16 - 350	417	350	17	-	16	-	40	5	8	4.90
5075-153-016-400	HSK100A x FMB16 - 400	467	400	17	-	16	-	40	5	8	5.34
5075-153-016-450	HSK100A x FMB16 - 450	517	450	17	-	16	-	40	5	8	5.78
5075-153-022-050	HSK100A x FMB22 - 50	119	50	19	14	22	26	48	5	10	2.70
5075-153-022-100	HSK100A x FMB22 - 100	169	100	19	14	22	26	48	5	10	3.04
5075-153-022-150	HSK100A x FMB22 - 150	219	150	19	14	22	26	48	5	10	3.69
5075-153-022-200	HSK100A x FMB22 - 200	269	200	19	14	22	26	48	5	10	4.34
5075-153-022-250	HSK100A x FMB22 - 250	319	250	19	14	22	26	48	5	10	5.00
5075-153-022-300	HSK100A x FMB22 - 300	369	300	19	14	22	26	48	5	10	5.65
5075-153-022-350	HSK100A x FMB22 - 350	419	350	19	14	22	26	48	5	10	6.34

Features:

- ▶ Tolerance of d1 the connection part with cutter: h6, which is good for less chatter and longer cutter life.
- ▶ Standard screw attached is w/o coolant hole.
- ▶ To use with face mill cutters with coolant holes, the standard screw has to be changed into the screw with coolant flute, which is available to order separately.

Product information:

- ▶ The pre-balance reaches G6.3 8,000 rpm. Higher balancing grade and revolution can be done upon request but additional charge is needed.

Coolant Supply Unit	Key	Screw
P.X-70	P.X-70	P.X-113



HSK FACE MILL ARBOR

FMB TYPE

HSK 平面銑刀桿

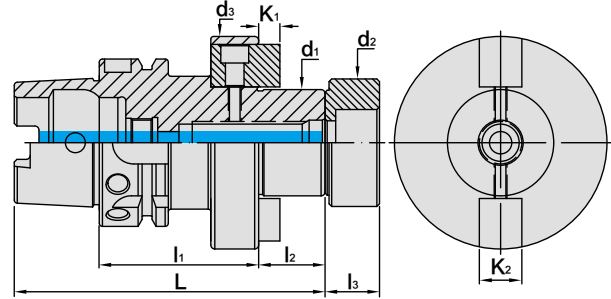

MODEL NO.	TYPE	L	l ₁	l ₂	l ₃	d ₁	d ₂	d ₃	K ₁	K ₂	WEIGHT (KGS)
5075-153-022-400	HSK100A x FMB22 - 400	469	400	19	14	22	26	48	5	10	6.99
5075-153-022-450	HSK100A x FMB22 - 450	519	450	19	14	22	26	48	5	10	7.65
5075-153-027-050	HSK100A x FMB27 - 50	120	50	20	16	27	31.5	60	5.8	12	2.90
5075-153-027-100	HSK100A x FMB27 - 100	170	100	20	16	27	31.5	60	6	12	3.67
5075-153-027-150	HSK100A x FMB27 - 150	220	150	20	16	27	31.5	60	6	12	4.73
5075-153-027-200	HSK100A x FMB27 - 200	270	200	20	16	27	31.5	60	6	12	5.79
5075-153-027-250	HSK100A x FMB27 - 250	320	250	20	16	27	31.5	60	6	12	6.84
5075-153-027-300	HSK100A x FMB27 - 300	370	300	20	16	27	31.5	60	6	12	7.90
5075-153-027-350	HSK100A x FMB27 - 350	420	350	20	16	27	31.5	60	6	12	8.96
5075-153-027-400	HSK100A x FMB27 - 400	470	400	20	16	27	31.5	60	6	12	10.01
5075-153-027-450	HSK100A x FMB27 - 450	520	450	20	16	27	31.5	60	6	12	11.07
5075-153-032-050	HSK100A x FMB32 - 50	122	50	22	16	32	41	78	7	14	3.00
5075-153-032-100	HSK100A x FMB32 - 100	172	100	22	16	32	41	78	7	14	4.81
5075-153-032-150	HSK100A x FMB32 - 150	222	150	22	16	32	41	78	7	14	6.62
5075-153-032-200	HSK100A x FMB32 - 200	272	200	22	16	32	41	78	7	14	8.43
5075-153-032-250	HSK100A x FMB32 - 250	322	250	22	16	32	41	78	7	14	10.23
5075-153-032-300	HSK100A x FMB32 - 300	372	300	22	16	32	41	78	7	14	12.04
5075-153-032-350	HSK100A x FMB32 - 350	422	350	22	16	32	41	78	7	14	13.85
5075-153-032-400	HSK100A x FMB32 - 400	472	400	22	16	32	41	78	7	14	15.66
5075-153-032-450	HSK100A x FMB32 - 450	522	450	22	16	32	41	78	7	14	17.41
5075-153-040-060	HSK100A x FMB40 - 60	135	60	25	20.5	40	48	80	8	16	4.00
5075-153-040-150	HSK100A x FMB40 - 150	225	150	25	20.5	40	48	80	8	16	7.08
5075-153-040-200	HSK100A x FMB40 - 200	275	200	25	20.5	40	48	80	8	16	8.97
5075-153-040-250	HSK100A x FMB40 - 250	325	250	25	20.5	40	48	80	8	16	10.86
5075-153-040-300	HSK100A x FMB40 - 300	375	300	25	20.5	40	48	80	8	16	12.75
5075-153-040-350	HSK100A x FMB40 - 350	425	350	25	20.5	40	48	80	8	16	14.64
5075-153-040-400	HSK100A x FMB40 - 400	475	400	25	20.5	40	48	80	8	16	16.53
5075-153-040-450	HSK100A x FMB40 - 450	525	450	25	20.5	40	48	80	8	16	18.43
5075-153-050-070	HSK100A x FMB50 - 70	150	70	30	24	50	65	120	10	19	5.10
5075-153-060-070	HSK100A x FMB60 - 70	160	70	40	-	60	-	129	12.4	25.4	5.50

Features:

- ▶ Tolerance of d1 the connection part with cutter: h6, which is good for less chatter and longer cutter life.
- ▶ Standard screw attached is w/o coolant hole.
- ▶ To use with face mill cutters with coolant holes, the standard screw has to be changed into the screw with coolant flute, which is available to order separately.

Product information:

- ▶ The pre-balance reaches G6.3 8,000 rpm. Higher balancing grade and revolution can be done upon request but additional charge is needed.

Coolant Supply Unit	Key	Screw
P.X-70	P.X-70	P.X-113



HSK FACE MILL ARBOR

FMB TYPE

HSK 平面銑刀桿

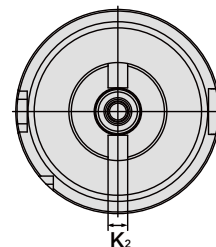
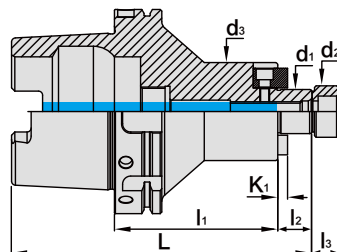
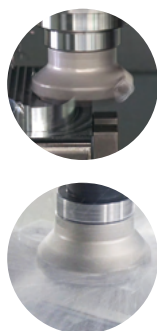



MODEL NO.	TYPE	L	l ₁	l ₂	l ₃	d ₁	d ₂	d ₃	K ₁	K ₂	WEIGHT (KGS)
5076-153-022-050	HSK125A x FMB22 - 50	132	50	19	14	22	26	48	4.8	10	3.80
5076-153-022-100	HSK125A x FMB22 - 100	182	100	19	14	22	26	48	5	10	5.00
5076-153-022-130	HSK125A x FMB22 - 130	212	130	19	14	22	26	48	5	10	5.30
5076-153-022-160	HSK125A x FMB22 - 160	242	160	19	14	22	26	48	5	10	6.40
5076-153-022-200	HSK125A x FMB22 - 200	282	200	19	14	22	26	48	5	10	7.80
5076-153-027-055	HSK125A x FMB27 - 55	138	55	20	16	27	31.5	60	6	12	4.20
5076-153-027-100	HSK125A x FMB27 - 100	183	100	20	16	27	31.5	60	6	12	5.50
5076-153-027-130	HSK125A x FMB27 - 130	213	130	20	16	27	31.5	60	6	12	6.10
5076-153-027-160	HSK125A x FMB27 - 160	243	160	20	16	27	31.5	60	6	12	7.30
5076-153-027-200	HSK125A x FMB27 - 200	283	200	20	16	27	31.5	60	6	12	8.80
5076-153-032-070	HSK125A x FMB32 - 70	155	70	22	16	32	41	78	7	14	5.40
5076-153-032-100	HSK125A x FMB32 - 100	185	100	22	16	32	41	78	7	14	6.50
5076-153-032-130	HSK125A x FMB32 - 130	215	130	22	16	32	41	78	7	14	7.50
5076-153-032-160	HSK125A x FMB32 - 160	245	160	22	16	32	41	78	7	14	8.90
5076-153-032-200	HSK125A x FMB32 - 200	285	200	22	16	32	41	78	7	14	10.80
5076-153-040-060	HSK125A x FMB40 - 60	148	60	25	20.5	40	48	80	8	16	5.10
5076-153-040-100	HSK125A x FMB40 - 100	188	100	25	20.5	40	48	80	8	16	6.80
5076-153-040-130	HSK125A x FMB40 - 130	218	130	25	20.5	40	48	80	8	16	7.90
5076-153-040-160	HSK125A x FMB40 - 160	248	160	25	20.5	40	48	80	8	16	9.30
5076-153-040-200	HSK125A x FMB40 - 200	288	200	25	20.5	40	48	80	8	16	11.30
5076-153-050-070	HSK125A x FMB50 - 70	163	70	30	24	50	65	120	10	19	7.40

Features:

- ▶ Tolerance of d1 the connection part with cutter: h6, which is good for less chatter and longer cutter life.
- ▶ Standard screw attached is w/o coolant hole.
- ▶ To use with face mill cutters with coolant holes, the standard screw has to be changed into the screw with coolant flute, which is available to order separately.

Product information:

- ▶ The pre-balance reaches G6.3 8,000 rpm. Higher balancing grade and revolution can be done upon request but additional charge is needed.

Coolant Supply Unit	Key	Screw
 P.X-70	 P.X-70	 P.X-113



HSK FACE MILL ARBOR

FMC TYPE

HSK 平面銑刀桿

[DIN 69893-1]

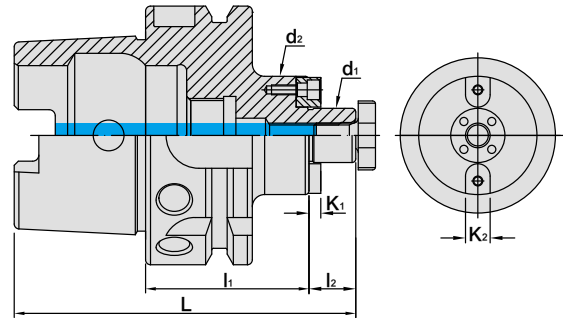

MODEL NO.	TYPE	L	l ₁	l ₂	d ₁	d ₂	K ₁	K ₂	WEIGHT (KGS)
5072-157-016-060	HSK50A x FMC16 - 60	102	60	17	16	40	5	8	1.30
5072-157-022-060	HSK50A x FMC22 - 60	104	60	19	22	50	4.8	10	1.40
5072-157-027-060	HSK50A x FMC27 - 60	105	60	20	27	60	5.8	12	1.30
5073-157-016-050	HSK63A x FMC16 - 50	99	50	17	16	40	5	8	1.20
5073-157-022-050	HSK63A x FMC22 - 50	101	50	19	22	50	4.8	10	1.30
5073-157-027-060	HSK63A x FMC27 - 60	112	60	20	27	58	5.8	12	1.70
5073-157-032-060	HSK63A x FMC32 - 60	114	60	22	32	78	6.8	14	1.60
5075-157-016-050	HSK100A x FMC16 - 50	117	50	17	16	40	5	8	2.80
5075-157-022-050	HSK100A x FMC22 - 50	119	50	19	22	50	4.8	10	2.90
5075-157-027-050	HSK100A x FMC27 - 50	120	50	20	27	60	5.8	12	2.90
5075-157-032-060	HSK100A x FMC32 - 60	132	60	22	32	78	6.8	14	3.30
5075-157-040-070	HSK100A x FMC40 - 70	145	70	25	40	89	7.9	16	4.30
5076-157-022-050	HSK125A x FMC22 - 50	132	50	19	22	50	4.8	10	3.90
5076-157-027-055	HSK125A x FMC27 - 55	138	55	20	27	60	5.8	12	4.10
5076-157-027-100	HSK125A x FMC27 - 100	183	100	20	27	60	5.8	12	5.90
5076-157-032-070	HSK125A x FMC32 - 70	155	70	22	32	78	6.8	14	5.20
5076-157-032-100	HSK125A x FMC32 - 100	185	100	22	32	78	6.8	14	6.60
5076-157-040-060	HSK125A x FMC40 - 60	148	60	25	40	89	7.9	16	5.00
5076-157-040-100	HSK125A x FMC40 - 100	188	100	25	40	89	7.9	16	7.00







Features:

- ▶ With four coolant holes on the face of tool holder to match with face mill cutters with coolant holes.
- ▶ Tolerance of d1 the connection part with cutter: h6, which is good for less chatter and longer cutter life

Product information:

- ▶ d1 tolerance: h6.
- ▶ The pre-balance reaches G6.3 8,000 rpm. Higher balancing grade and revolution can be done upon request but additional charge is needed.

Standard Accessory: • NUT • SPANNER

Coolant Supply Unit	Key	Nut	Spanner
			
P.X-70	P.X-70	P.X-72	P.X-72

HSK / STA SYNCHRONIZED TAPPING HOLDER



HSK / STA 同步補償攻牙刀桿

[ER TYPE]

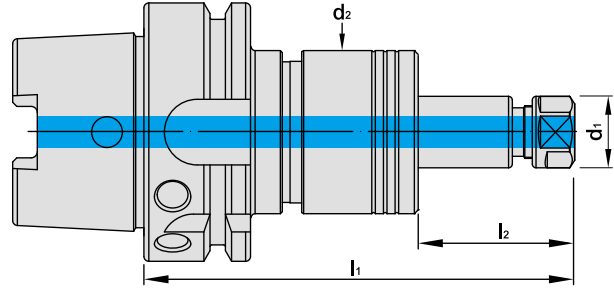

TW PAT NO. I615223
 CN PAT NO. ZL201620889099.X
 J P PAT NO. 3203456
 D E PAT NO. Nr.202016100106
 U S PAT NO. US9796059

MODEL NO.	TYPE	l ₁	l ₂	d ₁	d ₂	COMBINATION		WEIGHT (KGS)
						BODY	TAP ADAPTER	
5071-S22-011-140	HSK40A x STA11E - 140	140	70	19	42	HSK40A x STA1	STA1 - ER11A - 70	1.46
5071-S22-016-095	HSK40A x STA16E - 95	95	25	28	42	HSK40A x STA1	STA1 - ER16A - 25	1.20
5071-S22-016-140	HSK40A x STA16E - 140	140	70	28	42	HSK40A x STA1	STA1 - ER16A - 70	1.40
5071-S22-016-220	HSK40A x STA16E - 220	220	150	28	42	HSK40A x STA1	STA1 - ER16A - 150	1.73
5071-S22-020-104	HSK40A x STA20E - 104	104	34	34	42	HSK40A x STA1	STA1 - ER20A - 34	1.24
5071-S22-020-140	HSK40A x STA20E - 140	140	70	34	42	HSK40A x STA1	STA1 - ER20A - 70	1.40
5072-S22-011-140	HSK50A x STA11E - 140	140	70	19	42	HSK50A x STA1	STA1 - ER11A - 70	1.67
5072-S22-016-095	HSK50A x STA16E - 95	95	25	28	42	HSK50A x STA1	STA1 - ER16A - 25	1.41
5072-S22-016-140	HSK50A x STA16E - 140	140	70	28	42	HSK50A x STA1	STA1 - ER16A - 70	1.61
5072-S22-016-220	HSK50A x STA16E - 220	220	150	28	42	HSK50A x STA1	STA1 - ER16A - 150	1.94
5072-S22-020-104	HSK50A x STA20E - 104	104	34	34	42	HSK50A x STA1	STA1 - ER20A - 34	1.45
5072-S22-020-140	HSK50A x STA20E - 140	140	70	34	42	HSK50A x STA1	STA1 - ER20A - 70	1.61
5073-S22-011-150	HSK63A x STA11E - 150	150	70	19	42	HSK63A x STA1	STA1 - ER11A - 70	1.96
5073-S22-016-105	HSK63A x STA16E - 105	105	25	28	42	HSK63A x STA1	STA1 - ER16A - 25	1.70
5073-S22-016-150	HSK63A x STA16E - 150	150	70	28	42	HSK63A x STA1	STA1 - ER16A - 70	1.90
5073-S22-016-230	HSK63A x STA16E - 230	230	150	28	42	HSK63A x STA1	STA1 - ER16A - 150	2.23
5073-S22-020-114	HSK63A x STA20E - 114	114	34	34	42	HSK63A x STA1	STA1 - ER20A - 34	1.74
5073-S22-020-150	HSK63A x STA20E - 150	150	70	34	42	HSK63A x STA1	STA1 - ER20A - 70	1.90
5074-S22-011-150	HSK80A x STA11E - 150	150	70	19	42	HSK80A x STA1	STA1 - ER11A - 70	2.34
5074-S22-016-105	HSK80A x STA16E - 105	105	25	28	42	HSK80A x STA1	STA1 - ER16A - 25	2.08
5074-S22-016-150	HSK80A x STA16E - 150	150	70	28	42	HSK80A x STA1	STA1 - ER16A - 70	2.28
5074-S22-016-230	HSK80A x STA16E - 230	230	150	28	42	HSK80A x STA1	STA1 - ER16A - 150	2.61
5074-S22-020-114	HSK80A x STA20E - 114	114	34	34	42	HSK80A x STA1	STA1 - ER20A - 34	2.12
5074-S22-020-150	HSK80A x STA20E - 150	150	70	34	42	HSK80A x STA1	STA1 - ER20A - 70	2.28
5074-S22-032-135	HSK80A x STA32E - 135	135	40	50	58	HSK80A x STA2	STA2 - ER32 - 40	3.24
5074-S22-032-165	HSK80A x STA32E - 165	165	70	50	58	HSK80A x STA2	STA2 - ER32 - 70	3.47
5075-S22-011-150	HSK100A x STA11E - 150	150	70	19	42	HSK100A x STA1	STA1 - ER11A - 70	3.14
5075-S22-016-105	HSK100A x STA16E - 105	105	25	28	42	HSK100A x STA1	STA1 - ER16A - 25	2.88
5075-S22-016-150	HSK100A x STA16E - 150	150	70	28	42	HSK100A x STA1	STA1 - ER16A - 70	3.08
5075-S22-016-230	HSK100A x STA16E - 230	230	150	28	42	HSK100A x STA1	STA1 - ER16A - 150	3.41
5075-S22-020-114	HSK100A x STA20E - 114	114	34	34	42	HSK100A x STA1	STA1 - ER20A - 34	2.92
5075-S22-020-150	HSK100A x STA20E - 150	150	70	34	42	HSK100A x STA1	STA1 - ER20A - 70	3.08
5075-S22-032-135	HSK100A x STA32E - 135	135	40	50	58	HSK100A x STA2	STA2 - ER32 - 40	4.04
5075-S22-032-165	HSK100A x STA32E - 165	165	70	50	58	HSK100A x STA2	STA2 - ER32 - 70	4.27

Standard Accessory: • NUT

Collet	Nut	Coolant Supply Unit	Key	Spanner	STA Flange
P.X18~37	P.X-54~58	P.X-70	P.X-70	PX-73~74、79	P.X-101



STA SYNCHRONIZED TAPPING HOLDER BODY

STA 同步補償攻牙刀桿本體

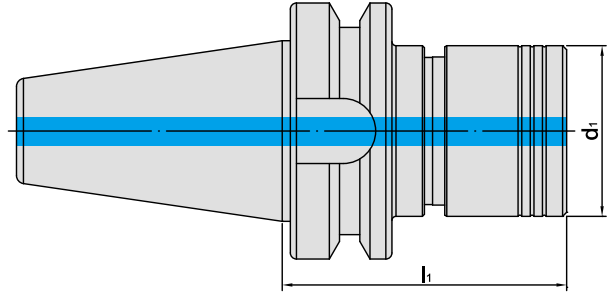

TW PAT NO. I615223
 CN PAT NO. ZL201620889099.X
 J P PAT NO. 3203456
 D E PAT NO. Nr.202016100106
 U S PAT NO. US9796059

MODEL NO.	TYPE	l_1	d_1	STA NO.	WEIGHT (KGS)
5071-795-001-070	HSK40A x STA1 - 70	70	42	1	1.10
5072-795-001-070	HSK50A x STA1 - 70	70	42	1	1.31
5073-795-001-080	HSK63A x STA1 - 80	80	42	1	1.60
5074-795-001-080	HSK80A x STA1 - 80	80	42	1	1.98
5074-795-002-095	HSK80A x STA2 - 95	95	58	2	2.80
5075-795-001-080	HSK100A x STA1 - 80	80	42	1	2.78
5075-795-002-095	HSK100A x STA2 - 95	95	58	2	3.60



HSK / QTC QUICK CHANGE TAPPING CHUCK

With length compensation on tension and compression

HSK / QTC 快換式扭力攻牙刀桿 [伸縮緩衝型]

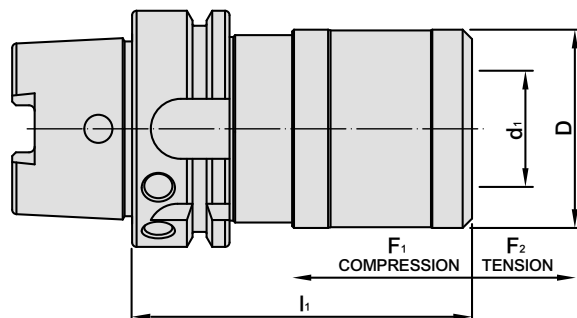

MODEL NO.	TYPE	TAPPING COLLET	TAPPING CAPACITY	COMPENSATION		l ₁	D	d ₁	WEIGHT (KGS)
				F ₁	F ₂				
5071-580-001-095	HSK40A x QTC1 - 95	TCS - 1B	M3 - M14	7.5	7.5	95	36	19	0.72
5072-580-001-100	HSK50A x QTC1 - 100	TCS - 1B	M3 - M14	7.5	7.5	100	36	19	0.97
5072-580-002-140	HSK50A x QTC2 - 140	TCS - 2B	M8 - M24	12.5	12.5	140	53	31	1.89
5073-580-001-090	HSK63A x QTC1 - 90	TCS - 1B	M3 - M14	7.5	7.5	90	36	19	1.15
5073-580-002-125	HSK63A x QTC2 - 125	TCS - 2B	M8 - M24	12.5	12.5	125	53	31	1.89
5073-580-003-175	HSK63A x QTC3 - 175	TCS - 3B	M14 - M36	20	20	175	78	48	3.61
5075-580-001-100	HSK100A x QTC1 - 100	TCS - 1B	M3 - M14	7.5	7.5	100	36	19	2.58
5075-580-002-135	HSK100A x QTC2 - 135	TCS - 2B	M8 - M24	12.5	12.5	135	53	31	3.51
5075-580-003-185	HSK100A x QTC3 - 185	TCS - 3B	M14 - M36	20	20	185	78	48	5.46

Features:

- ▶ Quick and easy tool change in seconds!
- ▶ Absorb any inaccuracies between the rotating spindle and the moving Z-axis, increasing tap life and the improving tapping quality.
- ▶ Most commonly used for old CNC machines without rigid tapping. The length compensation prevents oversized threads and helps prevent tap breakage from excessive torque or over travel when the tap hits the bottom of the hole.

Synchronized Tapping Holder:

- ▶ Ideal for everyday tapping, high speed and high production tapping for modern CNC machines capable of rigid tapping.
- ▶ Also ideal for high-end tapping applications in modern CNC machines, such as: small taps or difficult materials resulting in high torque loads.

Tapping Collet	Coolant Supply Unit	Key
 P.A-56~59	 P.X-70	 P.X-70



HSK / COMBI SHELL END MILL ARBOR

HSK 聯結式銑刀桿

(DIN 69228-2)

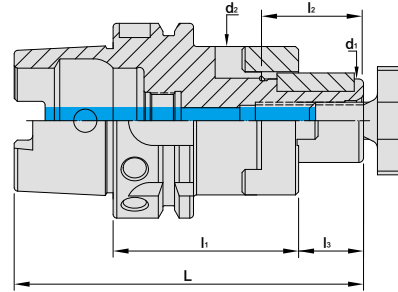

MODEL NO.	TYPE	L	l ₁	l ₂	l ₃	d ₁	d ₂	WEIGHT (KGS)
5070-061-016-055	HSK32A x CSR16 - 55	88	55	27	17	16	32	0.50
5070-061-022-055	HSK32A x CSR22 - 55	90	55	31	19	22	40	0.50
5070-061-027-065	HSK32A x CSR27 - 65	102	65	33	21	27	48	0.60
5071-061-016-050	HSK40A x CSR16 - 50	87	50	27	17	16	32	0.50
5071-061-022-050	HSK40A x CSR22 - 50	89	50	31	19	22	40	0.60
5071-061-027-065	HSK40A x CSR27 - 65	106	65	33	21	27	48	0.70
5072-061-016-050	HSK50A x CSR16 - 50	92	50	27	17	16	32	0.77
5072-061-022-050	HSK50A x CSR22 - 50	94	50	31	19	22	40	0.88
5072-061-027-065	HSK50A x CSR27 - 65	111	65	33	21	27	48	1.10
5072-061-032-065	HSK50A x CSR32 - 65	114	65	38	24	32	50	1.40
5073-061-016-060	HSK63A x CSR16 - 60	109	60	27	17	16	32	0.97
5073-061-022-060	HSK63A x CSR22 - 60	111	60	31	19	22	40	1.08
5073-061-027-060	HSK63A x CSR27 - 60	113	60	33	21	27	48	1.30
5073-061-032-060	HSK63A x CSR32 - 60	116	60	38	24	32	52	1.60
5073-061-040-070	HSK63A x CSR40 - 70	129	70	41	27	40	70	2.05
5075-061-016-060	HSK100A x CSR16 - 60	127	60	27	17	16	32	2.47
5075-061-022-060	HSK100A x CSR22 - 60	129	60	31	19	22	40	2.68
5075-061-027-060	HSK100A x CSR27 - 60	131	60	33	21	27	48	2.90
5075-061-032-060	HSK100A x CSR32 - 60	134	60	38	24	32	58	3.20
5075-061-040-070	HSK100A x CSR40 - 70	147	70	41	27	40	70	3.65
5075-061-050-080	HSK100A x CSR50 - 80	160	80	46	30	50	90	4.10

Features:

- ▶ Used with face milling cutters or side disc cutters.
- ▶ Removable ring, nut and spanner are included.

Product information:

- ▶ d1 tolerance: h6.
- ▶ The pre-balance reaches G6.3 8,000 rpm. Higher balancing grade and revolution can be done upon request but additional charge is needed.

Standard Accessory: • Key • REMOVABLE RING • NUT • SPANNER

Coolant Supply Unit	Key	Key	Removable Ring	Nut	Spanner
P.X-70	P.X-70	P.X-72	P.X-72	P.X-72	P.X-72

HSK / SPH DRILL CHUCK ADAPTER

HSK / SPH 直結式鑽夾頭

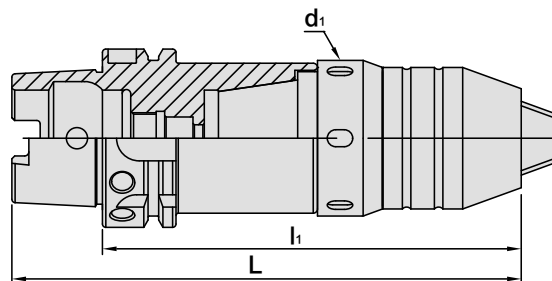

MODEL NO.	TYPE	L	l ₁	d ₁	CAPACITY	WEIGHT (KGS)
5071-680-008-135	HSK40A x SPH8 - 135	155	135	42	1 ~ 8	1.40
5071-680-013-150	HSK40A x SPH13 - 150	170	150	54	1 ~ 13	1.60
5073-680-008-130	HSK63A x SPH8 - 130	162	130	42	1 ~ 8	1.40
5073-680-013-150	HSK63A x SPH13 - 150	182	150	54	1 ~ 13	1.60



Features:

- ▶ The adapter has a taper design to assemble with drill chuck and then lock with a screw, ensuring to have better stability and drill chuck would not fall off.
- ▶ Used for drilling & tapping.

Product information:

- ▶ The pre-balance reaches G6.3 8,000 rpm. Higher balancing grade and revolution can be done upon request but additional charge is needed.

Standard Accessory: • SPANNER

Coolant Supply Unit	Key
 P.X-70	 P.X-70



HSK / SPU DRILL CHUCK ADAPTER

HSK / SPU 直結式鑽夾頭

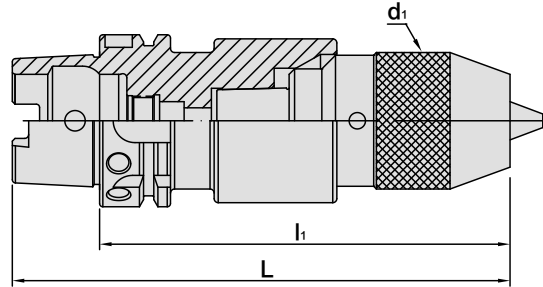

MODEL NO.	TYPE	L	l ₁	d ₁	CAPACITY	WEIGHT (KGS)
5072-669-013-150	HSK50A x SPU13 - 150	175	150	50	1 ~ 13	1.40
5073-669-013-150	HSK63A x SPU13 - 150	182	150	50	1 ~ 13	2.10
5075-669-013-155	HSK100A x SPU13 - 155	205	155	50	1 ~ 13	3.10



Features:

- ▶ The adapter has a taper design to assemble with drill chuck and then lock with a screw, ensuring to have better stability and drill chuck would not fall off.
- ▶ Used for drilling.

Product information:

- ▶ The pre-balance reaches G6.3 8,000 rpm. Higher balancing grade and revolution can be done upon request but additional charge is needed.

Standard Accessory: • SPANNER

Coolant Supply Unit	Key	Spanner
		
P.X-70	P.X-70	P.X-80



HSK / SOM SCREWED END MILL HOLDER

HSK / SOM 螺紋鎖固式刀桿

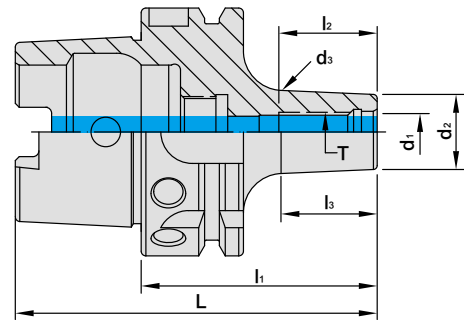

MODEL NO.	TYPE	L	l ₁	l ₂	l ₃	d ₁	d ₂	d ₃	T	WEIGHT (KGS)
5072-670-006-060	HSK50A x SOM6 - 60	85	60	25	24	6.5	13	15	M6 x 1.0P	0.70
5072-670-008-060	HSK50A x SOM8 - 60	85	60	25	24	8.5	15	17	M8 x 1.25P	0.70
5072-670-010-060	HSK50A x SOM10 - 60	85	60	25	24	10.5	19	21	M10 x 1.5P	0.80
5072-670-012-070	HSK50A x SOM12 - 70	95	70	31	36	12.5	21	24	M12 x 1.75P	0.80
5072-670-016-080	HSK50A x SOM16 - 80	105	80	31	49	17	25	29	M16 x 2.0P	0.80
5073-670-006-060	HSK63A x SOM6 - 60	92	60	25	24	6.5	13	15	M6 x 1.0P	1.00
5073-670-008-060	HSK63A x SOM8 - 60	92	60	25	24	8.5	15	17	M8 x 1.25P	1.00
5073-670-010-060	HSK63A x SOM10 - 60	92	60	25	24	10.5	19	21	M10 x 1.5P	1.10
5073-670-012-070	HSK63A x SOM12 - 70	102	70	31	34	12.5	21	23	M12 x 1.75P	1.10
5073-670-016-080	HSK63A x SOM16 - 80	112	80	30	49	17	25	29	M16 x 2.0P	1.10
5075-670-006-090	HSK100A x SOM6 - 90	140	90	25	51	6.5	13	17	M6 x 1.0P	2.18
5075-670-008-090	HSK100A x SOM8 - 90	140	90	25	51	8.5	15	19	M8 x 1.25P	2.19
5075-670-010-095	HSK100A x SOM10 - 95	145	95	25	56	10.5	19	23	M10 x 1.5P	2.26
5075-670-012-090	HSK100A x SOM12 - 90	140	90	31	51	12.5	21	25	M12 x 1.75P	2.31
5075-670-016-100	HSK100A x SOM16 - 100	150	100	31	61	17	25	30	M16 x 2.0P	2.55

Features:

- Used with STR, RG, and DM Screwed cutting tools



HSK MORSE TAPER ADAPTER

TANG TYPE

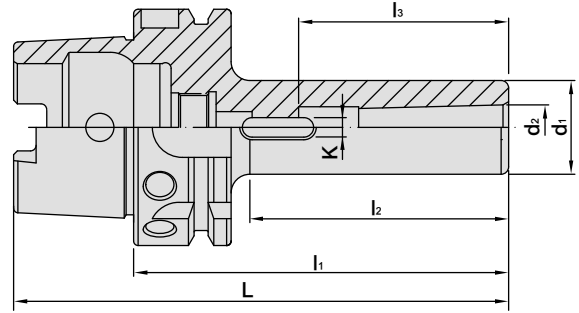

HSK 斜柄鑽頭套筒



MODEL NO.	TYPE	L	l ₁	l ₂	l ₃	d ₁	d ₂	K	WEIGHT (KGS)
5072-465-001-100	HSK50A x MTA1 - 100	125	100	69	56	25	12.065	5.2	1.50
5072-465-002-120	HSK50A x MTA2 - 120	145	120	89	67	32	17.78	6.3	1.80
5072-465-003-140	HSK50A x MTA3 - 140	165	140	113	84	40	23.825	7.9	1.90
5073-465-001-100	HSK63A x MTA1 - 100	132	100	69	56	25	12.065	5.2	1.90
5073-465-002-120	HSK63A x MTA2 - 120	152	120	89	67	32	17.78	6.3	2.00
5073-465-003-140	HSK63A x MTA3 - 140	172	140	109	84	40	23.825	7.9	2.20
5073-465-004-160	HSK63A x MTA4 - 160	192	160	132	107	48	31.267	11.9	2.50
5075-465-001-110	HSK100A x MTA1 - 110	160	110	71	56	25	12.065	5.2	3.40
5075-465-002-120	HSK100A x MTA2 - 120	170	120	81	67	32	17.78	6.3	3.80
5075-465-003-150	HSK100A x MTA3 - 150	200	150	111	84	40	23.825	7.9	4.00
5075-465-004-170	HSK100A x MTA4 - 170	220	170	131	107	48	31.267	11.9	4.60
5075-465-005-200	HSK100A x MTA5 - 200	250	200	166	135	63	44.399	15.9	5.20

Features:

► Convert the machine taper for use with different taper types or taper sizes of tool holders, or offer great flexibility by extending the tooling length.

Coolant Supply Unit	Key
 P.X-70	 P.X-70

HSK / PSC ADAPTER

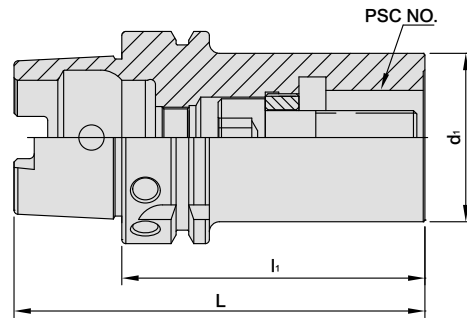

HSK / PSC 套筒



MODEL NO.	TYPE	NO.	L	l ₁	d ₁	T	MAX. TORQUE		WEIGHT (KGS)
							Nm	ft-lbs	
5073-013-140-075	HSK63A x PSC32 - 75	PSC32	107	75	32	M12 x 1.5P	45	33	0.92
5073-013-141-080	HSK63A x PSC40 - 80	PSC40	112	80	40	M14 x 1.5P	55	40	1.06
5073-013-142-090	HSK63A x PSC50 - 90	PSC50	122	90	50	M16 x 1.5P	95	70	1.39
5075-013-140-080	HSK100A x PSC32 - 80	PSC32	130	80	32	M12 x 1.5P	45	33	2.25
5075-013-141-090	HSK100A x PSC40 - 90	PSC40	140	90	40	M14 x 1.5P	55	40	2.43
5075-013-142-100	HSK100A x PSC50 - 100	PSC50	150	100	50	M16 x 1.5P	95	70	2.80
5075-013-143-110	HSK100A x PSC63 - 110	PSC63	160	110	63	M20 x 2.0P	170	125	3.41
5075-013-143-150	HSK100A x PSC63 - 150	PSC63	200	150	63	M20 x 2.0P	170	125	4.18
5075-013-143-200	HSK100A x PSC63 - 200	PSC63	250	200	63	M20 x 2.0P	170	125	5.14
5075-013-143-250	HSK100A x PSC63 - 250	PSC63	300	250	63	M20 x 2.0P	170	125	6.10
5075-013-143-300	HSK100A x PSC63 - 300	PSC63	350	300	63	M20 x 2.0P	170	125	7.07
5075-013-144-120	HSK100A x PSC80 - 120	PSC80	170	120	80	M20 x 2.0P	170	125	4.93
5075-013-146-155	HSK100A x PSC100 - 155	PSC100	205	155	100	M24 x 2.0P	380	277	7.29

Features:

- Convert the machine taper for use with different taper types or taper sizes of tool holders, or offer great flexibility by extending the tooling length.

Coolant Supply Unit	Key
 P.X-70	 P.X-70



HSK BLANK

HSK 素材

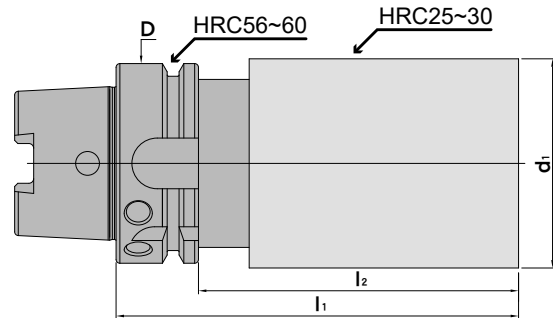

MODEL NO.	TYPE	D	d ₁	l ₁	l ₂	WEIGHT (KGS)
5070-001-033-100	HSK32A x Ø32.5 - 100	32	32.5	100	80	0.59
5070-001-050-120	HSK32A x Ø50 - 120	32	50	120	100	1.48
5070-001-067-044	HSK32A x Ø67 - 43.8	32	67	43.8	23.8	0.51
5071-001-041-160	HSK40A x Ø40.5 - 160	40	40.5	160	140	1.56
5072-001-051-200	HSK50A x Ø50.5 - 200	50	50.5	200	174	3.04
5073-001-062-076	HSK63A x Ø62 - 3"	63	62	76.2	50.2	1.80
5073-001-062-102	HSK63A x Ø62 - 4"	63	62	101.6	75.6	2.39
5073-001-062-127	HSK63A x Ø62 - 5"	63	62	127	101	2.98
5073-001-064-240	HSK63A x Ø64 - 240	63	64	240	214	5.91
5073-001-080-065	HSK63A x Ø80 - 65	63	80	65	39	1.81
5073-001-080-150	HSK63A x Ø80 - 150	63	80	150	124	5.16
5073-001-080-250	HSK63A x Ø80 - 250	63	80	250	224	9.11
5073-001-100-192	HSK63A x Ø100 - 192	63	100	192	166	10.15
5075-001-075-200	HSK100A x Ø75 - 200	100	75	200	171	7.87
5075-001-097-250	HSK100A x Ø97 - 250	100	97	250	221	14.47
5085-001-032-100	HSK32C x Ø32 - 100	32	32	100	-	0.79
5088-001-115-150	HSK63C x Ø115 - 150	63	115	150	137.5	11.48
INCHES						
5073-001-B02-600	HSK63A x Ø2.5" - 6"	63	2.5	6	4.98	3.69
5075-001-A80-200	HSK100A x Ø1.5" - 2"	100	1.5	2	0.86	2.25
5075-001-A80-812	HSK100A x Ø1.5" - 8.12"	100	1.5	8.12	6.98	3.61
5075-001-A80-1100	HSK100A x Ø1.5" - 11"	100	1.5	11	9.86	4.25
5075-001-B16-1000	HSK100A x Ø4" - 10"	100	4	10	8.86	15.85

Features:

- Blanks can be machined according to customer demands. It is not recommended to do heat treatment after machining.



REFERENCE DETAILS

DIN 69893 - 5

- ▶ Shank body standard: **DIN 69893 - 5**
- ▶ Taper tolerance < **AT3**
- ▶ Hardness > **HRC 56°**
- ▶ Surface roughness: Ra < **0.25 μm**
- ▶ Roundness < **0.8 μm**
- ▶ Carbon depth > **0.8mm**
- ▶ The shank has pre-balance at G6.3, and can provide precision balance at G2.5. It can be ordered by request.

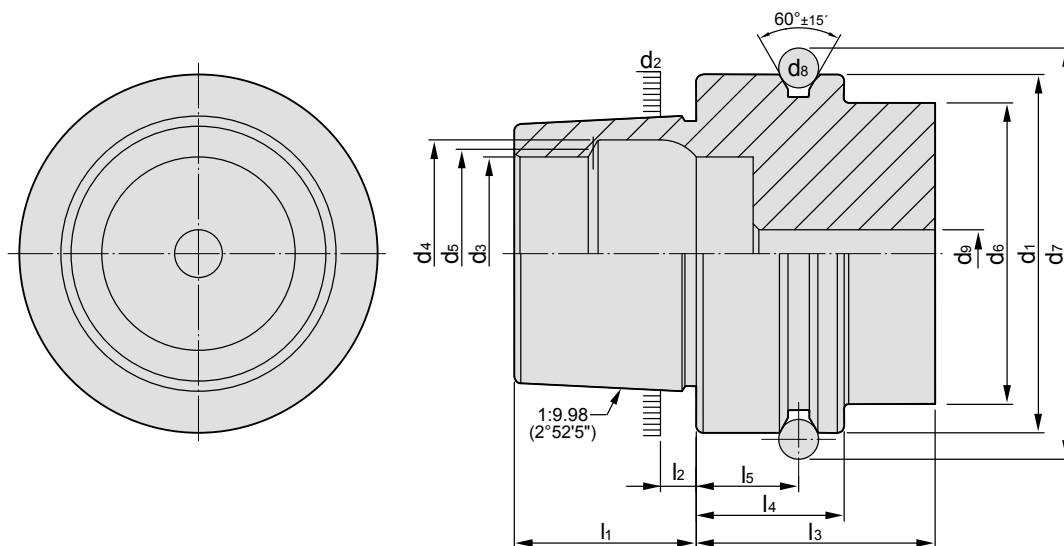

FROM E

HSK	d ₁ h ₁₀	d ₂	d ₃ H ₁₀	d ₄ H ₁₁	d ₅	d ₆ max.	d ₇ 0 -0.1
25	25	19.006	14	16.4	15	20	28.5
32	32	24.007	17	20.5	19	26	37
40	40	30.007	21	25.5	23	34	45
50	50	38.009	26	32	29	42	59.3
63	63	48.010	34	40	37	53	72.3
80	80	60.012	42	50	46	68	88.8
100	100	75.013	53	63	58	88	109.75
125	125	95.016	67	80	73	111	134.75
HSK	d ₈	d ₉ max.	l ₁ 0 -0.2	l ₂	l ₃ min.	l ₄ 0 -0.1	l ₅ ±0.1
25	3	3	13	2.5	20	10	4.5
32	4	4.2	16	3.2	35	20	16
40	4	5	20	4	35	20	16
50	7	6.8	25	5	42	26	18
63	7	8.4	32	6.3	42	26	18
80	7	10.2	40	8	42	26	18
100	7	12	50	10	45	29	20
125	7	14	63	12.5	45	29	20



HSK / PRO-E COLLET CHUCK



HSK / PRO-E 筒夾式刀桿

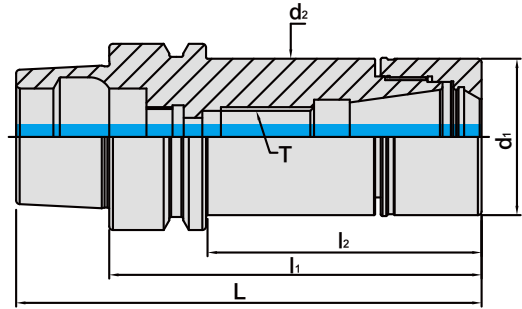

MODEL NO.	TYPE	L	l ₁	l ₂	d ₁	d ₂	T	SIZE RANGE	WEIGHT (KGS)
5097-529-016-060	HSK25E x PRO-E16 - 60	73	60	49	30	30	-	1 ~ 10	0.22
5098-529-016-065	HSK32E x PRO-E16 - 65	81	65	44	30	30	-	1 ~ 10	0.29
5099-529-016-060	HSK40E x PRO-E16 - 60	80	60	39	30	30	-	1 ~ 10	0.37
5099-529-020-070	HSK40E x PRO-E20 - 70	90	70	49	35	34	-	1 ~ 13	0.50
5099-529-020-100	HSK40E x PRO-E20 - 100	120	100	79	35	34	M12 x 1.75P	1 ~ 13	0.68
5099-529-020-125	HSK40E x PRO-E20 - 125	145	125	104	35	34	M12 x 1.75P	1 ~ 13	0.85
5099-529-025-070	HSK40E x PRO-E25 - 70	90	70	49.5	42	42	-	1 ~ 16	0.53
5099-529-025-100	HSK40E x PRO-E25 - 100	120	100	79.5	42	42	M16 x 2.0P	1 ~ 16	0.82
5099-529-025-125	HSK40E x PRO-E25 - 125	145	125	104.5	42	42	M16 x 2.0P	1 ~ 16	1.08
5099-529-025-150	HSK40E x PRO-E25 - 150	170	150	129.5	42	42	M16 x 2.0P	1 ~ 16	1.34
5099-529-032-070	HSK40E x PRO-E32 - 70	90	70	49.5	50	50	-	2 ~ 20	0.57
5099-529-032-100	HSK40E x PRO-E32 - 100	120	100	79.5	50	50	M16 x 2.0P	2 ~ 20	1.00
5100-584-011-055	HSK50E x PRO-E11M - 55	80	55	26	16	16	-	2 ~ 7	0.44
5100-584-011-080	HSK50E x PRO-E11M - 80	105	80	44	16	16	M6 x 1.0P	2 ~ 7	0.48
5100-529-016-070	HSK50E x PRO-E16 - 70	95	70	41	30	30	-	1 ~ 10	0.60
5100-529-016-100	HSK50E x PRO-E16 - 100	125	100	71	30	30	M10 x 1.5P	1 ~ 10	0.75
5100-529-020-070	HSK50E x PRO-E20 - 70	95	70	41	35	35	-	1 ~ 13	0.66
5100-529-020-100	HSK50E x PRO-E20 - 100	125	100	71	35	35	M12 x 1.75P	1 ~ 13	0.86
5100-529-020-125	HSK50E x PRO-E20 - 125	150	125	96	35	35	M12 x 1.75P	1 ~ 13	1.04
5100-529-020-150	HSK50E x PRO-E20 - 150	175	150	121	35	35	M12 x 1.75P	1 ~ 13	1.22
5100-529-025-070	HSK50E x PRO-E25 - 70	95	70	43.5	42	42	-	1 ~ 16	0.70
5100-529-025-100	HSK50E x PRO-E25 - 100	125	100	73.5	42	42	M16 x 2.0P	1 ~ 16	0.99
5100-529-032-070	HSK50E x PRO-E32 - 70	95	70	43.5	50	42	-	2 ~ 20	0.76
5100-529-032-100	HSK50E x PRO-E32 - 100	125	100	73	50	50	M16 x 2.0P	2 ~ 20	1.13
5100-529-032-125	HSK50E x PRO-E32 - 125	150	125	98	50	50	M16 x 2.0P	2 ~ 20	1.50
5100-529-032-150	HSK50E x PRO-E32 - 150	175	150	123	50	50	M16 x 2.0P	2 ~ 20	1.87

Features:

- ▶ Superior interchangeability with ER collets.
- ▶ Assembled with ER spring collet (15µm, 10µm, 5µm), ERS metallic sealed collet (10µm, 7µm, 5µm, 3µm) and ERS coolant FOD collet (10µm, 7µm, 5µm, 3µm).
- ▶ The design of enlarged holder ID hole optimizes the coverage of ER collet, shortens the tool overhanging length, and improves runout accuracy and machining stability.
- ▶ The design of straight parts above and below the thread makes PRO-E tool holders have better contact with clamping nuts to achieve higher runout accuracy.
- ▶ PRO-E nuts without slots reduce the wind shear at high speed

Product information:

- ▶ Higher balancing grade and revolution can be done upon request but additional charge is needed.

Standard Accessory: • NUT

Collet	Nut	Coolant Supply Unit	Key	Spanner	Preset Screw
P.X-18~38	P.X-53	P.X-70	P.X-70	PX-73、75、82	P.X-111



HSK / ER COLLET CHUCK



HSK / ER 立銑刀夾頭

(DIN ISO 15488)

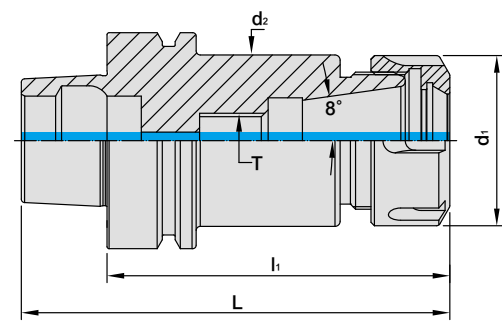
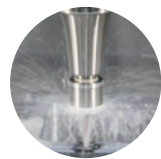

MODEL NO.	TYPE	L	l ₁	d ₁	d ₂ MAX.	T	SIZE RANGE	WEIGHT (KGS)
5099-108-016-065	HSK40E x ER16A - 65	85	65	28	34	-	1 ~ 10	0.35
5099-108-020-060	HSK40E x ER20A - 60	80	60	34	34	-	1 ~ 13	0.35
5099-108-020-100	HSK40E x ER20A - 100	120	100	34	34	M10 x 1.5P	1 ~ 13	0.45
5099-110-025-075	HSK40E x ER25 - 75	95	75	42	34	M10 x 1.5P	1 ~ 16	0.40
5099-110-032-100	HSK40E x ER32 - 100	120	100	50	34	-	2 ~ 20	0.92
5100-108-016-080	HSK50E x ER16A - 80	105	80	28	42	M10 x 1.5P	1 ~ 10	0.50
5100-108-020-080	HSK50E x ER20A - 80	105	80	34	42	M12 x 1.75P	1 ~ 13	0.60
5100-110-032-085	HSK50E x ER32 - 85	110	85	50	42	-	2 ~ 20	1.30
5101-110-032-090	HSK63E x ER32 - 90	122	90	50	53	M16 x 2.0P	2 ~ 20	2.50
5101-110-040-085	HSK63E x ER40 - 85	117	85	63	53	-	3 ~ 26	2.65
5101-110-040-120	HSK63E x ER40 - 120	152	120	63	53	-	3 ~ 26	2.77

Features:

- ▶ According to DIN ISO 15488.
- ▶ This ER collet chuck has superior flexibility for use with all tool types, e.g. drills, taps, mills, reamers.
- ▶ It is recommended to tighten the clamping nuts using a torque wrench. Please refer to the catalogue page of ER POWER GOOD NUT.

Product information:

- ▶ Higher balancing grade and revolution can be done upon request but additional charge is needed.

Standard Accessory: • NUT

Collet	Nut	Coolant Supply Unit	Key	Spanner	Preset Screw
P.X-18~38	P.X-54~58	P.X-70	P.X-70	PX-73~74、79	P.X-111



HSK / SKX COLLET CHUCK



HSK / SKX 立銑刀夾頭

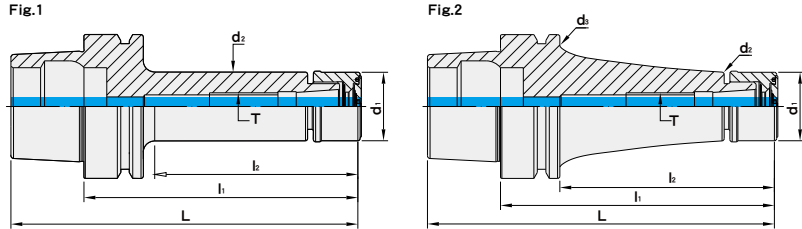

MODEL NO.	TYPE	L	l ₁	l ₂	d ₁	d ₂	d ₃	T	SIZE RANGE	Fig.	WEIGHT (KGS)
5097-790-006-045	HSK25E x SKX6 - 45	58	45	34	19.5	19.5	-	-	1 ~ 6	1	0.10
5097-790-010-055	HSK25E x SKX10 - 55	68	55	35	30	30	-	-	2 ~ 10	1	0.18
5098-790-006-060	HSK32E x SKX6 - 60	76	60	36	19.5	19.5	-	-	1 ~ 6	1	0.17
5098-790-010-060	HSK32E x SKX10 - 60	76	60	40	30	26	-	-	2 ~ 10	1	0.26
5098-790-010-075	HSK32E x SKX10 - 75	91	75	40	30	30	-	M6 x 1.0P	2 ~ 10	1	0.30
5099-790-006-060	HSK40E x SKX6 - 60	80	60	35	19.5	19.5	-	-	1 ~ 6	1	0.28
5099-790-010-060	HSK40E x SKX10 - 60	80	60	38	30	30	-	-	2 ~ 10	1	0.40
5099-790-010-075	HSK40E x SKX10 - 75	95	75	53	30	30	-	M6 x 1.0P	2 ~ 10	1	0.50
5099-790-016-080	HSK40E x SKX16 - 80	100	80	45	40	40	-	-	2 ~ 16	1	0.60
5100-790-006-060	HSK50E x SKX6 - 60	85	60	29	19.5	19.5	-	-	1 ~ 6	1	0.50
5100-790-006-080	HSK50E x SKX6 - 80	105	80	49	19.5	19.5	-	M6 x 1.0P	1 ~ 6	1	0.60
5100-790-010-060	HSK50E x SKX10 - 60	85	60	29	30	30	-	-	2 ~ 10	1	0.50
5100-790-010-105	HSK50E x SKX10 - 105	130	105	74	30	30	-	M10 x 1.5P	2 ~ 10	1	0.70
5100-790-016-080	HSK50E x SKX16 - 80	105	80	53	40	40	-	-	2 ~ 16	1	0.60
5100-790-016-120	HSK50E x SKX16 - 120	145	120	93	40	40	-	M16 x 2.0P	2 ~ 16	1	1.10
5101-790-006-100	HSK63E x SKX6 - 100	132	100	69	19.5	19.5	-	M6 x 1.0P	1 ~ 6	1	0.90
5101-790-006-120	HSK63E x SKX6 - 120	152	120	94	19.5	19.5	53	M6 x 1.0P	1 ~ 6	2	1.00
5101-790-010-105	HSK63E x SKX10 - 105	137	105	74	30	30	-	M10 x 1.5P	2 ~ 10	1	1.30
5101-790-010-120	HSK63E x SKX10 - 120	152	120	94	30	30	53	M10 x 1.5P	2 ~ 10	2	1.50
5101-790-010-150	HSK63E x SKX10 - 150	182	150	124	30	30	53	M10 x 1.5P	2 ~ 10	2	1.70
5101-790-016-120	HSK63E x SKX16 - 120	152	120	89	40	40	-	M18 x 1.5P	2 ~ 16	1	1.70
5101-790-016-150	HSK63E x SKX16 - 150	182	150	124	40	40	53	M18 x 1.5P	2 ~ 16	2	1.80
5101-790-020-120	HSK63E x SKX20 - 120	152	120	92	48	48.5	-	M22 x 1.5P	3 ~ 20	1	1.80
5101-790-020-135	HSK63E x SKX20 - 135	167	135	107	48	48.5	-	M22 x 1.5P	3 ~ 20	1	2.00
5101-790-025-135	HSK63E x SKX25 - 135	167	135	108	55	52	-	M28 x 2.0P	3 ~ 25.4	1	1.90

Features:

- ▶ Higher clamping force and precision stability than 8° ER design due to 4° taper angle collet design.
- ▶ SKX sealed nuts are capable of coolant pressure up to 70bar.
- ▶ Nuts in smaller OD and without slots are suitable for high-speed machining with less interference.
- ▶ Shorter overhanging tool length, better rigidity.
- ▶ SKX tool holders of the length over 120mm have curved line design for better rigidity.

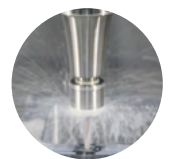

Standard Accessory: • NUT

Collet	Nut	Sealed Cap	Coolant Supply Unit	Key	Spanner	Sealed Cap Spanner	Easy Carry Spanner	Preset Screw
P.X-39~40	P.X-59	P.X-60	P.X-70	P.X-70	P.X-73、75、82	P.X-80	P.X-80	P.X-111



HSK / SK3 COLLET CHUCK

5 μ m

BALANCE
G2.5
25,000 RPM

HSK / SK3 高速機專用夾頭

(DIN 69893-5)

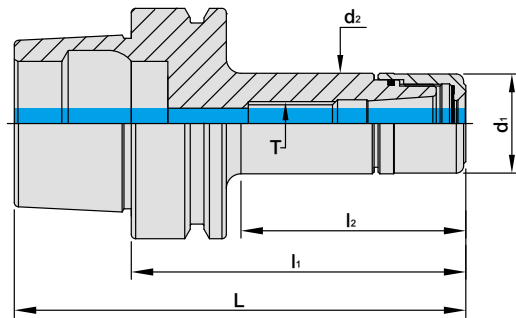

MODEL NO.	TYPE	L	l ₁	l ₂	d ₁	d ₂	T	SIZE RANGE	WEIGHT (KGS)
5097-763-006-040	HSK25E x SK306 - 40	53	40	29	19.5	19.5	-	1 ~ 6	0.50
5097-763-006-060	HSK25E x SK306 - 60	73	60	49	19.5	19.5	M8 x 1.25P	1 ~ 6	0.70
5098-763-006-045	HSK32E x SK306 - 45	61	45	24	19.5	16.5	-	1 ~ 6	0.50
5098-763-006-060	HSK32E x SK306 - 60	76	60	38	19.5	19.5	M8 x 1.25P	1 ~ 6	0.70
5099-763-006-045	HSK40E x SK306 - 45	65	45	24	19.5	19.5	-	1 ~ 6	0.70
5099-763-006-060	HSK40E x SK306 - 60	80	60	38	19.5	19.5	M8 x 1.25P	1 ~ 6	0.80
5099-763-006-075	HSK40E x SK306 - 75	95	75	53	19.5	19.5	M8 x 1.25P	1 ~ 6	0.90
5099-763-010-060	HSK40E x SK310 - 60	80	60	38	27.5	27.5	-	2 ~ 10	0.90
5099-763-010-075	HSK40E x SK310 - 75	95	75	53	27.5	27.5	M12 x 1.75P	2 ~ 10	1.00
5099-763-013-060	HSK40E x SK313 - 60	80	60	39	33	33	-	2 ~ 13	0.90
5099-763-013-075	HSK40E x SK313 - 75	95	75	54	33	33	-	2 ~ 13	1.00
5099-763-016-075	HSK40E x SK316 - 75	95	75	40	40	40	-	2 ~ 16	1.00
5100-763-006-060	HSK50E x SK306 - 60	85	60	32	19.5	19.5	-	1 ~ 6	1.00
5100-763-006-075	HSK50E x SK306 - 75	100	75	44	19.5	19.5	M8 x 1.25P	1 ~ 6	1.20
5100-763-006-090	HSK50E x SK306 - 90	115	90	59	19.5	19.5	M8 x 1.25P	1 ~ 6	1.40
5100-763-010-060	HSK50E x SK310 - 60	85	60	33	27.5	27.5	-	2 ~ 10	0.90
5100-763-010-075	HSK50E x SK310 - 75	100	75	44	27.5	27.5	M12 x 1.75P	2 ~ 10	1.00
5100-763-010-090	HSK50E x SK310 - 90	115	90	59	27.5	27.5	M12 x 1.75P	2 ~ 10	1.20
5100-763-013-065	HSK50E x SK313 - 65	90	65	36	33	33	-	2 ~ 13	0.90
5100-763-013-075	HSK50E x SK313 - 75	100	75	46	33	33	M12 x 1.75P	2 ~ 13	1.00
5100-763-013-090	HSK50E x SK313 - 90	115	90	61	33	33	M12 x 1.75P	2 ~ 13	1.20
5100-763-016-075	HSK50E x SK316 - 75	100	75	48	40	40	-	2 ~ 16	1.00
5100-763-016-090	HSK50E x SK316 - 90	115	90	63	40	40	M18 x 1.5P	2 ~ 16	1.20

Features:

- ▶ Using 4° taper angle collets achieves higher clamping power and stability than 8° design of the ER system.
- ▶ Smaller OD nuts without slots are ideal for high-speed machining with less interference.
- ▶ Dustproof design of adding O rings prevents metal chips and coolants from getting into tool holders.

Product information:

- ▶ Higher balancing grade and revolution can be done upon request but additional charge is needed.

Standard Accessory: • NUT

Collet	Nut	Coolant Supply Unit	Key	Spanner	Preset Screw
P.X-39~41	P.X-58	P.X-70	P.X-70	P.X-73、75、82	P.X-111



HSK / SBL SLIM-FIT COLLET CHUCK



HSK / SBL 後拉式立銑刀夾頭

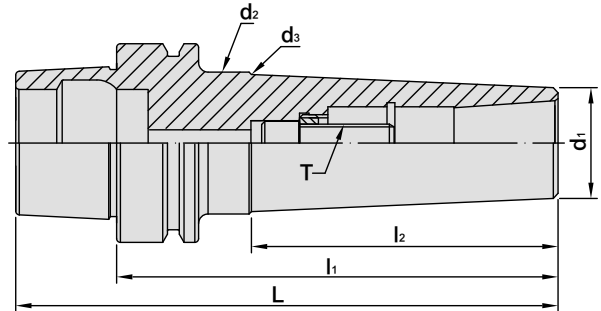

MODEL NO.	TYPE	L	l ₁	l ₂	d ₁	d ₂	d ₃	T	RECOMMENDED TORQUE		SIZE RANGE	WEIGHT (KGS)
									N.m	1bf-ft		
5099-648-006-070	HSK40ExSBL6-70	90	70	45	14	18	-	M6x1.0P	12	9	3~6	0.27
5100-648-006-080	HSK50E x SBL6 - 80	105	80	44	14	18	-	M6 x 1.0P	12	9	3 ~ 6	1.40
5100-648-006-120	HSK50E x SBL6 - 120	145	120	84	14	22	-	M6 x 1.0P	12	9	3 ~ 6	1.50
5100-648-012-110	HSK50E x SBL12 - 110	135	110	65	26	42	36	M10 x 1.5P	45	33	3 ~ 12	1.50
5100-648-012-130	HSK50E x SBL12 - 130	155	130	86	26	42	39	M10 x 1.5P	45	33	3 ~ 12	1.85
5100-648-020-120	HSK50E x SBL20 - 120	145	120	93	35	42	-	M12 x 1.75P	60	44	3 ~ 20	1.80
5100-648-020-150	HSK50E x SBL20 - 150	175	150	123	35	42	-	M12 x 1.75P	60	44	3 ~ 20	2.00
5101-648-006-080	HSK63E x SBL6 - 80	112	80	39	14	18	-	M6 x 1.0P	12	9	3 ~ 6	1.70
5101-648-006-120	HSK63E x SBL6 - 120	152	120	79	14	22	-	M6 x 1.0P	12	9	3 ~ 6	1.90
5101-648-008-130	HSK63E x SBL8 - 130	162	130	94	20	29	-	M8 x 1.25P	29	21	3 ~ 8	0.99
5101-648-008-150	HSK63E x SBL8 - 150	182	150	114	20	32	-	M8 x 1.25P	29	21	3 ~ 8	1.11
5101-648-012-110	HSK63E x SBL12 - 110	142	110	79	26	37	-	M10 x 1.5P	45	33	3 ~ 12	1.80
5101-648-012-150	HSK63E x SBL12 - 150	182	150	119	26	42	-	M10 x 1.5P	45	33	3 ~ 12	2.00
5101-648-020-120	HSK63E x SBL20 - 120	152	120	89	35	42	-	M12 x 1.75P	60	44	3 ~ 20	2.00
5101-648-020-140	HSK63E x SBL20 - 140	172	140	97	35	45	43	M12 x 1.75P	60	44	3 ~ 20	2.45
5108-648-006-120	HSK100E x SBL6 - 120	170	120	76	14	22	-	M6 x 1.0P	12	9	3 ~ 6	2.15
5108-648-008-130	HSK100E x SBL8 - 130	180	130	86	20	29	-	M8 x 1.25P	29	21	3 ~ 8	2.31
5108-648-008-150	HSK100E x SBL8 - 150	200	150	106	20	31	-	M8 x 1.25P	29	21	3 ~ 8	2.43
5108-648-012-120	HSK100E x SBL12 - 120	170	120	81	26	37	-	M10 x 1.5P	45	33	3 ~ 12	2.40
5108-648-020-135	HSK100E x SBL20 - 135	185	135	88	35	45	42	M12 x 1.75P	60	44	3 ~ 20	2.74
5108-648-025-150	HSK100E x SBL25 - 150	200	150	111	40	49	-	M16 x 1.5P	90	66	3 ~ 25	2.80

Features:

- ▶ The design of non-clamping nut and slim front ends reduces interference, ideal for deep hole machining.
- ▶ Taper angle 4° increases the stability of clamping precision.
- ▶ T.I.R. is within 5µm at 4D distance.

Product information:

- ▶ Higher balancing grade and revolution can be done upon request but additional charge is needed.

Collet	Spanner	Screw
P.X-42	P.X-80	P.X-114



HSK / SBLC SLIM-FIT COLLET CHUCK

5 μ m

BALANCE
G2.5
25,000 RPM

HSK / SBLC 後拉式立銑刀夾頭

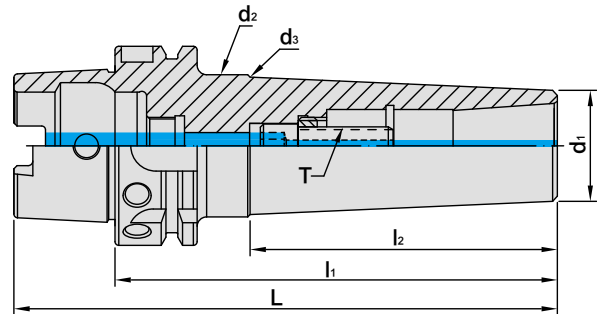
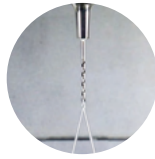

MODEL NO.	TYPE	L	l ₁	l ₂	d ₁	d ₂	d ₃	T	RECOMMENDED TORQUE		SIZE RANGE	WEIGHT (KGS)
									N.m	1bf-ft		
5099-623-006-070	HSK40ExSBLC6-70	90	70	45	14	18	-	M6x1.0P	12	9	3~6	0.27
5100-623-006-080	HSK50ExSBLC6-80	105	80	44	14	18	-	M6x1.0P	12	9	3~6	1.40
5100-623-006-120	HSK50ExSBLC6-120	145	120	84	14	22	-	M6x1.0P	12	9	3~6	1.50
5100-623-012-110	HSK50ExSBLC12-110	135	110	65	26	42	36	M10x1.5P	45	33	3~12	1.50
5100-623-012-130	HSK50ExSBLC12-130	155	130	86	26	42	39	M10x1.5P	45	33	3~12	1.85
5100-623-020-120	HSK50ExSBLC20-120	145	120	93	35	42	-	M12x1.75P	60	44	3~20	1.80
5100-623-020-150	HSK50ExSBLC20-150	175	150	123	35	42	-	M12x1.75P	60	44	3~20	2.00
5101-623-006-080	HSK63ExSBLC6-80	112	80	39	14	18	-	M6x1.0P	12	9	3~6	1.70
5101-623-006-120	HSK63ExSBLC6-120	152	120	79	14	22	-	M6x1.0P	12	9	3~6	1.90
5101-623-008-130	HSK63ExSBLC8-130	162	130	94	20	29	-	M8x1.25P	29	21	3~8	0.99
5101-623-008-150	HSK63ExSBLC8-150	182	150	114	20	32	-	M8x1.25P	29	21	3~8	1.11
5101-623-012-110	HSK63ExSBLC12-110	142	110	79	26	37	-	M10x1.5P	45	33	3~12	1.80
5101-623-012-150	HSK63ExSBLC12-150	182	150	119	26	42	-	M10x1.5P	45	33	3~12	2.00
5101-623-020-120	HSK63ExSBLC20-120	152	120	89	35	42	-	M12x1.75P	60	44	3~20	2.00
5101-623-020-140	HSK63ExSBLC20-140	172	140	97	35	45	43	M12x1.75P	60	44	3~20	2.45
5108-623-006-120	HSK100ExSBLC6-120	170	120	76	14	22	-	M6x1.0P	12	9	3~6	2.15
5108-623-008-130	HSK100ExSBLC8-130	180	130	86	20	29	-	M8x1.25P	29	21	3~8	2.31
5108-623-008-150	HSK100ExSBLC8-150	200	150	106	20	31	-	M8x1.25P	29	21	3~8	2.43
5108-623-012-120	HSK100ExSBLC12-120	170	120	81	26	37	-	M10x1.5P	45	33	3~12	2.40
5108-623-020-135	HSK100ExSBLC20-135	185	135	88	35	45	42	M12x1.75P	60	44	3~20	2.74
5108-623-025-150	HSK100ExSBLC25-150	200	150	111	40	49	-	M16x1.5P	90	66	3~25	2.80

Features:

- ▶ SBLC collet chuck used for center coolant improves the metal chip removal capability and the surface finish of the workpiece.
- ▶ The design of non-clamping nut and slim front ends reduces interference, ideal for deep hole machining.
- ▶ T.I.R. is within 5 μ m at 4D distance.
- ▶ Taper angle 4° increases the stability of clamping precision.

Product information:

- ▶ Higher balancing grade and revolution can be done upon request but additional charge is needed.
- ▶ Used with SLC sealed collet and coolant through cutters.

Standard Accessory: • SPANNER

Collet	Coolant Supply Unit	Key	Spanner	Screw
P.X-43	P.X-70	P.X-70	P.X-80	P.X-114



HSK BLANK

HSK 素材

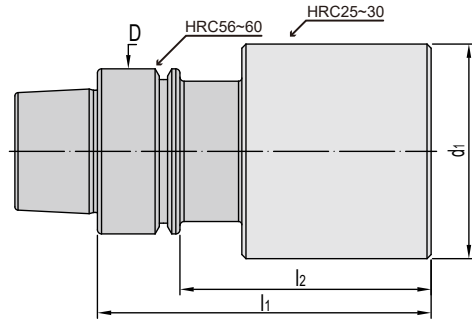

MODEL NO.	TYPE	D	d ₁	l ₁	l ₂	WEIGHT (KGS)
5098-001-066-044	HSK32E x Ø66 - 44	32	66	44	24	0.41
5099-001-052-150	HSK40E x Ø52 - 150	40	52	150	130	2.23

Features:

- Blanks can be machined according to customer demands. It is not recommended to do heat treatment after machining.



REFERENCE DETAILS

DIN 69893 - 6

- ▶ Shank body standard: **DIN 69893 - 6**
- ▶ Taper tolerance < **AT3**
- ▶ Hardness > **HRC 56°**
- ▶ Surface roughness: Ra < **0.25 µm**
- ▶ Roundness < **0.6 µm**
- ▶ Carbon depth > **0.8mm**
- ▶ The shank has pre-balance at G6.3, and can provide precision balance at G2.5. It can be ordered by request.

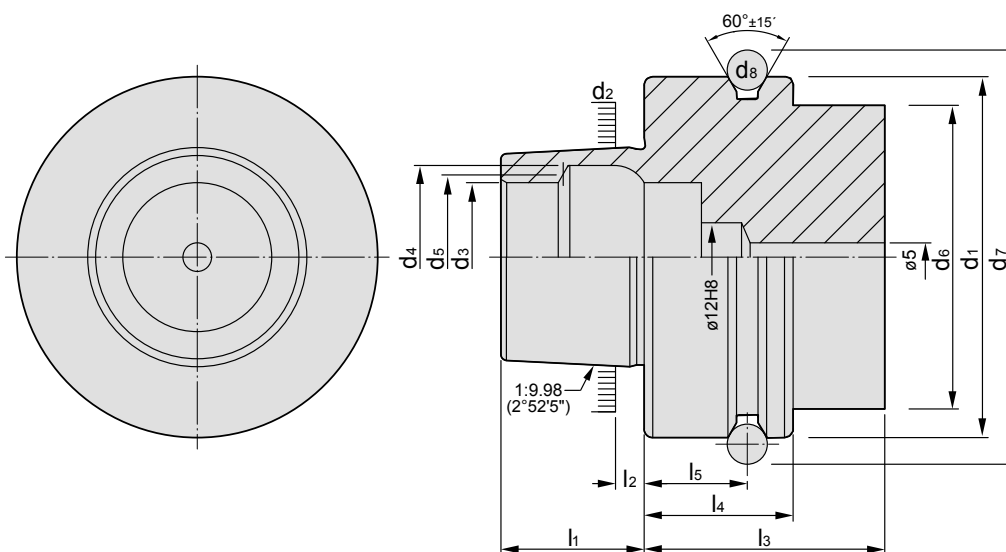

FROM F

HSK	d ₁ h10	d ₂	d ₃ H10	d ₄ H11	d ₅	d ₆ max.	d ₇ 0 -0.1
50	50	30.007	21	25.5	23	42	59.3
63	63	38.009	26	32	29	53	72.3
HSK	d ₈	l ₁ 0 -0.2	l ₂	l ₃ min.	l ₄ 0 -0.1	l ₅ ±0.1	
50	7	20	4	42	26	18	
63	7	25	5	42	26	18	



HSK / PRO-E COLLET CHUCK



HSK / PRO-E 筒夾式刀桿

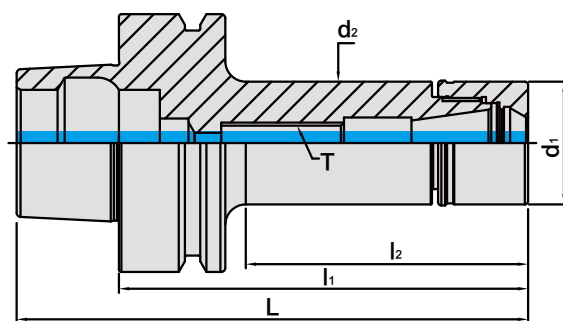

MODEL NO.	TYPE	L	l ₁	l ₂	d ₁	d ₂	T	SIZE RANGE	WEIGHT (KGS)
5103-529-016-070	HSK63F x PRO-E16 - 70	95	70	39	30	30	-	1 ~ 10	0.82
5103-529-016-100	HSK63F x PRO-E16 - 100	125	100	69	30	30	M10 x 1.5P	1 ~ 10	0.97
5103-529-016-125	HSK63F x PRO-E16 - 125	150	125	94	30	30	M10 x 1.5P	1 ~ 10	1.10
5103-529-020-070	HSK63F x PRO-E20 - 70	95	70	39	35	35	-	1 ~ 13	0.88
5103-529-020-100	HSK63F x PRO-E20 - 100	125	100	69	35	35	M12 x 1.75P	1 ~ 13	1.09
5103-529-020-125	HSK63F x PRO-E20 - 125	150	125	94	35	35	M12 x 1.75P	1 ~ 13	1.27
5103-529-020-150	HSK63F x PRO-E20 - 150	175	150	119	35	35	M12 x 1.75P	1 ~ 13	1.45
5103-529-025-070	HSK63F x PRO-E25 - 70	95	70	41	42	42	-	1 ~ 16	0.97
5103-529-025-100	HSK63F x PRO-E25 - 100	125	100	71	42	42	M16 x 2.0P	1 ~ 16	1.26
5103-529-025-125	HSK63F x PRO-E25 - 125	150	125	96	42	42	M16 x 2.0P	1 ~ 16	1.52
5103-529-032-070	HSK63F x PRO-E32 - 70	95	70	41	50	50	-	2 ~ 20	1.00
5103-529-032-100	HSK63F x PRO-E32 - 100	125	100	71	50	50	M16 x 2.0P	2 ~ 20	1.38
5103-529-032-125	HSK63F x PRO-E32 - 125	150	125	96	50	50	M16 x 2.0P	2 ~ 20	1.70
5103-529-032-150	HSK63F x PRO-E32 - 150	175	150	121	50	50	M16 x 2.0P	2 ~ 20	2.04

Features:

- ▶ Superior interchangeability with ER collets.
- ▶ Assembled with ER spring collet (15µm, 10µm, 5µm), ERS metallic sealed collet (10µm, 7µm, 5µm, 3µm) and ERS coolant FOD collet (10µm, 7µm, 5µm, 3µm).
- ▶ The design of enlarged holder ID hole optimizes the coverage of ER collet, shortens the tool overhanging length, and improves runout accuracy and machining stability.
- ▶ The design of straight parts above and below the thread makes PRO-E tool holders have better contact with clamping nuts to achieve higher runout accuracy.
- ▶ PRO-E nuts without slots reduce the wind shear at high speed

Product information:

- ▶ Higher balancing grade and revolution can be done upon request but additional charge is needed.

Standard Accessory: • NUT

Collet	Nut	Spanner	Preset Screw
P.X18~38	P.X-53	P.X-73、75、82	P.X-111



HSK / ER COLLET CHUCK



HSK / ER 立銑刀夾頭

(DIN 69893-6)
(ISO 15488)

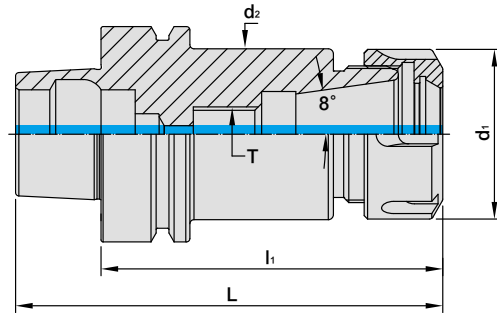

MODEL NO.	TYPE	L	l ₁	d ₁	d ₂ MAX.	T	SIZE RANGE	WEIGHT (KGS)
5102-108-016-080	HSK50F x ER16A - 80	100	80	28	42	M10 x 1.5P	1 ~ 10	0.50
5102-108-016-100	HSK50F x ER16A - 100	120	100	28	42	M10 x 1.5P	1 ~ 10	0.55
5102-108-016-120	HSK50F x ER16A - 120	140	120	28	42	M10 x 1.5P	1 ~ 10	0.70
5102-108-020-080	HSK50F x ER20A - 80	100	80	34	42	M12 x 1.75P	1 ~ 13	0.60
5102-108-020-100	HSK50F x ER20A - 100	120	100	34	42	M12 x 1.75P	1 ~ 13	0.65
5102-108-020-120	HSK50F x ER20A - 120	140	120	34	42	M12 x 1.75P	1 ~ 13	0.70
5102-110-025-080	HSK50F x ER25 - 80	100	80	42	42	M16 x 2.0P	1 ~ 16	0.70
5102-110-025-100	HSK50F x ER25 - 100	120	100	42	42	M16 x 2.0P	1 ~ 16	0.80
5102-110-025-135	HSK50F x ER25 - 135	155	135	42	42	M16 x 2.0P	1 ~ 16	0.90
5102-110-032-100	HSK50F x ER32 - 100	120	100	50	42	M16 x 2.0P	2 ~ 20	1.35
5102-110-032-135	HSK50F x ER32 - 135	155	135	50	42	M16 x 2.0P	2 ~ 20	1.50
5102-110-032-160	HSK50F x ER32 - 160	180	160	50	42	M16 x 2.0P	2 ~ 20	1.70

Features:

- ▶ According to ISO 15488.
- ▶ This ER collet chuck has superior flexibility for use with all tool types, e.g. drills, taps, mills, reamers.
- ▶ It is recommended to tighten the clamping nuts using a torque wrench. Please refer to the catalogue page of ER POWER GOOD NUT.

Product information:

- ▶ Higher balancing grade and revolution can be done upon request but additional charge is needed.

Standard Accessory: • NUT

Collet	Nut	Spanner	Preset Screw
P.X-18~38	P.X-54~58	PX-73~76、79、82	P.X-111



HSK / ER COLLET CHUCK



HSK / ER 立銑刀夾頭

(ISO 15488)

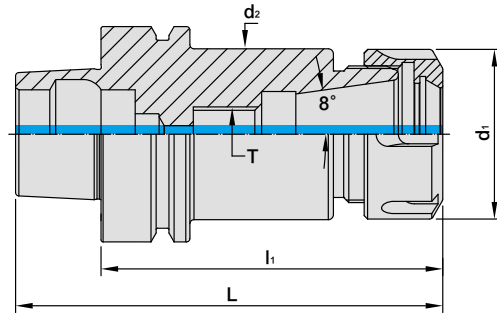

MODEL NO.	TYPE	L	l ₁	d ₁	d ₂ MAX.	T	SIZE RANGE	WEIGHT (KGS)
5103-108-016-080	HSK63F x ER16A - 80	105	80	28	53	M10 x 1.5P	1 ~ 10	1.50
5103-108-016-100	HSK63F x ER16A - 100	125	100	28	53	M10 x 1.5P	1 ~ 10	1.55
5103-108-016-120	HSK63F x ER16A - 120	145	120	28	53	M10 x 1.5P	1 ~ 10	1.70
5103-108-016-160	HSK63F x ER16A - 160	185	160	28	53	M10 x 1.5P	1 ~ 10	1.90
5103-108-020-080	HSK63F x ER20A - 80	105	80	34	53	M12 x 1.75P	1 ~ 13	1.60
5103-108-020-100	HSK63F x ER20A - 100	125	100	34	53	M12 x 1.75P	1 ~ 13	1.70
5103-108-020-120	HSK63F x ER20A - 120	145	120	34	53	M12 x 1.75P	1 ~ 13	1.80
5103-108-020-160	HSK63F x ER20A - 160	185	160	34	53	M12 x 1.75P	1 ~ 13	2.00
5103-110-025-080	HSK63F x ER25 - 80	105	80	42	53	M16 x 2.0P	1 ~ 16	1.70
5103-110-025-100	HSK63F x ER25 - 100	125	100	42	53	M16 x 2.0P	1 ~ 16	1.80
5103-110-025-120	HSK63F x ER25 - 120	145	120	42	53	M16 x 2.0P	1 ~ 16	2.00
5103-110-025-150	HSK63F x ER25 - 150	175	150	42	53	M16 x 2.0P	1 ~ 16	2.30
5103-110-032-070	HSK63F x ER32 - 70	95	70	50	53	-	2 ~ 20	2.50
5103-110-032-100	HSK63F x ER32 - 100	125	100	50	53	M16 x 2.0P	2 ~ 20	2.55
5103-110-032-145	HSK63F x ER32 - 145	170	145	50	53	M16 x 2.0P	2 ~ 20	2.70
5103-110-032-160	HSK63F x ER32 - 160	185	160	50	53	M16 x 2.0P	2 ~ 20	3.10
5103-110-040-075	HSK63F x ER40 - 75	100	75	63	53	-	3 ~ 26	2.65
5103-110-040-100	HSK63F x ER40 - 100	125	100	63	53	M20 x 2.0P	3 ~ 26	2.70
5103-110-040-120	HSK63F x ER40 - 120	145	120	63	53	M20 x 2.0P	3 ~ 26	2.77
5103-110-040-150	HSK63F x ER40 - 150	175	150	63	53	M20 x 2.0P	3 ~ 26	2.95
5103-110-040-170	HSK63F x ER40 - 170	195	170	63	53	M20 x 2.0P	3 ~ 26	3.10
5103-110-050-120	HSK63F x ER50 - 120	145	120	78	53	M24 x 2.0P	6 ~ 34	3.50

Features:

- ▶ According to ISO 15488.
- ▶ This ER collet chuck has superior flexibility for use with all tool types, e.g. drills, taps, mills, reamers.
- ▶ It is recommended to tighten the clamping nuts using a torque wrench. Please refer to the catalogue page of ER POWER GOOD NUT.

Product information:

- ▶ Higher balancing grade and revolution can be done upon request but additional charge is needed.

Standard Accessory: • NUT

Collet	Nut	Preset Screw	Spanner
P.X-18~38	P.X-54~58	P.X-111	PX-73~76、79、82



HSK / SKX COLLET CHUCK



HSK / SKX 立銑刀夾頭



Fig.1

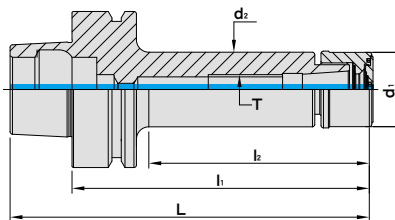
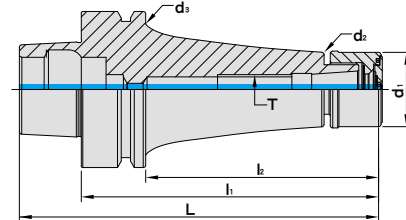

Fig.2



MODEL NO.	TYPE	L	l ₁	l ₂	d ₁	d ₂	d ₃	T	SIZE RANGE	Fig.	WEIGHT (KGS)
5103-790-010-090	HSK63F x SKX10 - 90	115	90	60	30	30	-	M12 x 1.75P	2 ~ 10	1	0.86
5103-790-010-105	HSK63F x SKX10 - 105	130	105	75	30	30	-	M12 x 1.75P	2 ~ 10	1	0.94
5103-790-016-090	HSK63F x SKX16 - 90	115	90	59	40	40	-	M18 x 1.5P	2 ~ 16	1	0.96
5103-790-016-105	HSK63F x SKX16 - 105	130	105	74	40	40	-	M18 x 1.5P	2 ~ 16	1	1.08
5103-790-016-120	HSK63F x SKX16 - 120	145	120	94	40	40	53	M18 x 1.5P	2 ~ 16	2	1.30
5103-790-020-120	HSK63F x SKX20 - 120	145	120	93	48	48.5	-	M22 x 1.5P	3 ~ 20	1	1.50
5103-790-025-090	HSK63F x SKX25 - 90	115	90	63	52	55	-	-	3 ~ 25.4	1	1.12

Features:

- ▶ Higher clamping force and precision stability than 8° ER design due to 4° taper angle collet design.
- ▶ SKX sealed nuts are capable of coolant pressure up to 70bar.
- ▶ Nuts in smaller OD and without slots are suitable for high-speed machining with less interference.
- ▶ Shorter overhanging tool length, better rigidity.
- ▶ SKX tool holders of the length over 120mm have curved line design for better rigidity.

Standard Accessory: • NUT

Collet	Nut	Sealed Cap	Spanner	Sealed Cap Spanner	Easy Carry Spanner	Preset Screw
P.X-39~40	P.X-59	P.X-60	P.X-73、75、82	P.X-80	P.X-80	P.X-111

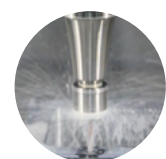

HSK BLANK

HSK 素材

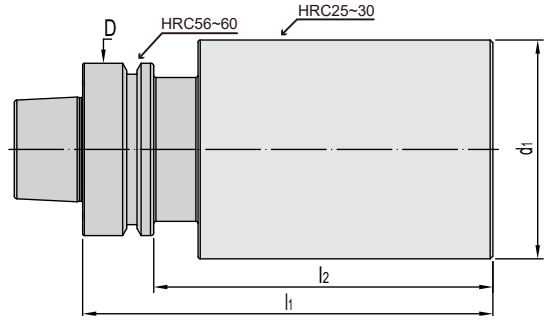

MODEL NO.	TYPE	D	d ₁	l ₁	l ₂	WEIGHT (KGS)
5103-001-080-250	HSK63F x Ø80 - 250	63	80	250	224	9.12

Features:

- Blanks can be machined according to customer demands. It is not recommended to do heat treatment after machining.



REFERENCE DETAILS

DIN ISO 12164 - 3

- ▶ Shank body standard: **ISO-12164-3:2014**
- ▶ Taper tolerance < **AT3**
- ▶ Hardness > **HRC 56°**
- ▶ Surface roughness: Ra < **0.25 μm**
- ▶ Roundness < **0.8 μm**
- ▶ Carbon depth > **0.8mm**
- ▶ The shank has pre-balance at G6.3, and can provide precision balance at G2.5. It can be ordered by request.

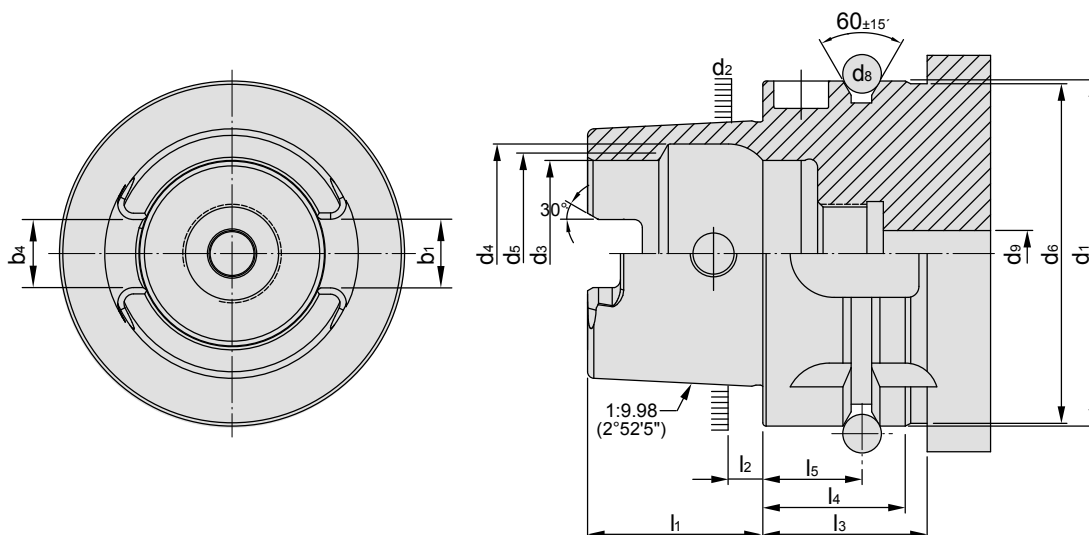

FROM T

HSK	d ₁ h10	d ₂	d ₃ H10	d ₄ H11	d ₅	d ₆ max.	d ₈	d ₉ max.
32	32	24.007	17	20.5	19	31	4	4.2
40	40	30.007	21	25.5	23	39	4	5
50	50	38.009	26	32	29	49	7	6.8
63	63	48.010	34	40	37	62	7	8.4
80	80	60.012	42	50	46	79	7	10.2
100	100	75.013	53	63	58	99	7	12
HSK	l ₁ 0 -0.2	l ₂	l ₃ min.	l ₄ 0 -0.1	l ₅ ±0.1	b ₁ +0.04 -0.04	b ₄	
32	16	3.2	23	20	16	7.05	6.932	
40	20	4	23	20	16	8.05	7.932	
50	25	5	30	26	18	10.54	10.425	
63	32	6.3	30	26	18	12.54	12.425	
80	40	8	30	26	18	16.04	15.93	
100	50	10	34	29	20	20.02	19.91	



DESIGNATION OF HSK-T TURNING TOOLS

HSK-T 編碼原則

CLAMP MECHANISM			
A	Back clamp system	M	Multi-clamp system
C	Clamp-on system	P	Pin lock system
D	Double clamp system	S	Screw-on system
E	Off-set pin system	T	Taper lock system
JS	Screw-on system	W	Wedge-on system
JT	Back clamp system		

INSERT CLEARANCE	
A	3°
B	5°
C	7°
D	15°
E	20°
F	25°
G	30°
N	0°
P	11°

INSERT EDGE LENGTH					
Insert inscribed circle	6.35	7.94	9.525	12.00	12.70
80°	06	08	09	-	12
55°	07	-	11	-	15
35°	11	-	16	-	-
	-	-	-	12	-
	11	13	16	-	22
	-	-	09	-	12

HSK - T63 - M C L N R - 45 065 - 12

INSERT GEOMETRY		
C		80°
D		55°
K		55°
R		
S		
T		
V		35°
W		80°
L		
H		120°
A		85°
B		82°
E		75°
M		86°
O		135°
P		108°

CUTTING EDGE GEOMETRY			
A - 90°		M - 50°	
B - 75°		N - 63°	
C - 90°		P - 117.5°	
D - 45°		R - 75°	
E - 60°		S - 45°	
F - 90°		T - 60°	
G - 90°		U - 93°	
H - 107.5°		V - 72.5°	
J - 93°		W - 60°	
K - 75°		Y - 85°	
L - 95°			

HAND
R
L
N

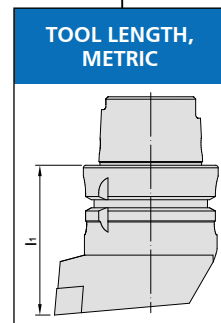
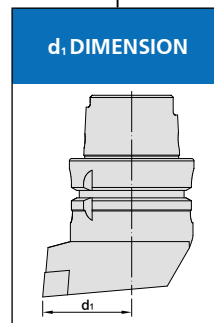

MCLN EXTERNAL TURNING TOOL

MCLN 外徑車刀

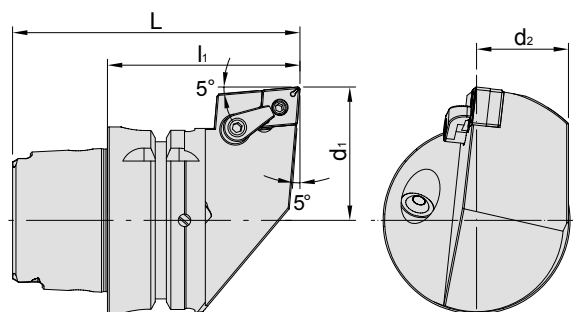



MODEL NO.	TYPE	L	l ₁	d ₁	d ₂	Insert	WEIGHT (KGS)
573T.475.12R.065	HSK-T63 - MCLNR - 45065 - 12	97	65	45	31	CN..1204	1.26
573T.475.12L.065	HSK-T63 - MCLNL - 45065 - 12	97	65	45	31	CN..1204	1.26

Product information:

► Inserts are optional accessories. Needs to be purchased additionally.

Accessory:

Insert	Clamp	Shim	Screw	Screw
				
CN..1204	MC620	SMC432	MS630	MLP46L-A

MDJN EXTERNAL TURNING TOOL

MDJN 外徑車刀

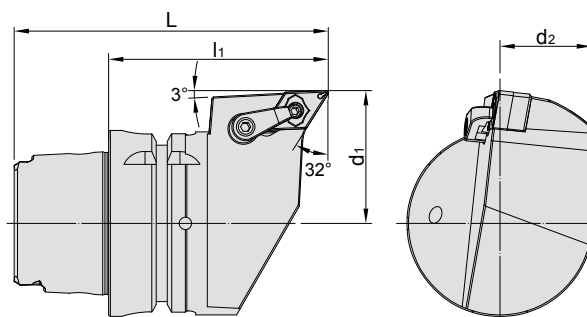

MODEL NO.	TYPE	L	l ₁	d ₁	d ₂	Insert	WEIGHT (KGS)
573T-476-15R-075	HSK-T63 - MDJNR - 45075 - 15	107	75	45	31	DN..1504	1.38
573T-476-15L-075	HSK-T63 - MDJNL - 45075 - 15	107	75	45	31	DN..1504	1.38

Product information:

► Inserts are optional accessories. Needs to be purchased additionally.

Accessory:

Insert	Clamp	Shim	Screw	Screw
				
DN..1504	MC622	SMD463	MS630	MLP46L-A



MTJN EXTERNAL TURNING TOOL

MTJN 外徑車刀

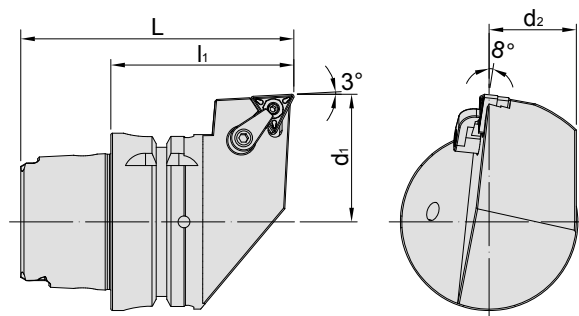

MODEL NO.	TYPE	L	l ₁	d ₁	d ₂	Insert	WEIGHT (KGS)
573T-477-16R-065	HSK-T63 - MTJNR - 45065 - 16	97	65	45	31	TN..1604	1.27
573T-477-16L-065	HSK-T63 - MTJNL - 45065 - 16	97	65	45	31	TN..1604	1.27

Product information:

► Inserts are optional accessories. Needs to be purchased additionally.

Accessory:

Insert	Clamp	Shim	Screw	Screw
TN..1604	MC620	SMT322	MS630	MLP34L-A

MWLN EXTERNAL TURNING TOOL

MWLN 外徑車刀

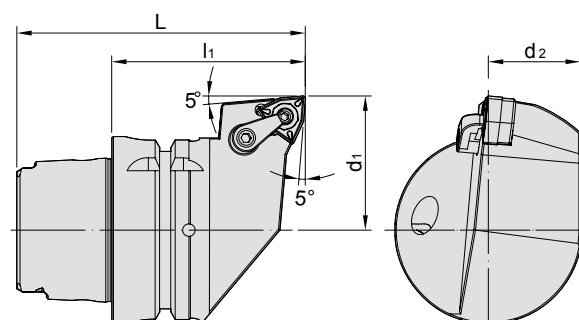

MODEL NO.	TYPE	L	l ₁	d ₁	d ₂	Insert	WEIGHT (KGS)
573T-478-08R-065	HSK-T63 - MWLNR - 45065 - 08	97	65	45	31	WN..0804	1.22
573T-478-08L-065	HSK-T63 - MWLNL - 45065 - 08	97	65	45	31	WN..0804	1.22

Product information:

► Inserts are optional accessories. Needs to be purchased additionally.

Accessory:

Insert	Clamp	Shim	Screw	Screw
WN..0804	MC620	SMW422	MS630	MLP46L-A

MVLN EXTERNAL TURNING TOOL

MVLN 外徑車刀

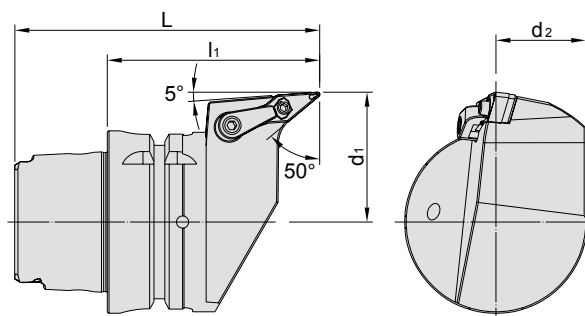

MODEL NO.	TYPE	L	l ₁	d ₁	d ₂	Insert	WEIGHT (KGS)
573T-479-16R-075	HSK-T63 - MVLNR - 45075 - 16	107	75	45	31	VN..1604	1.30
573T-479-16L-075	HSK-T63 - MVLNL - 45075 - 16	107	75	45	31	VN..1604	1.30

Product information:

► Inserts are optional accessories. Needs to be purchased additionally.

Accessory:

Insert	Clamp	Shim	Screw	Screw
VN..1604	MC622	SMV322	MS630	MLP34L-A

MCMN EXTERNAL TURNING TOOL

MCMN 外徑車刀

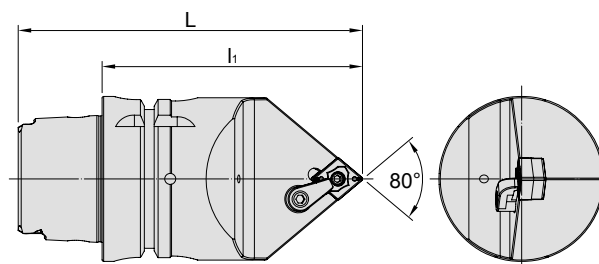

MODEL NO.	TYPE	L	l ₁	Insert	WEIGHT (KGS)
573T-480-12N-100	HSK-T63 - MCMNN - 00100 - 12	132	100	CN..1204	1.68
573T-480-12N-140	HSK-T63 - MCMNN - 00140 - 12	172	140	CN..1204	1.68

Product information:

► Inserts are optional accessories. Needs to be purchased additionally.

Accessory:

Insert	Clamp	Shim	Screw	Screw
CN..1204	MC620	SMC432	MS620	MLP46L-A



MDNN EXTERNAL TURNING TOOL

MDNN 外徑車刀

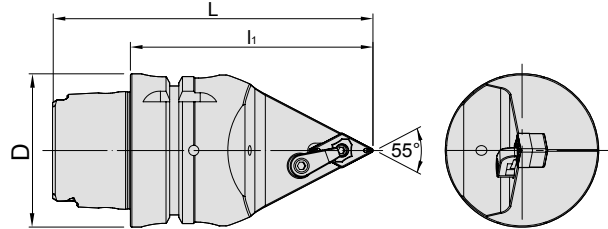

MODEL NO.	TYPE	L	l ₁	D	Insert	WEIGHT (KGS)
573T-481-15N-100	HSK-T63 - MDNNN - 00100 - 15	132	100	63	DN..1504	1.55
573T-481-15N-140	HSK-T63 - MDNNN - 00140 - 15	172	140	63	DN..1504	1.55

Product information:

► Inserts are optional accessories. Needs to be purchased additionally.

Accessory:

Insert	Clamp	Shim	Screw	Screw
DN..1504	MC622	SMD463	MS625	MLP46L-A

MTEN EXTERNAL TURNING TOOL

MTEN 外徑車刀

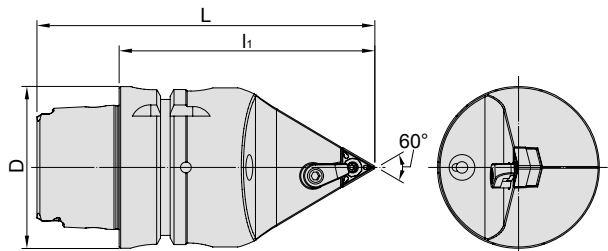

MODEL NO.	TYPE	L	l ₁	D	Insert	WEIGHT (KGS)
573T-483-16N-100	HSK-T63 - MTENN - 00100 - 16	132	100	63	TN..1604	1.62
573T-483-16N-140	HSK-T63 - MTENN - 00140 - 16	172	140	63	TN..1604	1.62

Product information:

► Inserts are optional accessories. Needs to be purchased additionally.

Accessory:

Insert	Clamp	Shim	Screw	Screw
TN..1604	MC620	SMT322	MS630	MLP34L-A



MWMN EXTERNAL TURNING TOOL

MWMN 外徑車刀

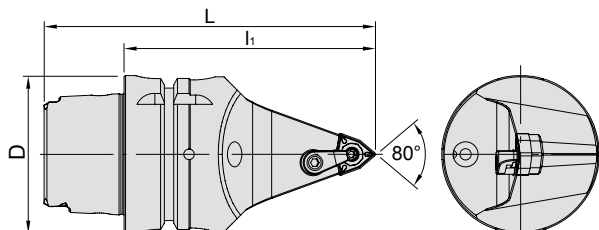

MODEL NO.	TYPE	L	l ₁	D	Insert	WEIGHT (KGS)
573T-486-08N-100	HSK-T63 - MWMNN - 00100 - 08	132	100	63	WN..0804	1.48
573T-486-08N-140	HSK-T63 - MWMNN - 00140 - 08	172	140	63	WN..0804	1.48

Product information:

► Inserts are optional accessories. Needs to be purchased additionally.

Accessory:

Insert	Clamp	Shim	Screw	Screw
WN..0804	MC620	SMW422	MS630	MLP46L-A

MVNV EXTERNAL TURNING TOOL

MVNV 外徑車刀

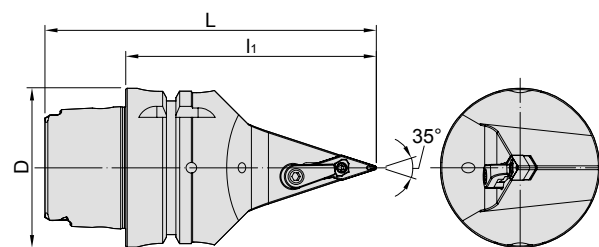

MODEL NO.	TYPE	L	l ₁	D	Insert	WEIGHT (KGS)
573T-484-16N-100	HSK-T63 - MVVNN - 00100 - 16	132	100	63	VN..1604	1.40
573T-484-16N-140	HSK-T63 - MVVNN - 00140 - 16	172	140	63	VN..1604	1.40

Product information:

► Inserts are optional accessories. Needs to be purchased additionally.

Accessory:

Insert	Clamp	Shim	Screw	Screw
VN..1604	MC622	SMV322	MS630	MLP34L-A



MCLN EXTERNAL TURNING TOOL

Ultra High Pressure-UHP type

140 bar

MCLN 外徑車刀 [超高水壓型]

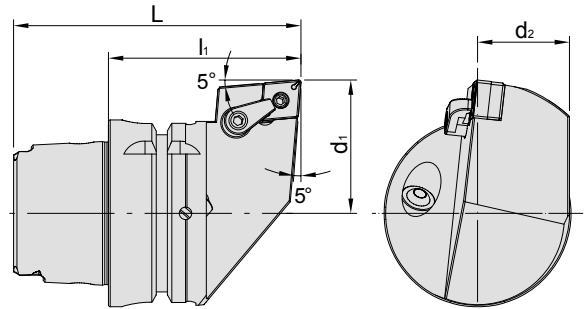

MODEL NO.	TYPE	L	l ₁	d ₁	d ₂	Insert	WEIGHT (KGS)
573T-445-12R-065	HSK-T63 - MCLNR - 45065 - 12 - UHP	97	65	45	31	CN..1204	1.26
573T-445-12L-065	HSK-T63 - MCLNL - 45065 - 12 - UHP	97	65	45	31	CN..1204	1.26

Product information:

► Inserts are optional accessories. Needs to be purchased additionally.

Accessory:

Insert	Clamp	Shim	Screw	Screw
CN..1204	MC620	SMC432	MS630	MLP46L-A

MDJN EXTERNAL TURNING TOOL

Ultra High Pressure-UHP type

140 bar

MDJN 外徑車刀 [超高水壓型]

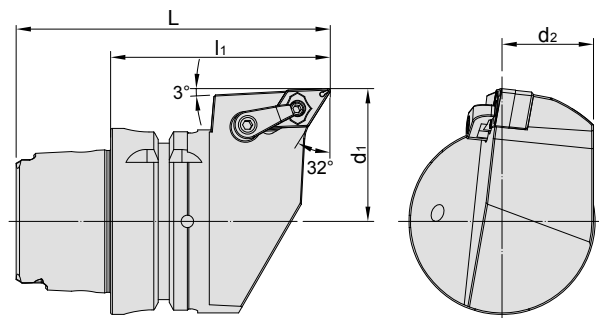

MODEL NO.	TYPE	L	l ₁	d ₁	d ₂	Insert	WEIGHT (KGS)
573T-446-15R-075	HSK-T63 - MDJNR - 45075 - 15 - UHP	107	75	45	31	DN..1504	1.38
573T-446-15L-075	HSK-T63 - MDJNL - 45075 - 15 - UHP	107	75	45	31	DN..1504	1.38

Product information:

► Inserts are optional accessories. Needs to be purchased additionally.

Accessory:

Insert	Clamp	Shim	Screw	Screw
DN..1504	MC622	SMD463	MS630	MLP46L-A

MTJN EXTERNAL TURNING TOOL

Ultra High Pressure-UHP type

140
bar

MTJN 外徑車刀 [超高水壓型]

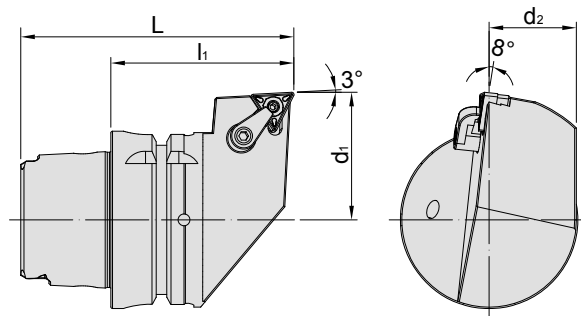

MODEL NO.	TYPE	L	l ₁	d ₁	d ₂	Insert	WEIGHT (KGS)
573T-447-16R-065	HSK-T63 - MTJNR - 45065 - 16 - UHP	97	65	45	31	TN..1604	1.27
573T-447-16L-065	HSK-T63 - MTJNL - 45065 - 16 - UHP	97	65	45	31	TN..1604	1.27

Product information:

► Inserts are optional accessories. Needs to be purchased additionally.

Accessory:

Insert	Clamp	Shim	Screw	Screw
TN..1604	MC620	SMT322	MS630	MLP34L-A

MWLN EXTERNAL TURNING TOOL

Ultra High Pressure-UHP type

140
bar

MWLN 外徑車刀 [超高水壓型]

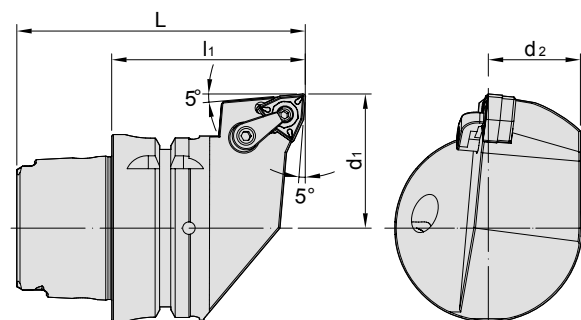

MODEL NO.	TYPE	L	l ₁	d ₁	d ₂	Insert	WEIGHT (KGS)
573T-448-08R-065	HSK-T63 - MWLNR - 45065 - 08 - UHP	97	65	45	31	WN..0804	1.22
573T-448-08L-065	HSK-T63 - MWLNL - 45065 - 08 - UHP	97	65	45	31	WN..0804	1.22

Product information:

► Inserts are optional accessories. Needs to be purchased additionally.

Accessory:

Insert	Clamp	Shim	Screw	Screw
WN..0804	MC620	SMW422	MS630	MLP46L-A



MVLN EXTERNAL TURNING TOOL

Ultra High Pressure-UHP type

140 bar

MVLN 外徑車刀 [超高水壓型]

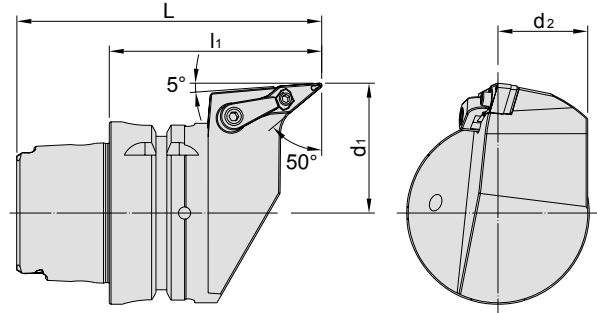

MODEL NO.	TYPE	L	l ₁	d ₁	d ₂	Insert	WEIGHT (KGS)
573T-449-16R-075	HSK-T63 - MVLNR - 45075 - 16 - UHP	107	75	45	31	VN..1604	1.30
573T-449-16L-075	HSK-T63 - MVLNL - 45075 - 16 - UHP	107	75	45	31	VN..1604	1.30

Product information:

► Inserts are optional accessories. Needs to be purchased additionally.

Accessory:

Insert	Clamp	Shim	Screw	Screw
VN..1604	MC622	SMV322	MS630	MLP34L-A

MCMN EXTERNAL TURNING TOOL

Ultra High Pressure-UHP type

140 bar

MCMN 外徑車刀 [超高水壓型]

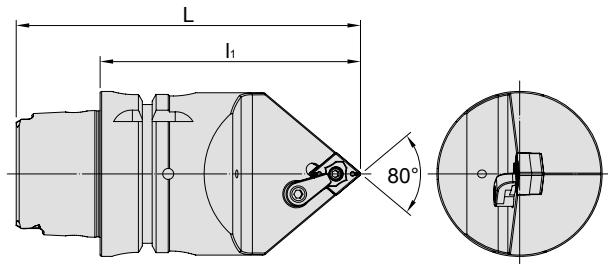

MODEL NO.	TYPE	L	l ₁	Insert	WEIGHT (KGS)
573T-450-12N-100	HSK-T63 - MCMNN - 00100 - 12 - UHP	132	100	CN..1204	1.68
573T-450-12N-140	HSK-T63 - MCMNN - 00140 - 12 - UHP	172	140	CN..1204	1.68

Product information:

► Inserts are optional accessories. Needs to be purchased additionally.

Accessory:

Insert	Clamp	Shim	Screw	Screw
CN..1204	MC620	SMC432	MS620	MLP46L-A

MDNN EXTERNAL TURNING TOOL

Ultra High Pressure-UHP type

140
bar

MDNN 外徑車刀 [超高水壓型]

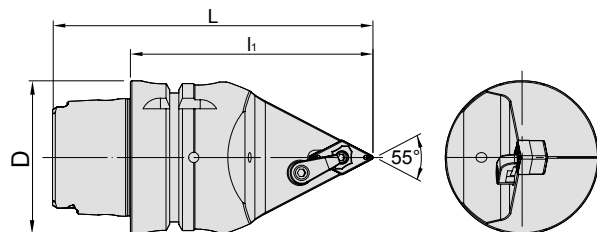

MODEL NO.	TYPE	L	l ₁	D	Insert	WEIGHT (KGS)
573T-451-15N-100	HSK-T63 - MDNNN - 00100 - 15 - UHP	132	100	63	DN..1504	1.55
573T-451-15N-140	HSK-T63 - MDNNN - 00140 - 15 - UHP	172	140	63	DN..1504	1.55

Product information:

► Inserts are optional accessories. Needs to be purchased additionally.

Accessory:

Insert	Clamp	Shim	Screw	Screw
				
DN..1504	MC622	SMD463	MS625	MLP46L-A

MTEN EXTERNAL TURNING TOOL

Ultra High Pressure-UHP type

140
bar

MTEN 外徑車刀 [超高水壓型]

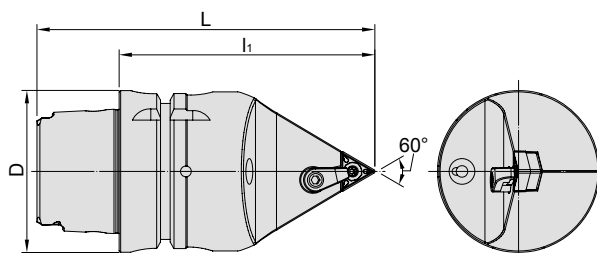

MODEL NO.	TYPE	L	l ₁	D	Insert	WEIGHT (KGS)
573T-452-16N-100	HSK-T63 - MTENN - 00100 - 16 - UHP	132	100	63	TN..1604	1.62
573T-452-16N-140	HSK-T63 - MTENN - 00140 - 16 - UHP	172	140	63	TN..1604	1.62

Product information:

► Inserts are optional accessories. Needs to be purchased additionally.

Accessory:

Insert	Clamp	Shim	Screw	Screw
				
TN..1604	MC620	SMT322	MS630	MLP34L-A



MWMN EXTERNAL TURNING TOOL

Ultra High Pressure-UHP type

140 bar

MWMN 外徑車刀 [超高水壓型]

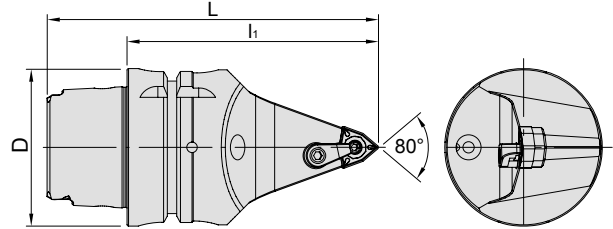

MODEL NO.	TYPE	L	l ₁	D	Insert	WEIGHT (KGS)
573T-453-08N-100	HSK-T63 - MWMN - 00100 - 08 - UHP	132	100	63	WN..0804	1.48
573T-453-08N-140	HSK-T63 - MWMN - 00140 - 08 - UHP	172	140	63	WN..0804	1.48

Product information:

▶ Inserts are optional accessories. Needs to be purchased additionally.

Accessory:

Insert	Clamp	Shim	Screw	Screw
WN..0804	MC620	SMW422	MS630	MLP46L-A

MVNN EXTERNAL TURNING TOOL

Ultra High Pressure-UHP type

140 bar

MVNN 外徑車刀 [超高水壓型]

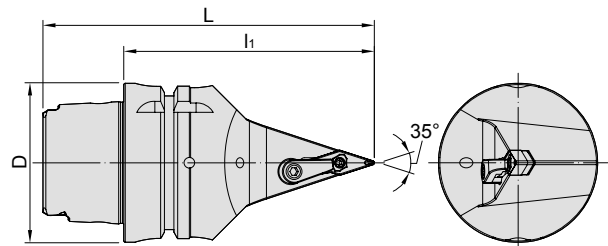

MODEL NO.	TYPE	L	l ₁	D	Insert	WEIGHT (KGS)
573T-454-16N -100	HSK-T63 - MVNN - 00100 - 16 - UHP	132	100	63	VN..1604	1.40
573T-454-16N-140	HSK-T63 - MVNN - 00140 - 16 - UHP	172	140	63	VN..1604	1.40

Product information:

▶ Inserts are optional accessories. Needs to be purchased additionally.

Accessory:

Insert	Clamp	Shim	Screw	Screw
VN..1604	MC622	SMV322	MS630	MLP34L-A

DE EXTERNAL THREADING TOOL

ULTRA HIGH PRESSURE-UHP TYPE

HSK - T

140
bar

DE 外徑螺紋牙刀

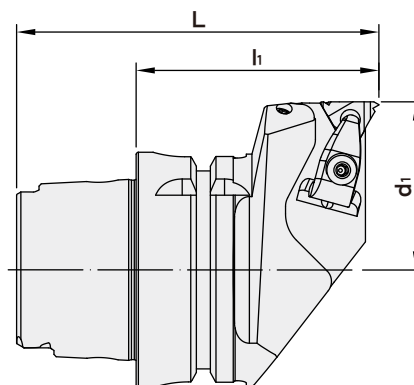

MODEL NO.	TYPE	L	l ₁	d ₁	Insert	WEIGHT (KGS)
573T-096-16R-065	HSK-T63-DER-45065-16-UHP	97	65	45	16ER..	1.23
573T-096-16L-065	HSK-T63-DEL-45065-16-UHP	97	65	45	16NR..	1.23

Product information:

► Inserts are optional accessories. Need to be purchased additionally.

Accessory:

Insert	Clamp	Lever screw	Shim	Shim screw	Spring	Wrench
 16ER../16NR..	 CHD16	 L85020-T15P	 GX16-1	 CS3507-T09P	 S6912	 T15P-7



SIDE LOCK HOLDER

FOR INTERNAL TURNING BAR

SLT 側固式刀桿 [用於內徑車刀]

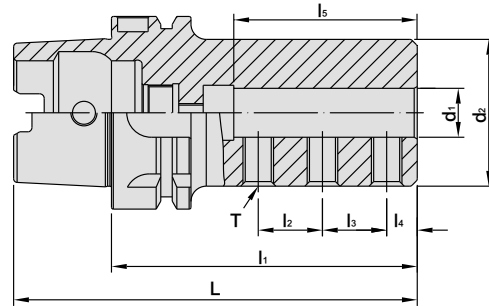

MODEL NO.	TYPE	L	l ₁	l ₂	l ₃	l ₄	l ₅	d ₁	d ₂	T	WEIGHT (KGS)
573T-797-008-070	HSK-T63 x SLT8 - 70	102	70	10	10	6	32	8	28	M6	0.93
573T-797-010-080	HSK-T63 x SLT10 - 80	112	80	12	12	8	40	10	35	M8	1.10
573T-797-012-090	HSK-T63 x SLT12 - 90	122	90	16	16	8	45	12	42	M8	1.36
573T-797-016-100	HSK-T63 x SLT16 - 100	132	100	21	21	10	60	16	48	M10	1.60
573T-797-020-120	HSK-T63 x SLT20 - 120	152	120	20	20	12	60	20	52	M10	2.03
573T-797-025-140	HSK-T63 x SLT25 - 140	172	140	23	23	14	67	25	56	M12	2.52
573T-797-032-160	HSK-T63 x SLT32 - 160	192	160	26	26	16	74	32	64	M12	3.34

► Use screws to change the coolant outlet from tool coolant hole or from tool holder.

	MODEL NO.	TYPE
<p>SCREW FOR COOLANT OUTLET FROM TOOL</p>	B06 - 01M4 x 0.7P - 503	SLT8
	B06 - 01M5 x 0.8P - 503	SLT10
	B06 - 01M6 x 1.0P - 603	SLT12, SLT16, SLT20
	B06 - 01M8 x 1.25P - 603	SLT25, SLT32
<p>SCREW FOR COOLANT OUTLET FROM TOOL HOLDER</p>	B05 - 03M6 x 1.0P - 803	M6 x 1.0P - 8L EBSS6-8

Product information:

- Both screws are standard accessories.



SIDE LOCK HOLDER

FOR HIGH SPEED DRILL

SLD 側固式刀桿 [用於快鑽]

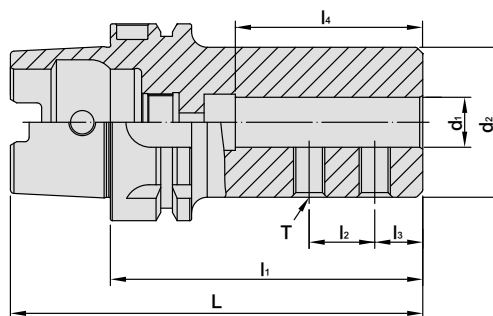
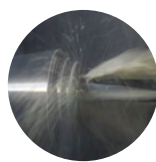

MODEL NO.	TYPE	L	l ₁	l ₂	l ₃	l ₄	d ₁	d ₂	T	WEIGHT (KGS)
573T-798-008-065	HSK-T63 x SLD8 - 65	97	65	18	10	34	8	28	M8	0.84
573T-798-010-070	HSK-T63 x SLD10 - 70	102	70	20	12	39	10	35	M8	0.97
573T-798-012-070	HSK-T63 x SLD12 - 70	102	70	20	12	39	12	42	M8	1.10
573T-798-016-075	HSK-T63 x SLD16 - 75	107	75	20	15	44	16	48	M10	1.26
573T-798-020-075	HSK-T63 x SLD20 - 75	107	75	20	15	44	20	52	M10	1.34
573T-798-025-085	HSK-T63 x SLD25 - 85	117	85	23	17	52	25	62	M12	1.79
573T-798-032-090	HSK-T63 x SLD32 - 90	122	90	27	17	56	32	62	M12	1.74
573T-798-040-100	HSK-T63 x SLD40 - 100	132	100	28	22	62	40	68	M16	2.00

EXTERNAL TURNING TOOL HOLDER

外徑車刀架 [軸向]

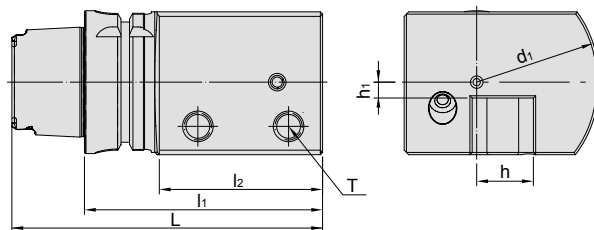

MODEL NO.	TYPE	L	l ₁	l ₂	d ₁	h	h ₁	T	WEIGHT (KGS)
573T-776-25R-105	HSK-T63 x S25R - 105	137	105	70	54	25	6	M12 x 1.75P	3.40
573T-776-25L-105	HSK-T63 x S25L - 105	137	105	70	54	25	6	M12 x 1.75P	3.40



EXTERNAL TURNING TOOL HOLDER

SV 外徑車刀架 [軸向]

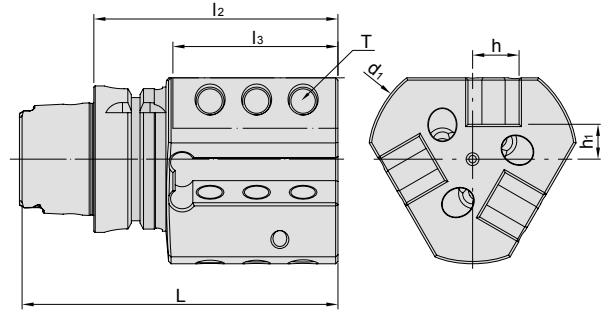

MODEL NO.	TYPE	L	l ₂	l ₃	d ₁	h	h ₁	T	WEIGHT (KGS)
573T-S47-20R-105	HSK-T63 x SV20R - 105	137	105	70	90	20	15	M12 x 1.75P	2.72
573T-S47-20L-105	HSK-T63 x SV20L - 105	137	105	70	90	20	15	M12 x 1.75P	2.72

EXTERNAL TURNING TOOL HOLDER

SB 外徑車刀架 [軸向]

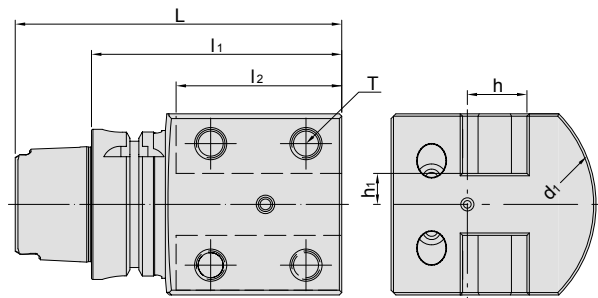

MODEL NO.	TYPE	L	l ₁	l ₂	h	h ₁	d ₁	T	WEIGHT (KGS)
573T-S45-25R-105	HSK-T63 x SB25R - 105	137	105	70	25	13	54	M12 x 1.75P	2.98

EXTERNAL TURNING TOOL HOLDER

SF 外徑車刀架 [徑向]

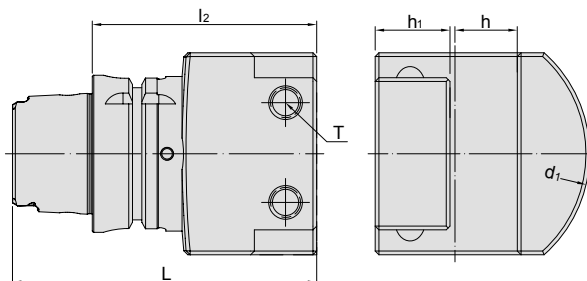

MODEL NO.	TYPE	L	l ₂	h	h ₁	d ₁	T	WEIGHT (KGS)
573T-S46-025-090	HSK-T63 x SF25 - 90	122	90	25	30	54	M12 x 1.75P	3.05
573T-S46-025-120	HSK-T63 x SF25 - 120	152	120	25	30	54	M12 x 1.75P	3.99
575T-S46-032-090	HSK-T100 x SF32 - 90	140	90	32	28	142	M12 x 1.75P	4.90

EXTERNAL TURNING TOOL HOLDER

SN 外徑車刀架

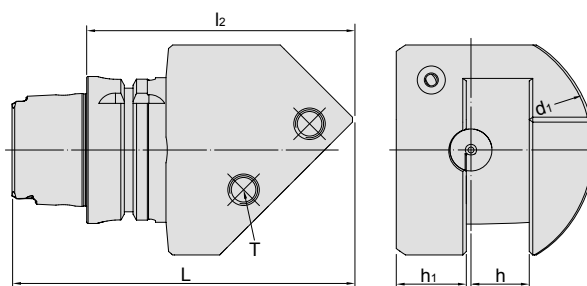

MODEL NO.	TYPE	L	l ₂	d ₁	h	h ₁	T	WEIGHT (KGS)
573T-766-25R-115	HSK-T63 x SN25R - 115	147	115	53	25	30	M12 x 1.75P	3.40
573T-766-25L-115	HSK-T63 x SN25L - 115	147	115	53	25	30	M12 x 1.75P	3.40



HSK BLANK

HSK 素材

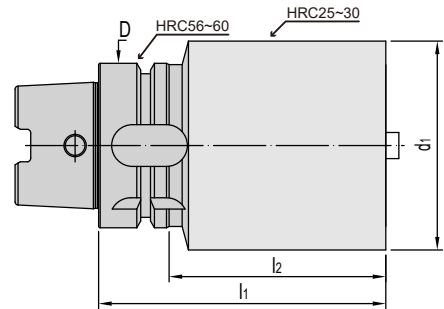

MODEL NO.	TYPE	D	d ₁	l ₁	l ₂	WEIGHT (KGS)
573T-001-062-150	HSK-T63 x Ø62 - 150	63	62	150	124	3.51
573T-001-062-200	HSK-T63 x Ø62 - 200	63	62	200	174	4.67
573T-001-062-250	HSK-T63 x Ø62 - 250	63	62	250	224	5.84
573T-001-063-100	HSK-T63 x Ø63 - 100	63	63	100	74	2.44
573T-001-063-140	HSK-T63 x Ø63 - 140	63	63	140	114	3.42
573T-001-080-150	HSK-T63 x Ø80 - 150	63	80	150	124	5.18
573T-001-080-200	HSK-T63 x Ø80 - 200	63	80	200	174	7.12
573T-001-080-250	HSK-T63 x Ø80 - 250	63	80	250	224	9.05
573T-001-090-065	HSK-T63 x Ø90 - 65	63	90	65	39	2.48
573T-001-090-075	HSK-T63 x Ø90 - 75	63	90	75	49	2.98

Features:

- ▶ Blanks can be machined according to customer demands. It is not recommended to do heat treatment after machining.

MEMO

Blank lined area for writing.



MEMO

Blank lined area for writing a memo.

