

BMT CATEGORY

BMT STATIC TOOL HOLDER

K-2

BMT STATIC TOOL HOLDER

BMT 固定型雙頭刀座

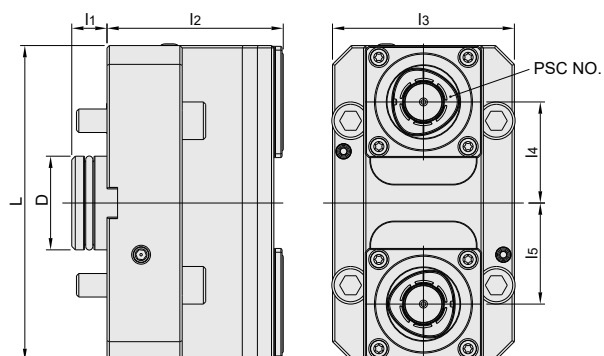

MODEL NO.	TYPE	PSC NO.	D	L	l ₁	l ₂	l ₃	l ₄	l ₅	RIGHT/LEFT HAND	WEIGHT (KGS)
5370-S3R-021-01	BMT40-PSC40-0°-DR	PSC40	40	134	15	75	77.4	43	43	R	4.43
5370-S3L-021-01	BMT40-PSC40-0°-DL	PSC40	40	134	15	75	77.4	43	43	L	4.43



Features:

- ▶ The jaw clamping design allows quick tool change and tool can be measured offline in advance, reducing downtime and improving processing efficiency.
- ▶ Applicable machine type: Turn-mill multitasking machine. Applicable industry: Automation, electronics and spare parts industries.
- ▶ Clamping force is inspected individually before delivery.
- ▶ Built-in with center coolant mechanism, and coolant pressure can be up to 70BAR.
- ▶ Used with the PSC taper tools, which have the features of bending strength, and superior repeat positioning accuracy.
- ▶ Suitable for turning and center hole drilling and tapping.

MEMO

Blank memo area consisting of 20 horizontal grey lines for writing.



MEMO

Blank memo area consisting of 18 horizontal grey bars for writing.

