

PSC WORKPIECE QUICK CHANGE SYSTEM CATEGORY

PSC HYDRAULIC TYPE WORKPIECE QUICK CHANGE SYSTEM

U-2

PSC MANUAL TYPE WORKPIECE QUICK CHANGE SYSTEM

U-3

PSC HYDRAULIC TYPE WORKPIECE QUICK CHANGE SYSTEM

PSC 油壓式工件快換系統

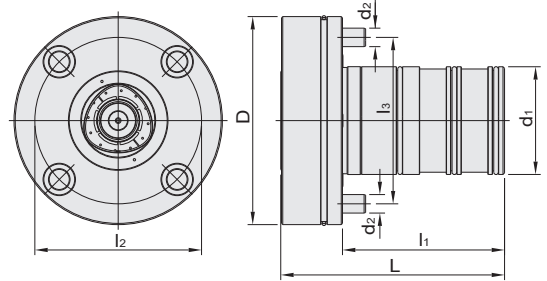

MODEL NO.	TYPE	L	l ₁	l ₂	l ₃	D	d ₁	d ₂	WEIGHT (KGS)
5306-206-00	PSC63	145	105	108	108	135	70	12	5.66

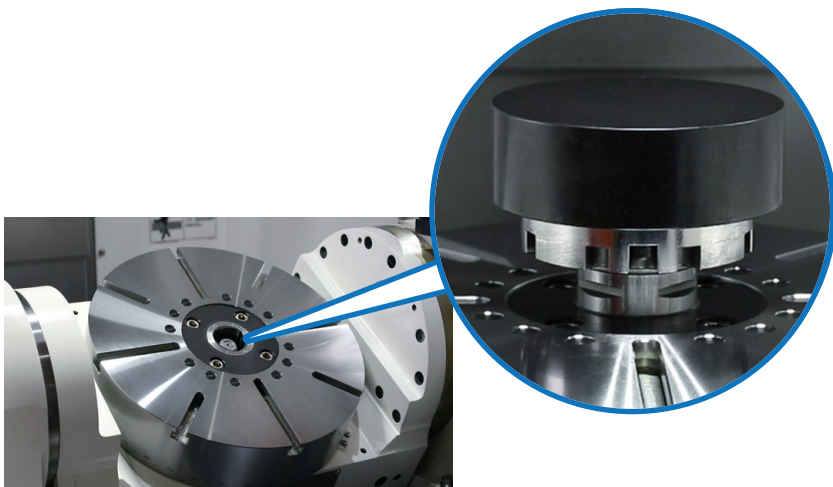

Features:

- ▶ Quick positioning and workpiece clamping save the downtime for manual feeding.
- ▶ Workpiece can be clamped offline to decrease setting time in the machine and increase production efficiency.
- ▶ PSC triple-face contact structure has the best bending strength and superior repeat positioning accuracy(±2μm).
- ▶ Clamping force is inspected individually before delivery.



PSC MANUAL TYPE WORKPIECE QUICK CHANGE SYSTEM

PSC 手動式工件快換系統

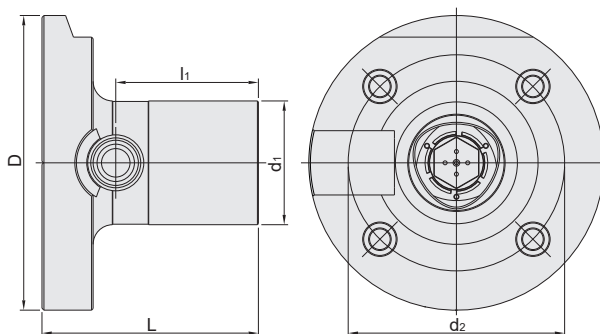

MODEL NO.	TYPE	L	l ₁	D	d ₁	d ₂	WEIGHT (KGS)
5306-046-01	PSC63 - C	110	72.5	150	63	110	4.62

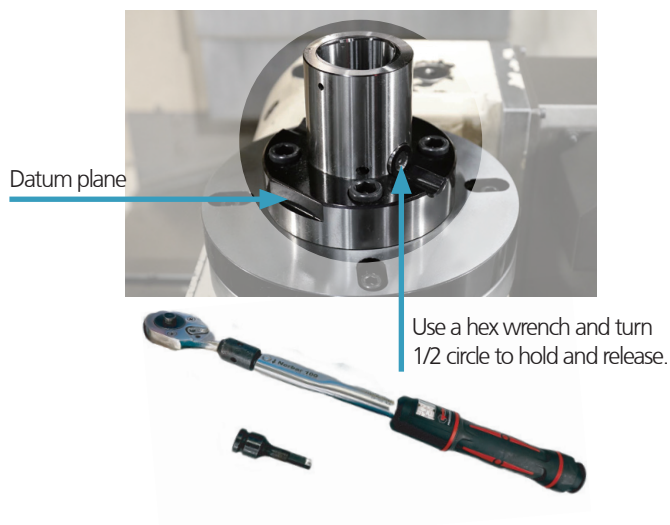

Features:

- ▶ Quick positioning and workpiece clamping save the downtime for manual feeding.
- ▶ Workpiece can be clamped offline to decrease setting time in the machine and increase production efficiency.
- ▶ PSC triple-face contact structure has the best bending strength and superior repeat positioning accuracy(±2μm).
- ▶ Clamping force is inspected individually before delivery.



MEMO

Blank lined area for writing a memo.

