

# ATC ALIGNMENT TOOL SET



## Guardian of Machine Accuracy

Used for checking ATC positioning accuracy between ATC arm and machine spindle, and between ATC arm and tool magazine.

- ▶ Prevent tool holder tapers from abnormal wear.
- ▶ Detect the potential problems of machines and decrease the probability of machine breakdown.
- ▶ Prolong the use life of machine spindle.



### SBT

MAS 403  
DualDRIVE+



### SCAT

ANSI B5.50  
DualDRIVE+



### SDAT

DIN 69871-A  
DualDRIVE+



### HSK

DIN 69893  
A, E, F Type



### PSC

ISO 26623-1



心源工業股份有限公司  
SHIN-YAIN INDUSTRIAL CO., LTD.

43644 台中市清水區菁埔路198號  
NO.198, Jingpu Rd., Qingshui Dist,  
Taichung City 436, Taiwan

Tel: +886-4-26237575  
Fax: +886-4-26237676  
E-mail: sales@syic.com







# INSTRUCTIONS FOR USE (SBT/SCAT/SDAT SERIES)

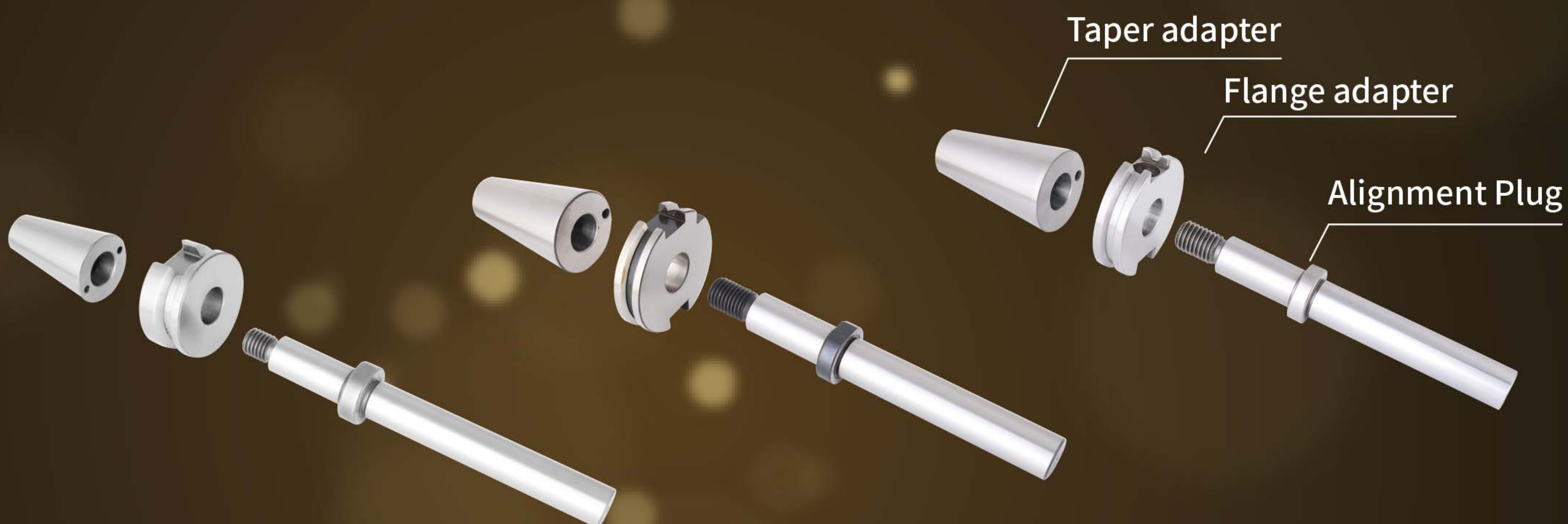

01

Clean machine spindle by spindle wiper.

1



02

Assemble the taper adapter with pull stud and screw, insert taper adapter into spindle manually with screw and push machine controller button to clamp taper adapter, then loosen the screw.

2

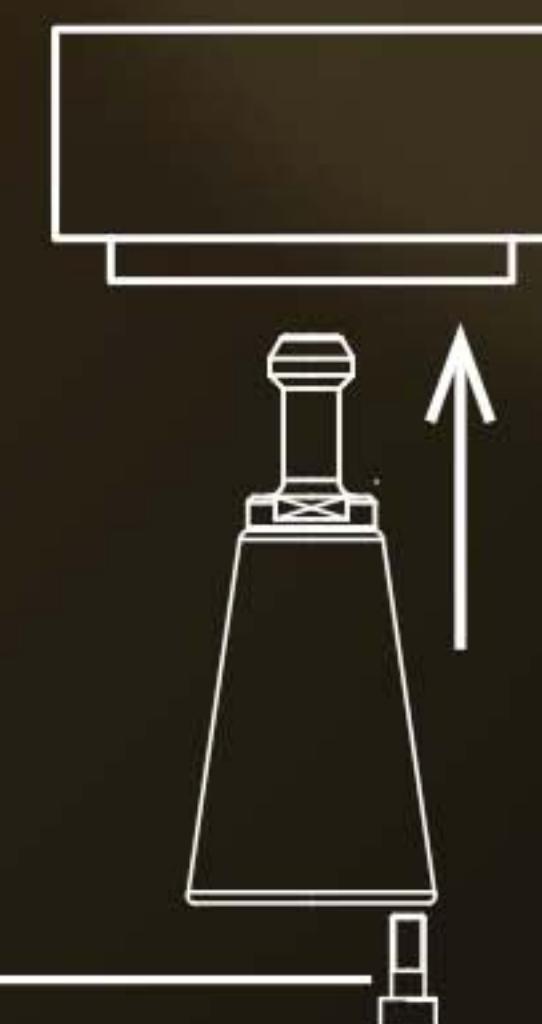

M4x0.7P (#30)  
M6x1.0P (#40 & #50)

03

Install the flange adapter into gripper of ATC arm and press machine controller button to move ATC arm to align with machine spindle.

3

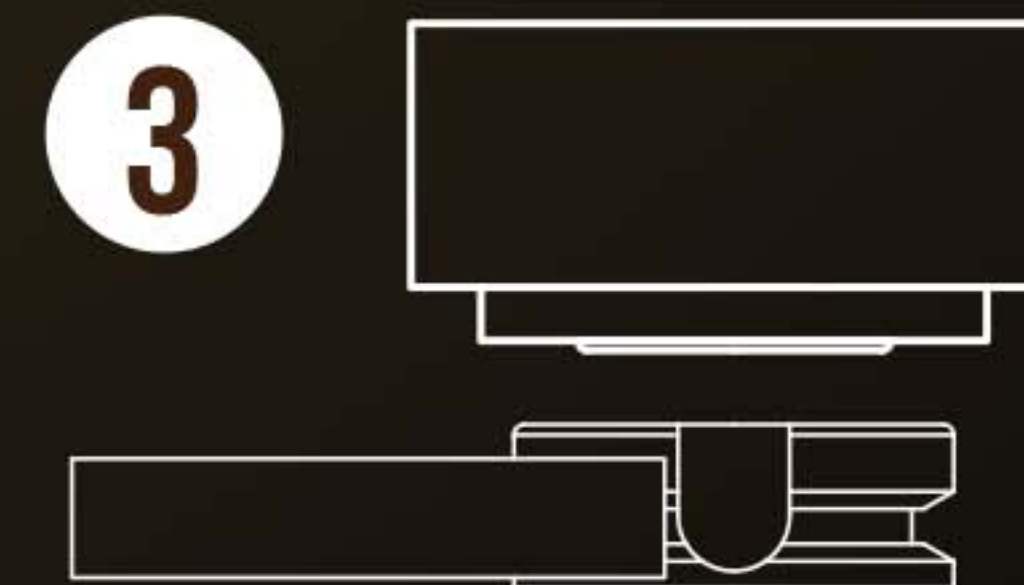

04

Insert alignment plug into the holes of flange adapter and taper adapter for alignment. If alignment plug can be inserted with ease and the movement is smooth, the alignment is done. If alignment plug can't be inserted into the holes of flange adapter and taper adapter, or it is hard to be inserted, please contact your machine supplier to inspect and adjust the positioning accuracy of ATC arm.

4

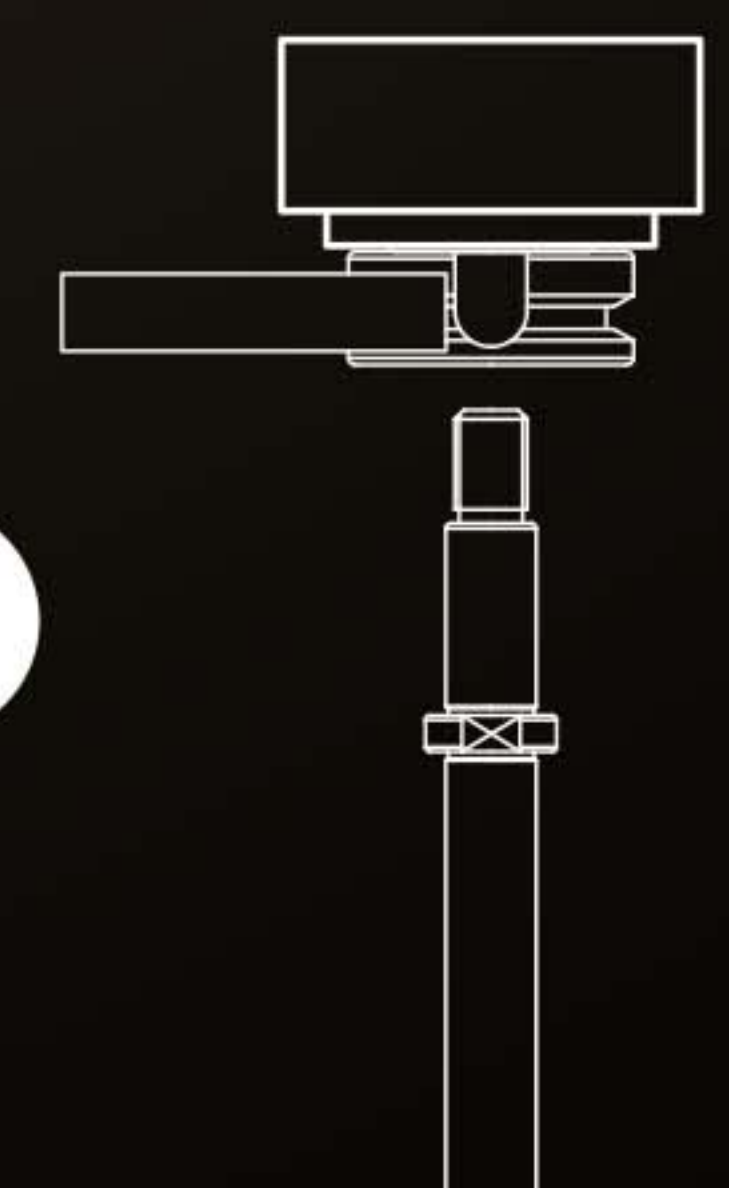

05

After completing alignment, unload alignment plug and flange adapter. Hold the taper adapter manually with screw and release it from spindle by pressing release button.

5

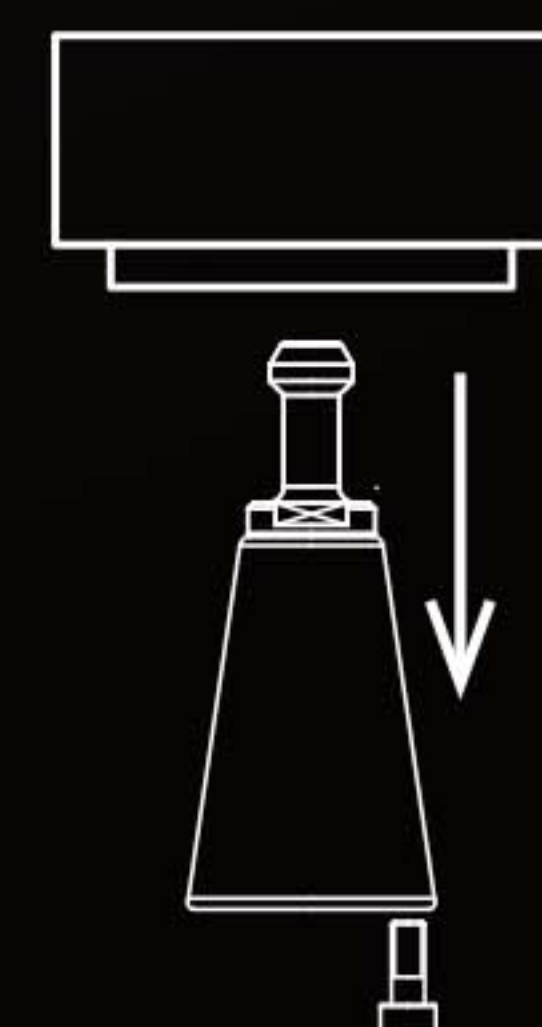





# INSTRUCTIONS FOR USE

## (PSC & HSK SERIES)

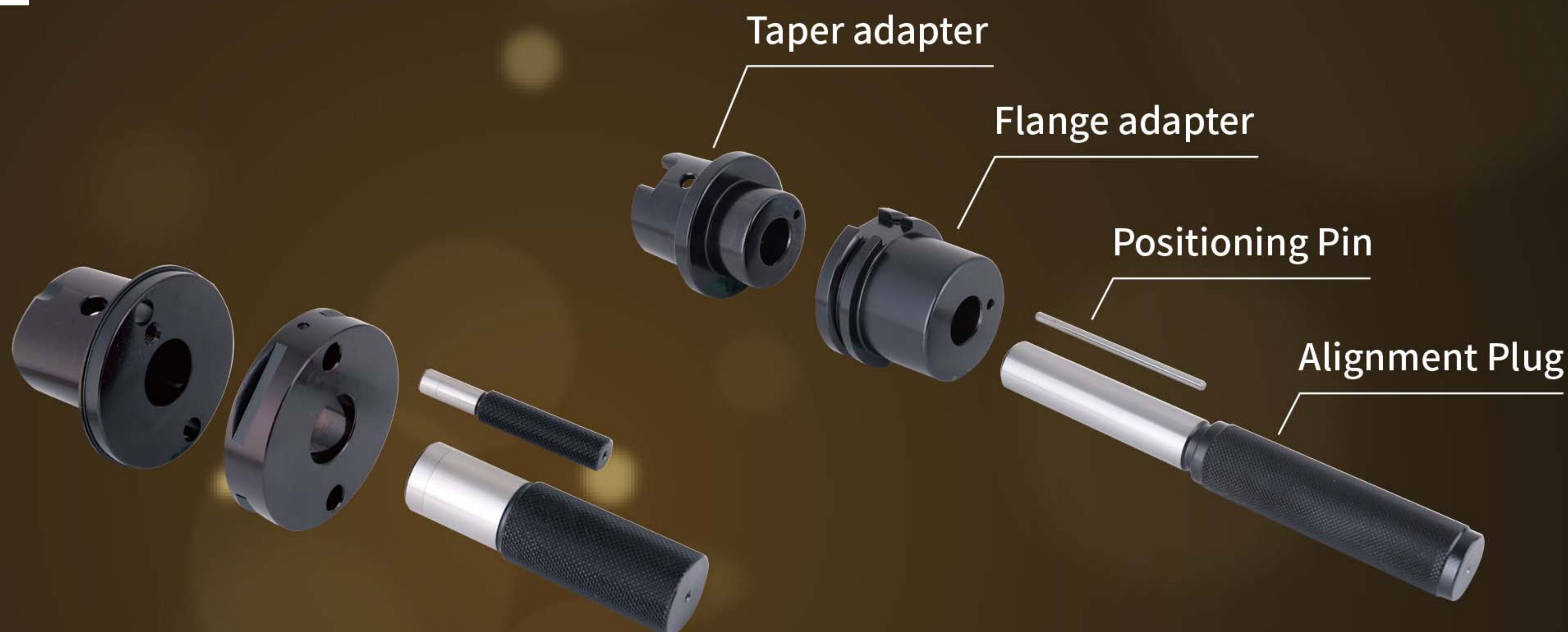

01

Clean machine spindle by spindle wiper.

1



02

Insert the taper adapter into spindle manually and push machine controller button to clamp the taper adapter.

2



03

Install the flange adapter into gripper of ATC arm and press machine controller button to move ATC closer to machine spindle. Use positioning pin to adjust flange adapter to align position hole with taper adapter and spindle.

3

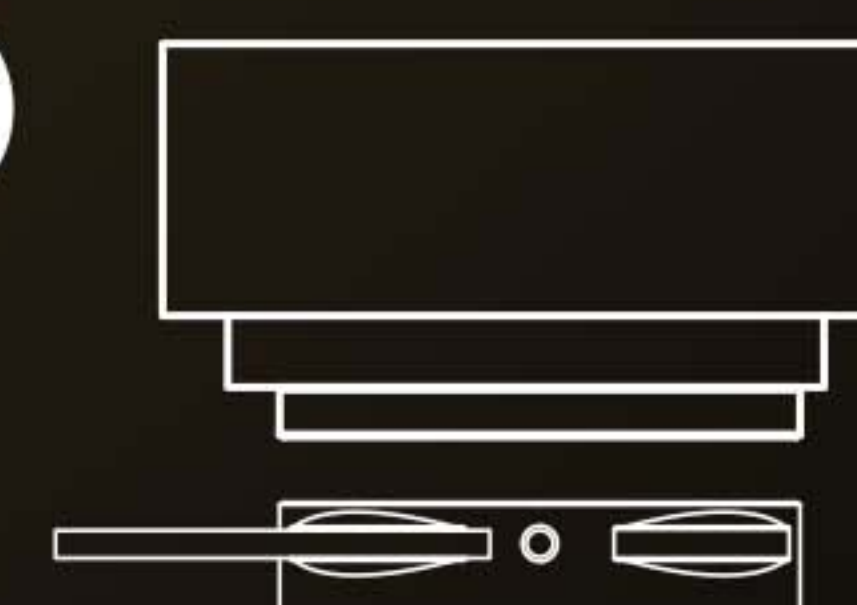

04

Insert alignment plug and positioning pin into the holes of flange adapter and taper adapter for alignment. If alignment plug and positioning pin can be inserted with ease and the movement is smooth, the alignment is done. If alignment plug and positioning pin can't be inserted into the holes of flange adapter and taper adapter, or it is hard to be inserted, please contact your machine supplier to inspect and adjust the positioning accuracy of ATC arm.

4

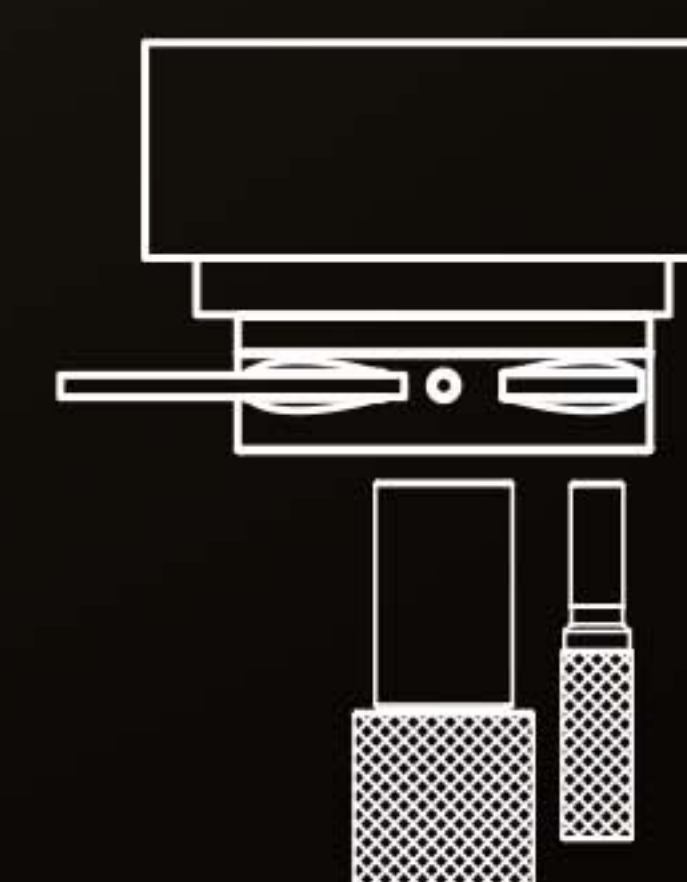

05

After completing alignment, unload alignment plug, positioning pin and flange adapter. Hold the taper adapter by hand and remove it from spindle by pressing releasing button.

5

