

FMH-SDG 寂靜抑震面銑刀桿

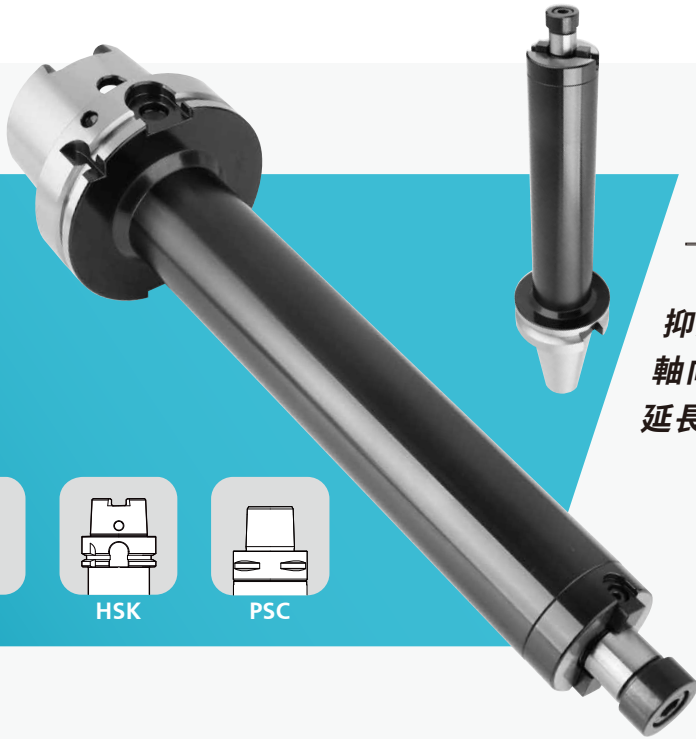

SDG *KPZ*
SILENT DAMPING GENIUS

抑震面銑刀桿內藏動態減震器，可有效吸收徑向與軸向的切削震動，改善工件的表面精度，延長刀具壽命，維持主軸精度，提升總體生產效率。

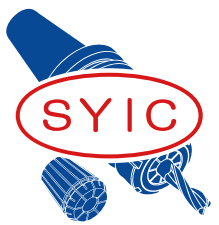

SBT



HSK



PSC

殼型銑刀頭



KPMC 45°
殼型銑刀



SFMC 45°
殼型銑刀

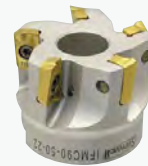

IFMC
直角殼型銑刀

▶ 銑刀頭帶有出水孔設計



▶ 給水槽螺絲

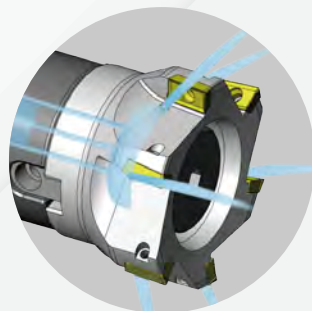

心源工業股份有限公司
SHIN-YAIN INDUSTRIAL CO., LTD.

436406 台中市清水區菁埔路198號
NO.198, Jingpu Rd., Qingshui Dist,
Taichung City 436406, Taiwan

Tel: +886-4-26237575
Fax: +886-4-26237676
E-mail: sales@syic.com



www.syic.com