

SAH ANGLE HEAD HOLDER FOR DRILLING & TAPPING

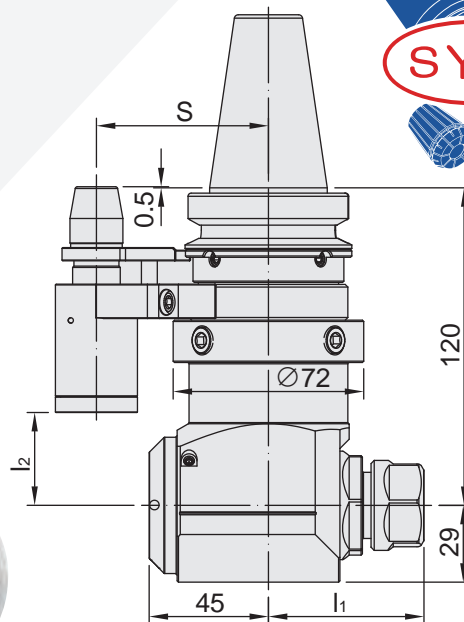

**Japanese-made
Bearing**
Precision: P4



Ground Gear
JIS B1704 : 1978 : Class 2



Circular runout: $\leq 20\mu\text{m}$
Angularity: $\pm 8\mu\text{m}$

- ▶ Max. revolution: 4,000rpm.
- ▶ Max. torque: 15N-m.
- ▶ Internal coolant not available.
- ▶ Workable for ATC system.

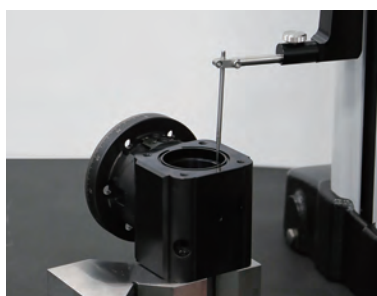

Measuring precision



Roundness: $2\mu\text{m}$



Taper tolerance: $<AT3$

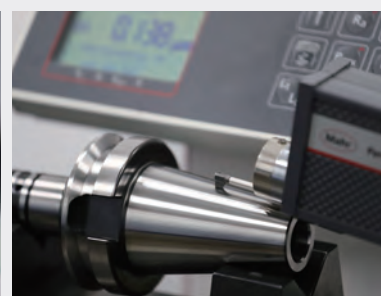

**Surface roughness:
 $Ra < 0.25\mu\text{m}$**

SJANK	MODEL NO.	TYPE	L	l ₁	l ₂	S	TORQUE	COLLET	TOOL SHANK SIZE	WEIGHT (KGS)
 MAS 403	5011-631-201-120	BT40 x SAH20E - 120	120	58	35	65	15N-m	ER20	3mm ~13mm	4.5



心源工業股份有限公司
SHIN-YAIN INDUSTRIAL CO., LTD.

43644 台中市清水區菁埔路198號
NO.198, Jingpu Rd., Qingshui Dist,
Taichung City 436, Taiwan

Tel: +886-4-26237575
Fax: +886-4-26237676
E-mail: sales@syic.com



www.syic.com