

# SAH ANGLE HEAD HOLDER FOR DRILLING & TAPPING

SAH迷你炮角度頭 適用鑽孔、攻牙

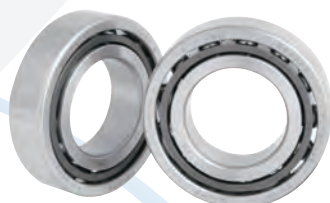

日製軸承  
精度: P4

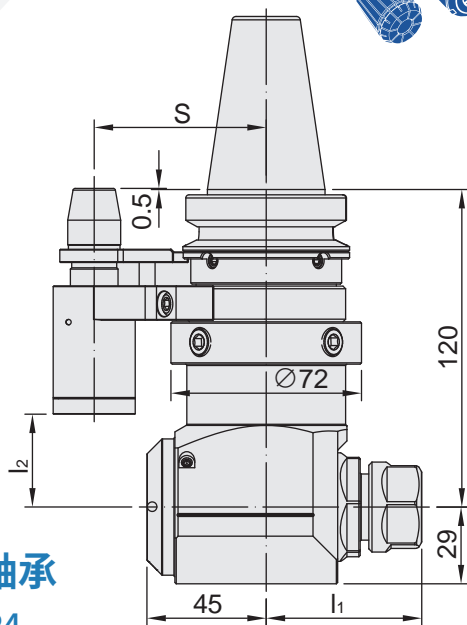

齒輪  
JIS B1704 : 1978 : 2級

- ▶ 最高轉速: 4,000rpm
- ▶ 最大扭力值: 15N-m
- ▶ 無法中心出水, 需外部給水冷卻
- ▶ 所有角度頭系列皆適用ATC自動換刀系統



偏擺度:  $\leq 20\mu\text{m}$   
傾斜度:  $\pm 8\mu\text{m}$

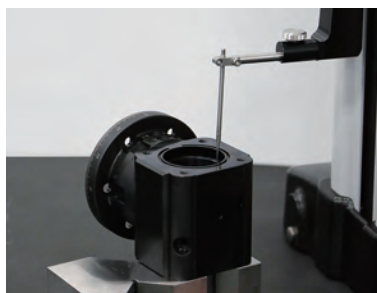

量測精度



真圓度:  $2\mu\text{m}$



錐度公差:  $<AT3$

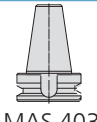

表面粗糙度:  $Ra < 0.25\mu\text{m}$

| 機械主軸  | 型號               | 規格                  | L   | l <sub>1</sub> | l <sub>2</sub> | S  | 最大扭力  | 心軸   | 鑽頭/螺絲攻<br>夾持尺寸 | 重量<br>(KGS) |
|---|------------------|---------------------|-----|----------------|----------------|----|-------|------|----------------|-------------|
| <br>MAS 403 | 5011-631-201-120 | BT40 x SAH20E - 120 | 120 | 58             | 35             | 65 | 15N-m | ER20 | 3mm<br>~13mm   | 4.5         |



心源工業股份有限公司  
SHIN-YAIN INDUSTRIAL CO., LTD.

43644 台中市清水區菁埔路198號  
NO.198, Jingpu Rd., Qingshui Dist,  
Taichung City 436, Taiwan

Tel: +886-4-26237575  
Fax: +886-4-26237676  
E-mail: sales@syic.com

