

SFS 系列

SFS後拉式刀桿 & SFS/MFS熱膨脹延長桿



高精度

適用五軸加工

高轉速
G2.5 25000rpm



- ▶ 後拉式模組化設計，節省採購成本。
- ▶ 可搭配使用兩種不同材質的熱膨脹延長桿：
 - SFS熱膨脹延長桿：材質為熱作模具鋼。
 - MFS熱膨脹延長桿：材質為耐熱鋼。
- ▶ 熱膨脹延長桿提供S型及R型供選擇。

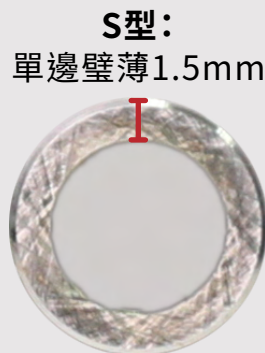

避免加工干涉

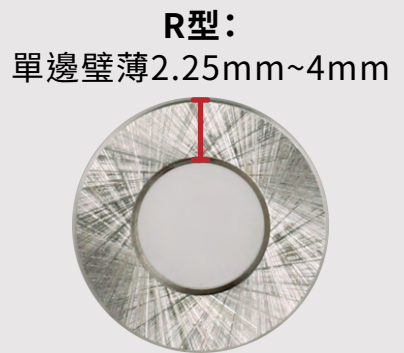

剛性佳

- ▶ 適用於五軸加工機。

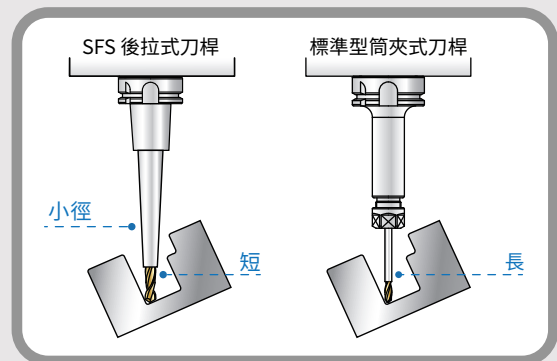

- ▶ 適用出水型刀具作中心出水。



BT30/SBT30xSFS後拉式刀桿搭配使用的拉頭與後拉螺絲為一體式設計，若有需要訂製拉頭，請聯繫銷售人員。



心源工業股份有限公司
SHIN-YAIN INDUSTRIAL CO., LTD.

436406 台中市清水區菁埔路198號
NO.198, Jingpu Rd., Qingshui Dist,
Taichung City 436406, Taiwan

Tel: +886-4-26237575
Fax: +886-4-26237676
E-mail: sales@syic.com



www.syic.com