

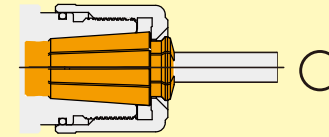

SK3 SYSTEM

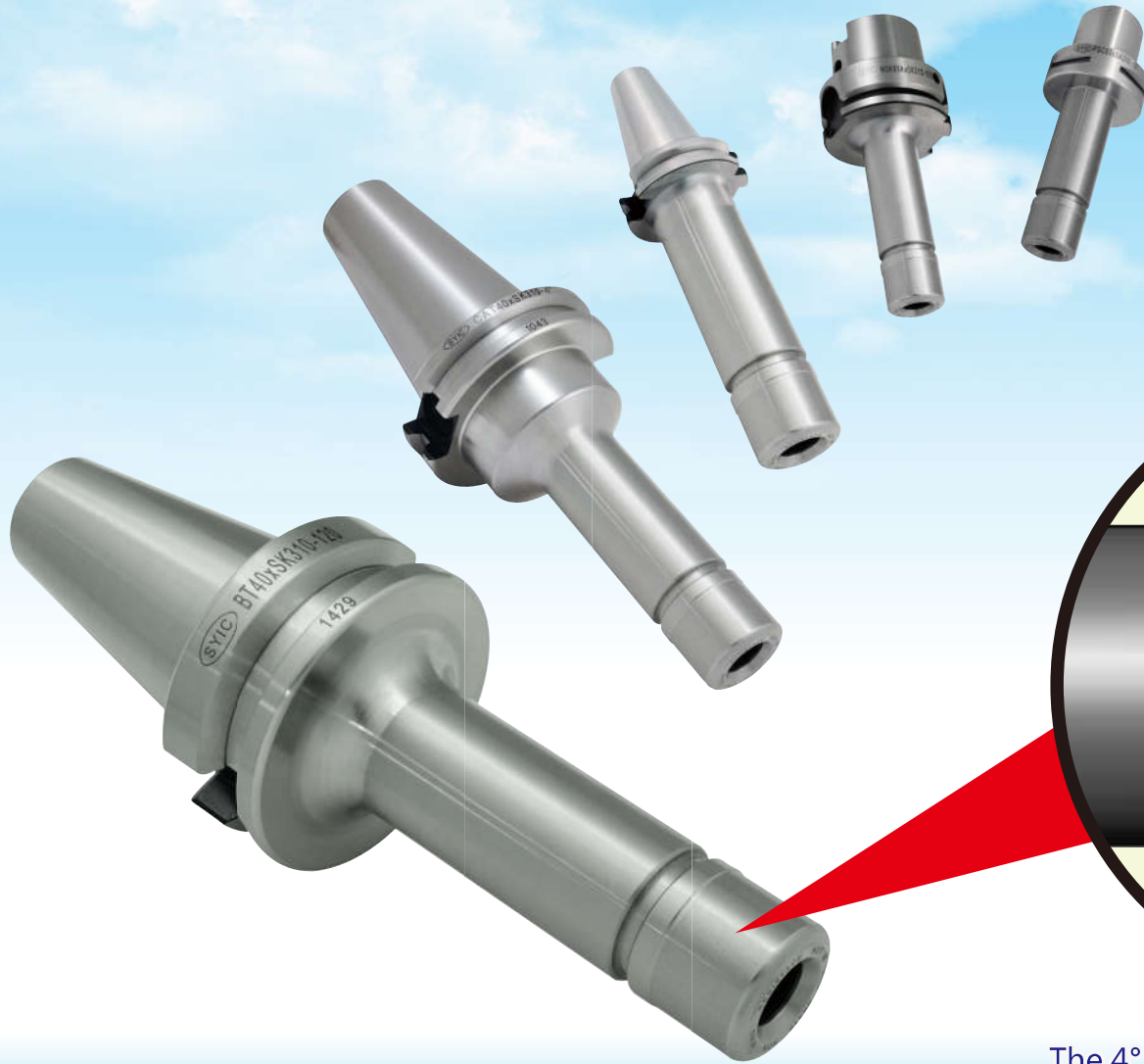

4° slanted design has better stability.

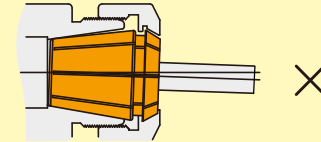

8° slanted design doesn't have enough stability.

The dust-proof design of tool holders prevents metal chips and coolant fluid from going into tool holders.

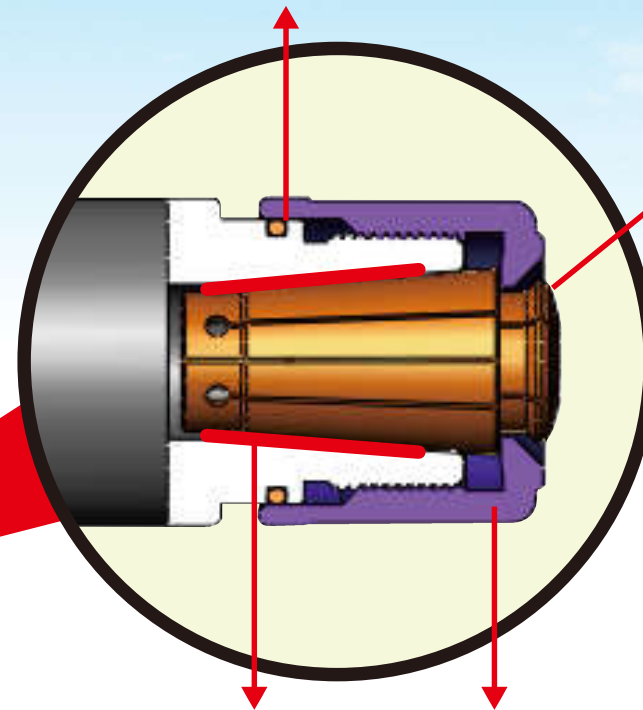

Protruding surface of collet avoids metal chips getting into the collet.

The 4° slanted design increases the clamping power.

SK3 nut is exchangeable with other brands on the market.